

**OPEN EDUCATIONAL
RESOURCES
4
OPEN SCHOOLS**

Taking Education to the People



Open Educational Resources (OER) for Open Schooling

The Commonwealth of Learning (COL) Open Schools Initiative launched an Open Educational Resources (OER) Project to provide materials under the Creative Commons license agreement to support independent study in 17 specially selected secondary school subjects. Funded by the William and Flora Hewlett Foundation its aim is to broaden access to secondary education through the development of high quality Open Distance Learning (ODL) or self-study materials.

These specially selected OER subjects include:

1. Commerce 11
2. Coordinated Science 10 (Biology, Chemistry and Physics)
3. English 12
4. English Second Language 10
5. Entrepreneurship 10
6. Food & Nutrition
7. Geography 10
8. Geography 12
9. Human Social Biology 12
10. Life Science 10
11. Life Skills
12. Mathematics 11
13. Mathematics 12
14. Physical Science 10
15. Physical Science 12
16. Principles of Business
17. Spanish

Open Educational Resources are free to use and increase accessibility to education. These materials are accessible for use in six countries: Botswana, India, Lesotho, Namibia, Seychelles and Trinidad & Tobago. Other interested parties are invited to use the materials, but some contextual adaptation might be needed to maximise their benefits in different countries.

The *OER for Open Schooling Teachers' Guide* has been developed to guide teachers/instructors on how to use the Open Educational Resources (OER) in five of these courses.

1. English
2. Entrepreneurship
3. Geography
4. Life Science
5. Physical Science

The aim of this teachers' guide is to help all teachers/instructors make best use of the OER materials. This guide is generic, but focuses on Namibian examples.

Print-based versions are available on CD-ROM and can be downloaded from www.col.org/CourseMaterials. The CD-ROM contains the module and folders with additional resources, multimedia resources and/or teacher resources. Note that not all subjects have multimedia resources.

Acknowledgements:

The William and Flora Hewlett Foundation
Namibian College of Open Learning (NAMCOL): www.namcol.com.na
National Institute of Educational Development (NIED): www.nied.edu.na
Ministry of Education of the Republic of Namibia (MoE): www.moe.gov.na
Ministry of Education, Seychelles: www.education.gov.sc
Ministry of Education and Training, Lesotho: www.gov.ls/education
Ministry of Education Trinidad & Tobago: www.moe.gov.tt
National Open School of Trinidad & Tobago (NOSTT): www.moe.gov.tt/NOSTT
Ministry of Education and Skills Development, Botswana: www.moe.gov.bw
Botswana College of Distance and Open Learning (BOCODOL): www.bocodol.ac.bw
Ministry of Education Zambia: www.moe.gov.zm

Commonwealth of Learning, 2012

CC BY-SA

© 2012 by the Commonwealth of Learning. Open Educational Resources (OER) for Open Schooling are made available under a Creative Commons Attribution-ShareAlike 3.0 Licence (international): <http://creativecommons.org/licenses/by-sa/3.0>.

For the avoidance of doubt, by applying this license the Commonwealth of Learning does not waive any privileges or immunities from claims that it may be entitled to assert, nor does the Commonwealth of Learning submit itself to the jurisdiction, courts, legal processes or laws of any jurisdiction.

Published by:

Commonwealth of Learning
1055 West Hastings, Suite 1200
Vancouver, British Columbia
Canada V6E 2E9
Telephone: +1 604 775 8200
Fax: +1 604 775 8210
Web: www.col.org
Email: info@col.org

The Commonwealth of Learning (COL) is an intergovernmental organisation created by Commonwealth Heads of Government to encourage the development and sharing of open learning and distance education knowledge, resources and technologies.

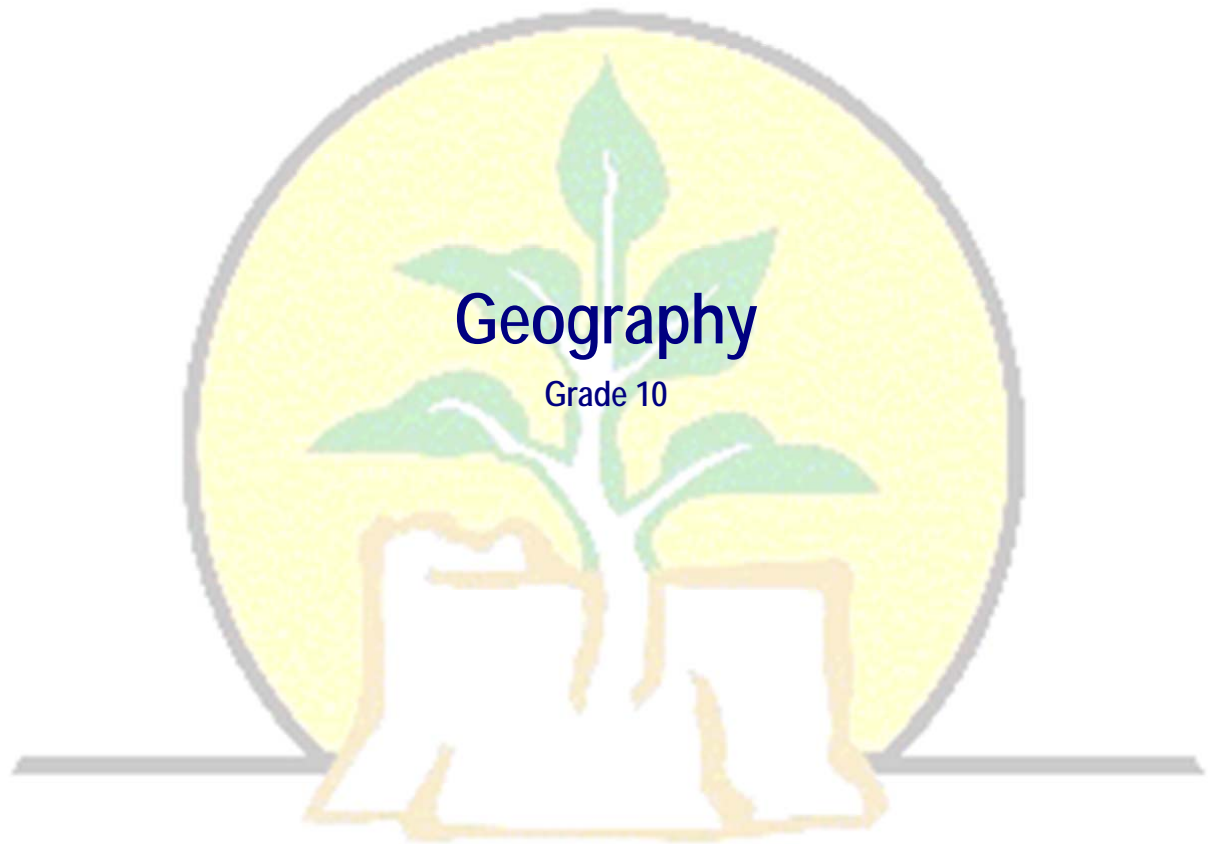

Geography

Grade 10

NAMCOL

Copyright

Copyright: CC-BY-SA (share alike with attribution) Commonwealth of Learning (COL)

<http://creativecommons.org/licenses/by-sa/3.0>

Any part of this document may be reproduced without permission. Attribution to the Commonwealth of Learning, Open Schools Initiative should be included in any derivative works.



NAMCOL

COL Open Schools Initiative

1055 West Hastings St
Suite 1200
Vancouver, V6E 2E9
Canada

Fax: +1 604 775 8210
E-mail: info@col.org
Website: www.col.org

Acknowledgements

The COL Open Schools Initiative/Namibian College of Open Learning wishes to thank those below for their contribution to this Geography Course Material.

Wynand Diergaardt

Writer

Yolande Philander

Writer

Pieter Titus

Writer

Deon Williams

Content Editor

Gerhard de Klerk

Content Editor

Lochna Meeser

Language Editor

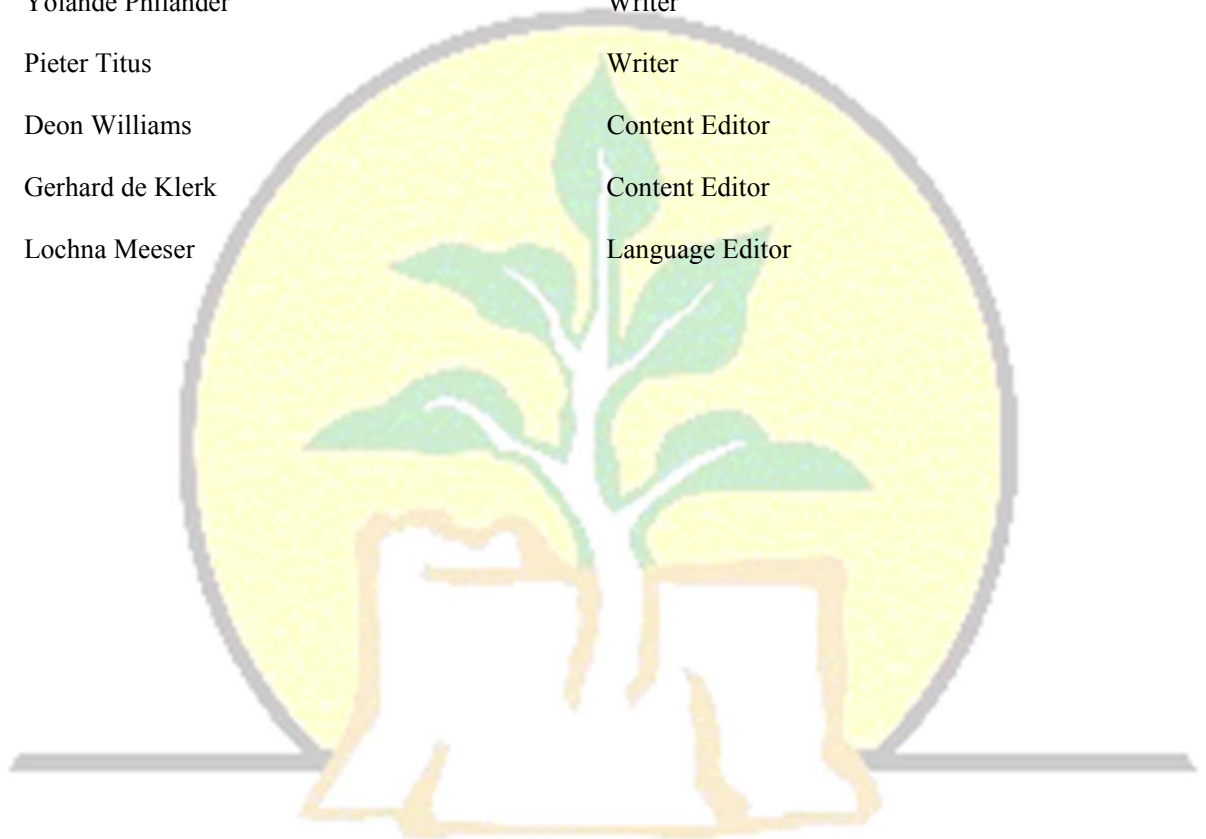

NAMCOL

Contents

About this Geography Study Guide	1
How this Geography is structured	1
Course overview	3
Welcome to Geography Grade 10	3
Geography Grade 10 is this course for you?.....	3
Course outcomes.....	3
Timeframe.....	4
Study skills.....	4
Need help?	5
Assignments Full-Time.....	6
Assignments Part-time	6
Assessments	7
Getting around this Geography Course Material	8
Margin icons	8
Unit 1	9
Mapwork.....	9
Introduction	9
Section 1	10
Interpret maps reflecting human and physical aspects.....	10
What is a map?.....	11
What are maps used for?.....	11
Types of Maps.....	12
Title	14
Date	14
Scale.....	14
Map symbols.....	15
What are symbols and why are they needed?	15
How are symbols constructed?	16
Section 2	20
Measuring and Calculate Distance on Maps with a Variety of Scales	20
Map scales.....	21
Ratio scale.....	21
Linear scale.....	21
Word scale	22
Instructions	22
Conversions.....	23
Measuring distance	26
Calculating distance by using different map scales	27

Section 3	30
Interpret Contour Maps Representing a Variety of Landforms/Height Representation	30
Describe contour maps	30
Contour lines	31
Land forms	32
How are Landforms Made?	32
Landform types and definitions	32
A canyon	33
What is a Canyon Landform?	33
How are Canyons Formed?	33
How it is formed	34
A cliff	34
A desert	35
What Is a Desert Landform?	35
How is a Desert Landform Made?	35
Other Landforms	36
Height Representation	38
Spot heights	38
Trigonometrical beacons	39
Contours	40
Interpolation of spot heights	44
Section 4	47
Map orientation/Determining location in Degrees, Minutes and Seconds	47
What does it mean to orientate a map?	48
How do we do that?	49
Section 5	52
Photographs	52
Why use photographs?	53
Ground level photographs	53
What are ground level photographs?	53
Advantages and disadvantages	54
Recording and interpreting	55
Oblique photographs	56
What are oblique photographs?	56
Advantages and disadvantages	57
Aerial Photographs	59
Advantages and disadvantages	59
Recording and interpreting	60
Section 6	62
Finding direction/map orientation	62
Map orientation	67
What does it mean to orientate a map?	68
Section 7	70
Determining bearings	70
Section 8	73
Draw cross-section and inter-visibility	73

Unit summary	80
Assignment	Error! Bookmark not defined.
Assessment.....	82
References.....	84
Feedback for Assessment.....	85

Unit 2 **87**

Climatology	87
Introduction	87
Section 1	89
Weather: elements, instruments and data	89
Weather Instruments.....	89
A barometer	89
A thermometer.....	91
How a thermometer works.....	91
Calculating average, range and mean temperature	91
Average	91
Range	92
Mean temperature	92
Drawing temperature graphs.....	93
A rain gauge	94
Sunshine recorder.....	94
Anemometer	95
Cup anemometers.....	95
Windmill anemometers	96
Wind vane.....	97
Hygrometer.....	98
Summary of weather instruments	98
Section 2	101
Climatic maps.....	101
Namibia weather map.....	101
Data recording	101
Interpolate by using isolines	101
Difference between	102
Isotherms.....	102
Isohyets	102
Isobars.....	102
Section 3	103
Air pressure systems.....	103
Section 4	109
Synoptic weather maps.....	109
Section 5	112
Micro climates.....	112

References.....	117
Unit summary	118
Assignment	Error! Bookmark not defined.
Assessment.....	120
Assessment Feedback	123
Assignment 1	127
Assignment 1 Feedback	138
Unit 3	144
Ecology	144
Introduction	144
Section 1	146
Deforestation	146
Section 2	155
Desertification	155
Section 3	159
Bush encroachment	159
Bush encroachment in Namibia	159
Solution	160
Section 4	161
Overpopulation	161
Definition.....	161
Effects.....	162
More effects.....	163
Trends of population growth	164
Causes of Overpopulation	165
Solutions.....	166
Section 5	169
Pollution	169
Land pollution	169
How can land pollution be prevented?.....	171
Water pollution.....	173
Enforcing Existing Laws	174
Air pollution	175
Air pollution solutions.....	176
Solutions to Air Pollution	176
Case Study.....	178
Resources	179
Unit summary	180
Assignment	182
Assessment Feedback	184
Assessment.....	Error! Bookmark not defined.
Unit 4	187
Geomorphology	187
Introduction	187

Section 1 Endogenic (internal) forces	188
Landforms Associated with Plate Boundary Activity	191
Fold Mountains	191
Oceanic Trenches.....	192
Island Arcs	192
Ocean Ridges	193
Section 2	194
Fold Mountains.....	194
Fold Mountains	194
Folding.....	198
Section 3 Earthquakes	200
Section 4 Volcanoes	215
Section 5 Exogenic (external) forces.....	228
Unit summary	243
References.....	Error! Bookmark not defined.
Assignment	Error! Bookmark not defined.
Assessment.....	246
Assessment Feedback	247
Assignment 2	248
Assignment 2 Feedback	261

Unit 5	268
---------------	------------

Population Geography	268
Introduction	268
Section 1	270
Population density and distribution	270
What are the factors affecting the distribution of population?	274
Section 2	275
Population Growth	275
Largest populations by country.....	276
Densest populations by country	277
Population Growth	277
Section 3	279
The Demographic Transition Model	279
Section 4.....	283
Population Pyramids.....	283
Types of population pyramid	284
Section 5.....	285
Fertility, Mortality and Migration	285
Section 6	289
Benefits and problems of population growth	289
Section 7	292
The spread and impact of HIV and AIDS	292

References.....	296
Unit summary	297
Assignment	Error! Bookmark not defined.
Assessment.....	297
Assessment Feedback	301
Unit 6	303
Regional Geography of Namibia	303
Introduction	303
Section 1	305
Physical Features and Climate	305
Namibia and neighbouring countries	305
Factors influencing the climate of Namibia.....	308
Section 2	311
Human activities in Namibia.....	311
Section 3	315
Economic growth in Namibia.....	315
Section 4.....	319
Regional unions	319
Unit summary	323
References.....	324
Assignment	Error! Bookmark not defined.
Assessment.....	325
Assessment Feedback	328
Assignment 3	329
Assignment 3 Feedback	341
Sample Question Papers	348
Answers to sample question papers.....	364

About this Geography Study Guide

Geography Grade 10 Study Guide has been produced by COL Open Schools Initiative. All Geography Study Guide materials are produced by COL Open Schools Initiative and are structured in the same way, as outlined below.

How this Geography is structured

The course overview

The course overview gives you a general introduction to the course. Information contained in the course overview will help you determine:

- If the course is suitable for you.
- What you will already need to know.
- What you can expect from the course.
- How much time you will need to invest to complete the course.

The overview also provides guidance on:

- Study skills.
- Where to get help.
- Course assignments and assessments.
- Activity icons.
- Units.

We strongly recommend that you read the overview *carefully* before starting your study.

The course content

The course is broken down into units. Each unit comprises:

- An introduction to the unit content.
- Unit outcomes.
- New terminology.
- Core content of the unit with a variety of learning activities.
- A unit summary.
- Assignments and/or assessments, as applicable.

Resources



For those interested in learning more on this subject, we provide you with a list of additional resources at the end of this Geography these may be books, articles or web sites.

Your comments

After completing Geography we would appreciate it if you would take a few moments to give us your feedback on any aspect of this course. Your feedback might include comments on:

- Course content and structure.
- Course reading materials and resources.
- Course assignments.
- Course assessments.
- Course duration.
- Course support (assigned tutors, technical help, etc.)

Your constructive feedback will help us to improve and enhance this course.

Course overview

Welcome to Geography Grade 10

We sincerely hope that you will enjoy the work and will find it interesting and stimulating. Geography is a very interesting subject. It is a study of the Earth and the interaction between the human race and nature. We, as humans, are totally dependent on the earth. In Geography we are going to study how humans use nature to meet their needs and demands, but we will also look at ways to use the environment in a sustainable way.

Geography Grade 10 is this course for you?

This course is intended for people who want to develop **knowledge with understanding of geography, have an awareness and appreciation about** the relationships and interactions of people and their environment **while acquiring Geographical skills:** Given this background, this study guide requires that you study the guide with the following course outcomes in mind.

Course outcomes



Outcomes

Upon completion of Geography Grade 10 you should be able to:

- *investigate*: ask for, observe, investigate and enquire;
- *interpret*: comprehend, distinguish, interpret, translate data, explain, compare, synthesize and classify;
- *apply* knowledge and skills: measure, locate, produce, identify, build, make, demonstrate, do basic field work, draw sketches, etc.;
- *investigate*: ask for, observe, investigate and enquire;
- *interpret*: comprehend, distinguish, interpret, translate data, explain, compare, synthesize and classify;

- *apply* knowledge and skills: measure, locate, produce, identify, build, make, demonstrate, do basic field work, draw sketches, etc.;
- *communicate*: tell, act out, draw, write, explain, show, display, report and dramatise;



- *value*: show appreciation, evaluate, decide and infer;
- *participate*: take part, participate and present.

Now that you know what is exactly required of you look at the timeframe and all the required and relevant information in this guide.

Timeframe



How long?

1 Year

This is a one year course. The teaching time for this course is 30 weeks. One hour per day times 30 weeks. This is equal to 150 hours for this course. This course consists of 6 units with equal length. Each unit will require 25 hours of study time.

Study skills



As an adult learner your approach to learning will be different to that from your school days: you will choose what you want to study, you will have professional and/or personal motivation for doing so and you will most likely be fitting your study activities around other professional or domestic responsibilities.

Essentially you will be taking control of your learning environment. As a consequence, you will need to consider performance issues related to time management, goal setting, stress management, etc. Perhaps you will also need to reacquaint yourself in areas such as essay planning, coping with exams and using the web as a learning resource.

Your most significant considerations will be *time* and *space* i.e. the time you dedicate to your learning and the environment in which you engage in that learning.

We recommend that you take time now—before starting your self-study—to familiarize yourself with these issues. There are a number of excellent resources on the web. A few suggested links are:

- <http://www.how-to-study.com/>

The “How to study” web site is dedicated to study skills resources. You will find links to study preparation (a list of nine essentials for a good study place), taking notes, strategies for reading text books, using reference sources, test anxiety.

- <http://www.ucc.vt.edu/stdysk/stdyhlp.html>

This is the web site of the Virginia Tech, Division of Student Affairs. You will find links to time scheduling (including a “where does time go?” link), a study skill checklist, basic concentration techniques,

control of the study environment, note taking, how to read essays for analysis, memory skills (“remembering”).

- <http://www.howtostudy.org/resources.php>

Another “How to study” web site with useful links to time management, efficient reading, questioning/listening/observing skills, getting the most out of doing (“hands-on” learning), memory building, tips for staying motivated, developing a learning plan.

The above links are our suggestions to start you on your way. At the time of writing these web links were active. If you want to look for more go to www.google.com and type “self-study basics”, “self-study tips”, “self-study skills” or similar.

Need help?



Help

There is no specific website source for this course. As a student you should utilize web sources addressing issues on your understanding of Geography in different countries. This material is however also available as Open Educational Resource on the Moodle platform.

If you need any academic support, please contact the Tutor for this course. Contact details for this person can be found either in the first tutorial letter for this course or the student Distance Education Manual, which you receive at registration.

For administrative matters, please contact the Distance Education Officer (DEO) for this course. Details of the Geography course can be found in your student Distance Education Manual.



Assignments Full-Time



Assignments

Six practicals and 2 projects.

These practicals and projects are drawn up by the teacher. There are progress exercises after each section of the units for you to complete. Sample answers are also provided for you to compare with your own answers after you have completed the exercises.

Three to five days after it has been given to the learner.

To the subject teacher.

Specific dates will be given to the learner.

The order in which they are set.

Assignments Part-time



Assignments

Three assignments.

Sample assignments are provided after units 2, 4 and 6. You can answer these assignments as practice to see if you have mastered the work.

Specific dates are given.

To the respective tutor if there is contact sessions or submitted to the centre closest to the learner if it is a non-contact learner.

Specific dates.

In the order in which they are set.

Assessments



Assessments

Six tests, two internal examinations and one external national examination. These tests are also set by the teacher. Sample question papers have also been provided for you. You can answer these questions once you have completed the course. Answers to these two papers have also been provided.

Tests and internal examinations are teacher marked, but the external national examination is marked externally.

Tests after each unit has been completed, an internal examination after term 1 and term 2, an external national examination at the end of term 3.

Six tests will be between 20-40 minutes depending on the length of the test, two internal examinations (Two papers will be set – Paper 1 = 120 minutes and Paper 2 = 90 minutes) and one external national examination (Two papers will be set – Paper 1 = 120 minutes and Paper 2 = 90 minutes).

As stipulated by the time.

Between 5 – 7 days.



















Getting around this Geography Course Material

Margin icons

While working through this Course Material you will notice the frequent use of margin icons. These icons serve to “signpost” a particular piece of text, a new task or change in activity; they have been included to help you to find your way around this Course Material

A complete icon set is shown below. We suggest that you familiarize yourself with the icons and their meaning before starting your study.

			
Activity	Assessment	Assignment	Case study
			
Discussion	Group activity	Help	Note it!
			
Outcomes	Reading	Reflection	Study skills
			
Summary	Terminology	Time	Tip

Unit 1

Mapwork

Introduction

Welcome to the first unit of this geography course. The first unit deals with map work and to be able to understand and to master this unit a prerequisite is background knowledge of grade 8 and 9 map work. We will explain how to interpret maps, calculate distance, interpret landforms on maps, orientate maps, draw simple and freehand cross-sections and draw isolines. The teaching and learning process should be as practical as possible. Study the outcomes of the unit first before you work through the content.

Upon completion of this unit you should be able to:



- *interpret* maps reflecting human and physical aspects;
- *calculate* distance on maps with a variety of scales;
- *interpret* contour maps representing a variety of landforms;
- *determine* the location in degrees, minutes and seconds;
- *obtain* geographical information from horizontal and oblique photographs;
- *orientate* any map;
- *draw* simple freehand cross-sections and determine inter-visibility;
- *draw* an isoline on a map to connect places with equal values (*interpolation*).

Now that you have studied the outcomes and know what is expected of you I want you to look at the timeframe first to see how much time is needed to complete this unit.



How long?

You will need approximately 25 hours to complete the unit.

Now that you have familiarise yourself with the time that is required to complete this unit study the following terminologies first.



Terminology

map:	A map is a reduced representation of the surface of the earth or area on a flat sheet with a scale.
inter-visibility:	It is whether you will be able to see from one point to another.
isoline:	Lines connecting places with the same value.
interpolation:	Connecting places with equal value.
cross-section:	An illustration showing what a line scale will look like as seen from the sight.
bearing:	The location of one place from the other in degrees.
physical feature:	These are natural features in the environment.
scale:	The proportion of distance between two points on the ground and between the same two points on a given map.

Section 1

Interpret maps reflecting human and physical aspects

In this section we will look at different ways of interpreting maps. Interpreting means to explain the meaning or significance of something. In interpreting maps we need to look at various ways of finding information on maps. Let's study the section outcomes below first before proceeding to the content.

Upon completion of this section you should be able to:

- *interpret* maps reflecting human and physical aspects



Section outcomes

A student should know how to:

- ▣ *define* a map;
- ▣ *read* a key related to a map by using map symbols;
- ▣ *use* maps;
- ▣ *write* simple sentences about a map;
- ▣ *develop* their map reading skills;

What is a map?

Before you can interpret a map you need to know some facts about maps and map work. You can use the following definition for explaining a map. A map is a picture or representation of the Earth's surface.

Therefore maps:

- show how things are related to each other by distance (both horizontal and vertical), direction, and size.
- are a way of showing many things about a portion of the Earth's real three dimensional surface on a flat piece of paper. This two dimensional representation can be carried and transported easily.
- are not pictures of the Earth's surface.
- can focus on one feature, such as streets or population distribution.
- can show many things that pictures cannot show.

So let's look at what maps are used for.

What are maps used for?

If you take a map you will see that it has many uses. Let's list a few uses of maps.

- Maps are important in the appraisal, conservation, and development of natural resources; in analyzing and forecasting weather conditions; in agriculture, fisheries, and general commerce; in regional planning; and in property surveys and the demarcation of boundaries.
- Maps help in navigation by sea, air, and land in times of peace and especially in times of war.
- Maps are also important to scientists concerned with the causes and effects of Earth surface phenomena, in such disciplines as geology, oceanography, meteorology, climatology, animal and plant ecology, agronomy, economics and the social sciences, as well as geography itself.
- Maps record observations, aid in analysis, stimulate ideas and aid in the formulation of working hypotheses.

When discussing maps you can ask the following questions.

1. Which of the following map elements can you find on the map?
 - ▣ Title, legend, compass, author (mapmaker), scale, date
2. What does the map tell you about the place and time it was created?
3. What is the purpose of this map?



In-text question

If you compare your map to a current map of the same area. What type of information and characteristics does the two have in common and what information are unique to each other.

In most instances, you should start by describing what the map shows and the main area it covers, but only if this is not simply repeating the caption.

Avoid unnecessary detail, but if relevant:

- Describe the scale and list the key items;
- State the orientation and use 'north, east, south and west' not 'up, down, left and right';
- Describe the level of detail shown on the map;
- List the countries or regions shown;
- Describe rivers, road and railways;

Read off the information that is needed, for example, the movement of troops, the differences in rainfall and so on.



In-text question

What different types of maps can be found?

Types of Maps



Type of maps	Description
Political Maps -	A political map is a map that shows lines defining countries, states or territories. It is unlike other maps in that its purpose is to show borders. A political map also makes a deliberate political statement about which areas of the earth belong to a country or state.

Weather Maps -	A weather map displays various meteorological features across a particular area at a particular point in time.
Disaster Maps -	Shows disaster areas such as floods, fires, drought
Road Maps –	Show major—some minor highways—and roads, airports, railroad tracks, cities and other points of interest in an area. People use road maps to plan trips and for driving directions.

Figure 1.1

Now that you have completed the part on maps do the following activity.

Activity 1



Activity

1.1 As a homework assignment, find different types of maps. Newspapers are a good source, or have a look on the Internet. Determine what the maps are used for. Here are examples of the type of maps you may find:



POLITICAL MAPS - locate a country, city, or state

WEATHER MAPS - see how the weather fronts are moving into an area

DISASTER MAPS - locate centres of problem areas

ROAD MAPS - help people locate a business that might be advertising in a newspaper

1.2 Define a map.

Once done with the activity, please compare your answers with mine before you proceed.



How long?

You will need enough time to browse through newspapers. In this activity you need 45 minutes to fully answer the question.



Feedback

1.1 After students bring in the maps, discuss what they have found.

This will help the students see the broad range of uses that maps have in our society.

1.2 A map is a simplified version of the earth and maps:

- *show how things are related to each other by distance (both horizontal and vertical), direction, and size.*
- *are a way of showing many things about a portion of the Earth's real three dimensional surface on a flat piece of paper. This two dimensional representation can be carried and transported easily.*
- *are not pictures of the Earth's surface.*
- *can focus on one feature, such as streets or population distribution.*
- *can show many things that pictures cannot show.*

I hope you have managed to do the activity.

Let's look at important information on a map. To read a map it is important that you familiarize yourself with the following:

Title

Each map has a title with the following information on it e.g. 2217 BA Namibia. The 22 represents the line of latitude and the 17 the line of longitude. BA is the specific map of the B block.

Date

The date on the other hand shows when this map was drawn. Dates are very important seeing that information might be missing and we will only know it if we looked at the date.

Scale

Each map has its own scale and you must know the difference especially if you calculate distance. We will discuss types of scale later.

Let's look at figure 1.2 which shows the title, date and scale on a map. Once you have looked at the map you can study all the important map symbols. It is important to note that there are other symbols that appear can appear on maps, but for now we will concentrate only on the ones that are listed.

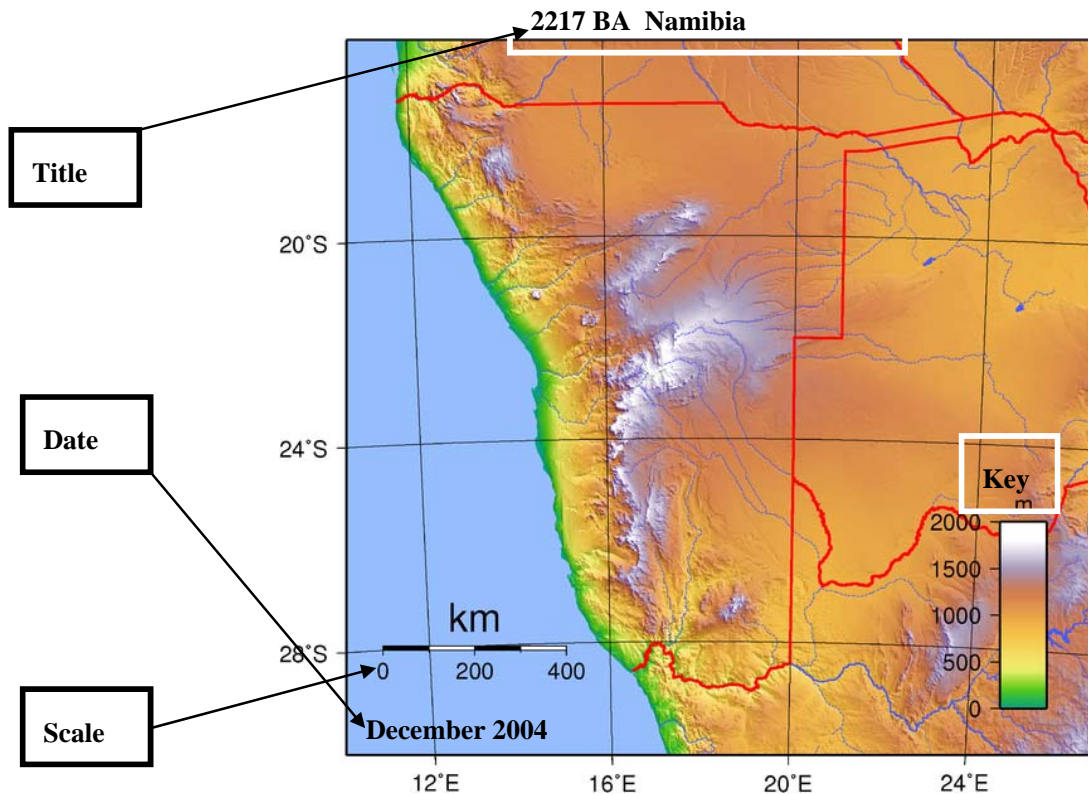

Figure1. 2

Map symbols

To read a map properly it is important that you know the different map symbols. These symbols appear on the map and represent certain features in reality.

What are symbols and why are they needed?

Have you ever wondered what are symbols and why are they needed. Let's answer that question by saying that symbols are simple signs that are used to represent something else. Now seeing that maps require large amounts of information to be conveyed in a limited space, the use of symbols to represent particular features is therefore necessary. These symbols are small but are immediately recognisable, which means that they have an advantage over drawing or writing all of this information onto a map.

Map symbols can be divided into three groups: **point, line** and **area symbols**. Let's look at them separately:

- Point symbols are often used to represent a specific place or site. These point symbols are usually made of basic shapes, since they can be immediately recognised even when they have been reduced in size.

- Line symbols are used to represent linear features, including roads, rivers and borders. A variation of these line symbols are created by making lines coloured, widened, bold, multiple and interrupted (dotted).
- Area symbols use colour, patterns and symbols to show the characteristics of a region. These symbols show features such as deserts, forests or crops.



In-text question















How do you think are these symbols constructed?













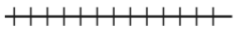



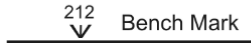

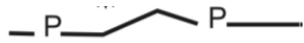
How are symbols constructed?

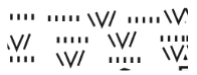
The explanation is clear and easy because there is no universal system that requires particular map symbols to represent certain features in the real world. When you look at the system of symbols that are used in two different maps it is, however, often noticed that there are some similarities between symbols for common features including hospitals, post offices and railway lines. Symbols are most effective when they can be logically associated with a specific feature in the real world; cartographers (people who create maps) always try to draw symbols which resemble the feature that they are representing. This is often why camping grounds are depicted by a simple triangular-shaped tent and picnic spots are conveyed by a picnic table and chairs.

To read a map properly it is important that you know the different map symbols. These symbols appear on the map and represent certain features in reality. Figure 1.3 below gives us some examples of map symbols.

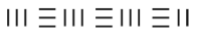
Map symbols

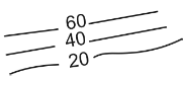
International Boundaries 	Huts 
Provincial boundaries 	Monuments 
Multiple track railways 	Dipping tanks 
Single track railways 	Walls 
Electrified railways 	Windmills 
Narrow gauge railways 	Anti-erosion walls 
	Excavations 
	Perennial water 

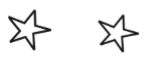
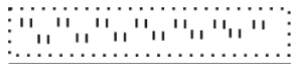
	
Service railways 	Non-perennial water 
Trunk roads 	Dry pans 
Main roads  212 Bench Mark	Springs, boreholes, waterholes, wells • F
Secondary roads 	Pipelines 
Other roads 	Marshes and swamps 
Tracks and footpaths 	Photo centres 
Power lines 	Prominent rocky outcrops 
Telephone lines 	Contour lines 
Post offices, police stations, stores, hotels ■ P ■ PS ■ W ■ H	Spot height • 251.4
Schools and places of Worship ■ S ■ K	Terraces 
Lighthouses and marine lights 	Cultivated lands 
Marine beacons	Orchards and vineyards





	
<p>Trigonometric beacons</p> <p>beacon number on right $\triangle 47$</p> <p>height below 304.6</p>	<p>Trees and bush</p> 
<p>Magnetic stations and ground</p> <p>Signs</p> 	<p>Grasslands</p> 

Figure 1.3 (Should be replaced, only example from NAMCOL JSC Geography book)

The following activity is designed to help you assess your understanding of maps and map symbols. Let's do the next activity.

Activity 2

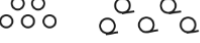

Activity



How long?

Practice your knowledge on map work by studying the map and then answer all the questions.

Time Required: In this activity you need 30 minutes to answer the question.

Study the map and answer the following questions.

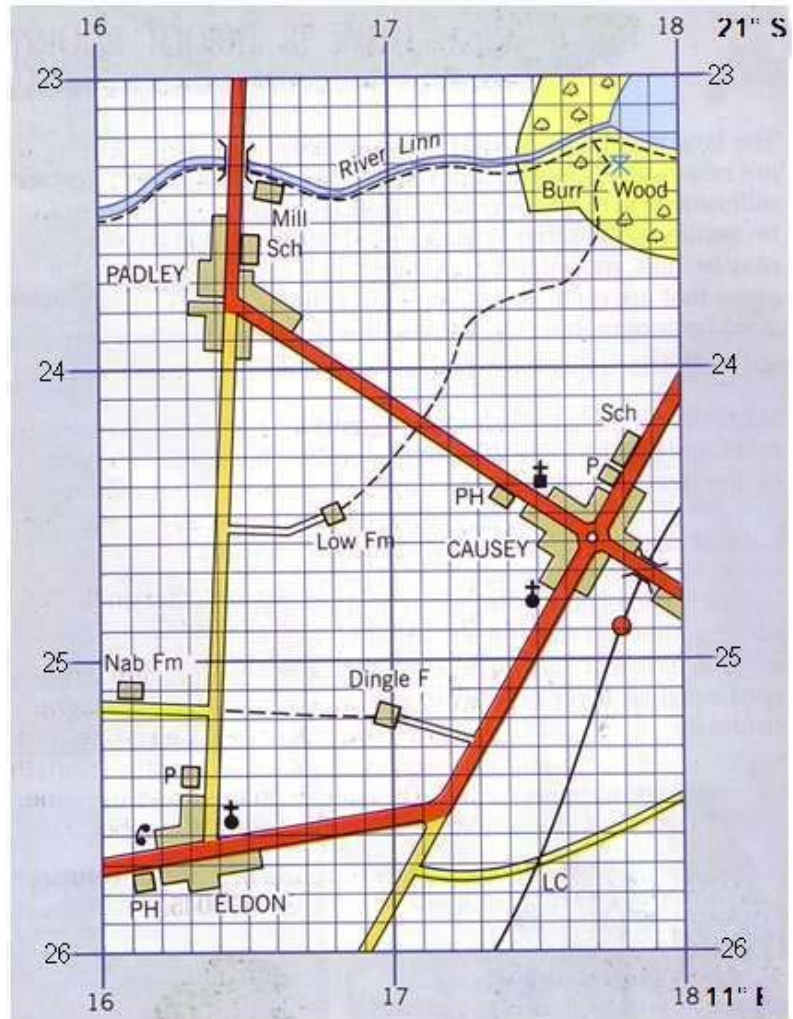

Source: <http://www.teachnet.uk.org.uk>

2.1 Identify six man made features on the map. Draw a table with two columns and six rows in your exercise book. Draw the feature and give the meaning next to it e.g.

Feature	Description
✕ ┆	Windmill





2.2 Give the exact location of these features in degrees, minutes and seconds, except the footpath.

Once done with the activity, please compare your answers with mine before you proceed.

2.1.

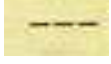

Feedback

Feature	Description
	Church
	Telephone
	Picnic site
	Bridge
	Station
	Path

2.2 Church	21°24'24" S; 11°17'30" E
Telephone	21°25'36" S; 11°16'6" E
Picnic site	21°23'18" S; 11°17'48" E
Bridge	21°23'18" S; 11°16'30" E
Station	21°24'54" S; 11°17'48" E

I hope you have managed to do the activity.

Let's proceed and look at section 2 which deals with calculating distance.

Section 2

Measuring and Calculate Distance on Maps with a Variety of Scales

To calculate distance is very important in geography seeing that everyone constantly wants to know the distance from one place to another. Now look at the section outcomes of this unit before we discuss distance calculating.

Upon completion of this section you should be able to:



Section outcomes

- *calculate* distance on maps with a variety of scales;
- *measure* straight line and curve distances.

Map scales

It is important for you to know that the scale of the map is determined by the amount of real-world area covered by the map. Almost all maps have scales. Scales play an important role in maintaining the dimensional accuracy of a map.

The following types of scales are used:

Ratio scale

1:24 000

This type of scale is known as a ratio scale and what it means is that one centimetre (cm) on a map is equal to 24,000 cm (or 2 km) in the real world. Actually, it means that one of anything [mm, cm, etc.] on the map is equal to 24,000 of the same thing on the map. Another way of writing this would be a fractional scale of $1/24,000$, meaning that objects on the map have been reduced to $1/24,000$ th of their original size. Very interesting.

Other map scales in common use for topographic maps are 1:25 000, 1: 50 000 and 1: 250 000.

Did you know that the smaller the ratio is between distances on the map and distances in the real world, the smaller the scale of the map is said to be.



Tip

This actually means that, a map with a scale of 1:250 000 is a smaller scale map than a 1:25 000 scale map, but it covers a larger real-world area.

Linear scale

A linear scale comes from the word line, which actually means that the scale is in a horizontal line form. Scales are frequently featured in map legends (tables explaining the meaning of symbols, signs colours and abbreviations used on a map). We can therefore say that a linear scale is a line which is divided into sections. It shows how measurements on a particular map correspond with measurements on the ground. Now look at an example of a linear scale in figure 1.4.

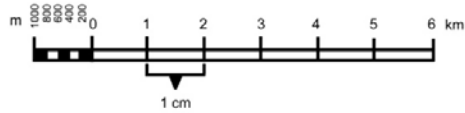

Figure 1.4

Word scale

Word scale means a description of the scale in words. One centimetre on the map represents one kilometre in reality.

Word scale



Each map has a different scale.

Figure 1.5

http://www.ehow.com/how_6193164_calculate-distance-using-map-scale.html

Maps show the layout of an area in a condensed format for the convenience of the user. Even if the map represents just of a small neighborhood, every part of the neighbourhood must be scaled down to fit on a single sheet of paper. The map scale lets you know by how much the distances have been scaled down so you can calculate the real-world distance between different points on the map. To do this, you need to know the distance on the map and the scale factor.

The relative distance between two points on a map is the same as the relative distance between two points in the real world. Maps show the scale to which they are drawn, such as "one cm equals five km." You can use a map's scale to calculate both straight-line map distances and map driving distances.

Use the following instructions to measure the distance on the map and then convert the distance to the real distance in reality.

Instructions

1. Find and note the scale information on your map. Scale information is usually located at the edge of a map or in the border around a map so that it is easy to find. Locate two points on the map between which you want to calculate the distance. For illustration, the two points will be called A and B.

Remember, there are
1000 metres in 1
kilometre

2. Use a ruler to measure straight-line map distances. Place the zero mark on the ruler at point A and the edge of the ruler with inch measurements at point B, and note the distance between them. For example, point A might be 3 cm from point B.
3. Convert the distance in cm to distance in km using the map's scale information. For example, if your ruler shows 3 cm from point A to point B, and your map scale shows that 1 cm equals 5 km, the straight-line map distance equals 3 times 5 km, or 15 km.
4. Use a string to measure map driving distances. Place one end of the string at point A on the map. From that point, lay the string along the route you intend to drive, and mark the string where the route ends at point B. Straighten the string and use your ruler to measure the length in cm from the end of the string you placed at point A to the mark you made at point B.
5. Convert the distance in cm to distance in km as before. For example, if the string is 3,5 cm from point A to point B, and your map's scale shows that 1 cm equals 5 km, the map driving distance equals 3,5 times 5 km, or 17,5 km.

Now the question remains, do you know how to do conversions. Next we will look at some examples on how to do conversions.

Conversions

Sometimes geographers and you need to know how far places are from each other. Instead of going out into the field and measure this distance, which could take some time and may require specialist equipment, geographers can use a scaled map of the area. They simply use a ruler and refer to the provided scale, a person can measure the distance on a map and calculate what it converts to in the real world.

Now let's say the distance between two points on a map is 6.5 centimetres and the scale of that map is 1 centimetre to 10 000 centimetres (also 1:10 000 or 1/10 000), then in the real world the measured distance would represent 65 000 centimetres (or 650 metres). This is something you already know, but let's look at some examples to explain how conversions work.

Example 1.

You measured the distance on the map which is 6.5 centimetres and the scale of the map is 1:10 000. This actually means that the 1 cm of the map represents 10 000 centimetres in reality. We can therefore say: 1 centimetre to 10 000 centimetres. Our further calculation would be that $6.5 \times 10\,000 \text{ cm} = 65\,000 \text{ centimetres}$.

Now, simplify answer this in metres.



Tip

Remember, there are 100 centimetres in 1 metre.

You will therefore simply do the following:

$$65\ 000 \div 100 = 650 \text{ metres}$$



Note it!

It must be remembered that when making conversions, scales are not always in the same units. Sometimes, maps feature scales which are 1 centimetre to 1000 metres (also 1:1000 or 1/1000). In this case, 6.5 centimetres on the map would represent 6500 metres (or 6.5 kilometres) on the ground.

Example 2.

The distance that we have measured is 6.5 centimetres on a map which has a scale of 1 centimetre to 1000 metres. That simply means that:

$$6.5 \times 1000 = 6500 \text{ metres}$$

Now, to simplify that or to convert it to kilometre you can simply do the following:

$$6500 \div 1000 = 6.5 \text{ kilometres}$$

How did we get to that answer? As illustrated above 6500 divided by 1000 is equal to 6.5 kilometres.



In-text question

How are the other scales used to convert the distance measured on a map?

The table below will help you when you do conversion.

Conversion table

Relationships	Conversion rules
1 km = 1 000 000 mm	From mm to km we divide by 1 000 000
1 km = 1 00 000 cm	From cm to km we divide by 100 000
1 km = 1 000 m	From m to km we divide by 1 000
1 m = 1 000 mm	From mm to m we divide by 1 000
1m = 100 cm	From cm to m we divide by 100

Table 1

The following activity is designed to help you assess your understanding of scales and how to do conversions. Write your answer in the space provided below.

Moreover, at the end of activity is the suggested answer. I urge you not to refer the provided answer before you try the question yourself. This is very important in your preparation for the assignments and examination.



Activity



How long?

Activity 3

Work out each of these answers and tick the correct answer for questions 1 – 4. Write the answers for questions 5 – 7 in the spaces provided.

This activity will take you 20 minutes to complete.

- | | True | False |
|--|--------------------------|--------------------------|
| 1. A map has a scale of 1 cm = 5 km.
So 4 cm = 20 km | <input type="checkbox"/> | <input type="checkbox"/> |
| 2. On a map with a scale of 1 cm = 8 miles, 4 cm represents 2 miles. | <input type="checkbox"/> | <input type="checkbox"/> |
| 3. The distance between two towns is measured as 12 cm. The map uses a scale of 1 cm to 4 km, so the towns are 3 km apart. | <input type="checkbox"/> | <input type="checkbox"/> |
| 4. A map uses a scale of 1 cm to 8 km and the distance between two towns on the map is 5 cm. This represents 40 km. | <input type="checkbox"/> | <input type="checkbox"/> |

Use the map below to answer the questions. (Scale 1 cm = 8 km)

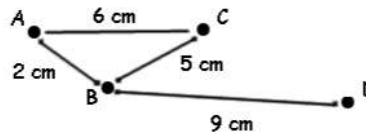

- The distance between A and C is _____ km.
- The journey A to B to C is _____ km.
- Travelling from A to C, then to B and on to D is a total of _____ km.

Source:

<http://www.bbc.co.uk/skillswise/numbers/measuring/distance/worksheet1.shtml>



Feedback

1. True
2. False
3. False
4. True
5. Distance between A and C is 6 cm. 1 cm = 8 km. So $6 \text{ cm} = 6 \times 8 = 48 \text{ km}$.
6. The journey A to B + B to C = 7 cm. 1 cm = 8 km. So $7 \text{ cm} \times 8 = 56 \text{ km}$.
7. Travelling from A to C is 6 cm. From C to B is 5 cm and from B to D is 9 cm. Add up and the total journey is 20 cm. 1 cm = 8 km so $20 \times 8 = 160 \text{ km}$.

I hope you managed to do the activity. Next we will look at measuring distance.

Measuring distance

On a map, distances can be measured in two ways: along a straight line or along a curved line.

1 Along a straight line

To measure a straight line, simply use your ruler. For example, the distance from A to B shown here is 5.6 cm.

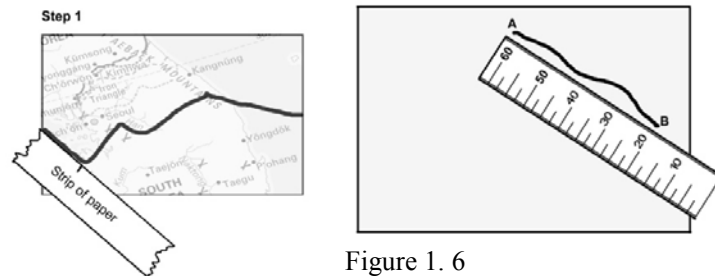

Figure 1. 6



2 Along a curved line

To measure a curved line you need a piece of paper with a straight edge.

Step 1: Put the paper strip with the straight edge on the first straight part of the road or curved line. Mark point B onto the strip at the beginning of it and make another mark (b) where the road starts to curve away from the paper strip.

Step 2: Keeping the mark of (b) firmly fixed, rotate the straight edge of the paper strip until it follows the next straight part of the road.

Now mark (c) where the road curves away again (up or down) from the paper strip.

Step 3: Keep on rotating the paper strip and marking the parts on the strip, until the whole curved distance, from A to B, is marked onto the strip of paper.

Step 4: Lay the paper strip against your ruler and read the distance from A to B as done below.

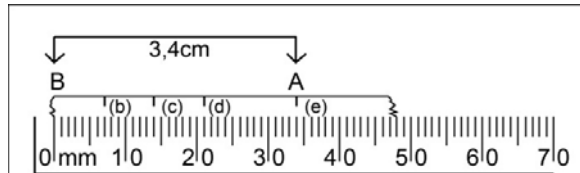

Figure 1. 7

Work out the real distance by using the map scales provided.

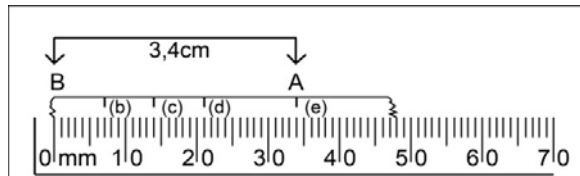

Figure 1. 8

Calculating distance by using different map scales

If you know how to use map scales, you can easily work out the real distance between places.

Africa

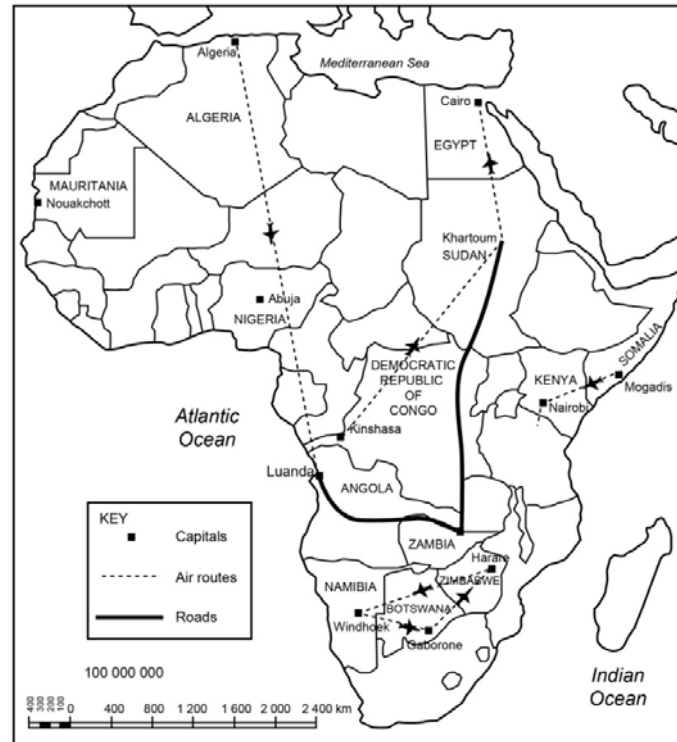

Figure 1.9

Figure 1.9 is provided with a ratio and a linear scale.

To use the ratio scale, you must understand the following formula:

Ratio scale = (if you convert from cm to km)

Let us measure the distance the aeroplane travelled between Mogadishu in Somalia and Nairobi in Kenya by using our formula.

$$\begin{aligned} \text{Map distance} &= 1.5 \text{ cm} \times \text{map scale} \\ &= 1.5 \text{ cm} \times 60\,000\,000 \text{ cm} \\ &= 90\,000\,000 \text{ cm} \div 100\,000 \text{ (to convert to km)} \\ &= 900 \text{ km} \end{aligned}$$

To use the linear scale, you must understand how to read the distance on this type of scale. It allows you to measure the real distance between places on a map.

Use your ruler and measure the map distance from Windhoek to Luanda on the map of Africa (Figure 1.9). The distance is 2.7 cm. Now place your ruler on the linear scale so that the 2.7 cm mark on the ruler is directly below the 1 200 km mark on the linear scale (between 2 cm and 3 cm). Now study Figure 1.6. Point

A is Windhoek and B is Luanda. Point A lies somewhere in the secondary units on the left side of the 0 (zero). Take the reading from 0 on the linear scale to point B. Do the same from 0 on the linear scale to point A and add the two readings (distances). The answer will give you the distance in km (kilometres) between Windhoek and Luanda.

To convert
from mm to
km, you will
divide by 1000.

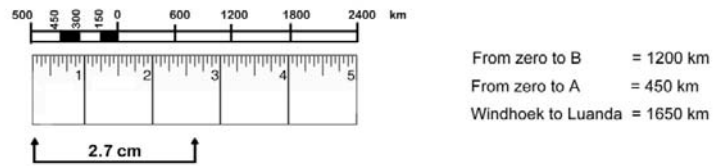

Figure 1.10

Let's pause for a while and do activity 4.

Activity 4



Activity



How long?

Time Required: In this activity you need at most 45 minutes to fully answer the question.

Look at the map of Namibia and calculate the distances.



1. Calculate the distance from Cimbebasia (B1) along the road to Otjomuise (C28). Give the answer in kilometres. Use the scale provided on the map.
2. Measure the distance as the crow flies from Daan Viljoen Game Reserve to Avis Dam.

Once done with the activity, please compare your answers with mine before you proceed.



Feedback

- 1.
- 2.

I hope you are clear on the different types of scales and how to calculate distance. In the next section we will look at contour map interpretation.

Section 3

Interpret Contour Maps Representing a Variety of Landforms/Height Representation

It is an important skill to be able to identify features on a map. Many people use these mapping skills in their daily lives. This section explains how to interpret topographic maps, as well as how to locate features on a street map. Now look at the section outcome of this section before we discuss these aspects.

Upon completion of this section you should be able to:



Section outcomes

- interpret contour maps representing a variety of landforms;
- *use* spot heights to find height above sea-level;
- *use* trigonometrical beacons/trig. Stations to find height above sea-level;
- *use* contour lines to find height above sea-level;
- *interpret* contour maps representing a variety of landforms;
- *use* spot heights to draw simple contour maps.

Describe contour maps

A topographic map is a type of map characterized by large-scale detail and quantitative representation of relief, usually using contour lines in modern mapping, but historically using a variety of methods. Traditional definitions require a topographic map to show both natural and man-made features. A topographic map is typically published as a map series, made up of two or more map sheets that combine to form the whole map.

A topographic map is a detailed and accurate graphic representation of cultural and natural features on the ground.

In practice we normally think of two types of map:

- topographic map - a reference tool, showing the outlines of selected natural and man-made features of the Earth
 - ▣ often acts as a frame for other information
 - ▣ "Topography" refers to the shape of the surface, represented by contours and/or shading, but topographic maps also show roads and other prominent features
- thematic map - a tool to communicate geographical concepts such as the distribution of population densities, climate, movement of goods, land use etc.

In this section, however, we will only discuss the topographic features.



In-text question

An understanding of concepts like contour lines is important. Do you know what contour lines are?

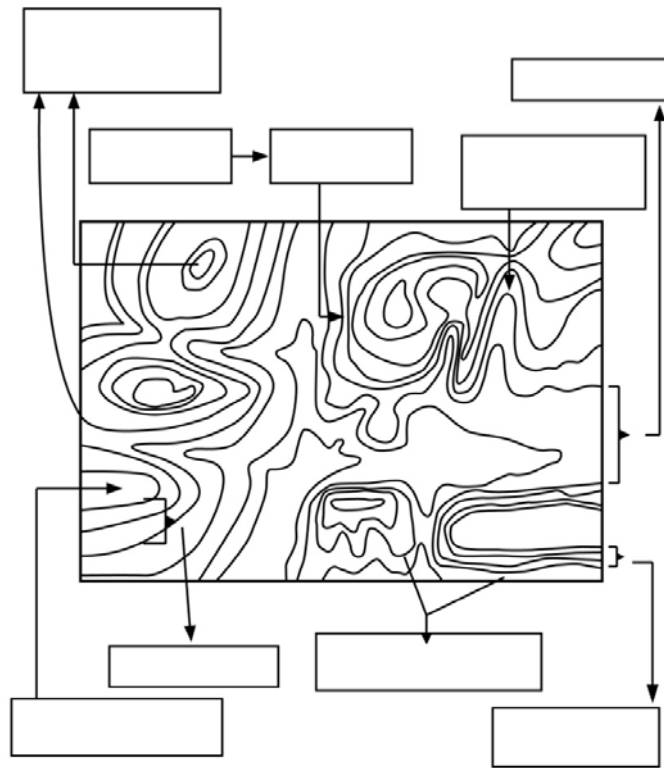

Figure 1.11 (replace)

Contour lines

Contour lines are lines drawn on a map connecting points of equal elevation. If you walk along a contour line you neither gain nor lose elevation.

If you walk along a beach exactly where the water meets the land the following are important. The water surface marks an elevation we call sea level, or zero. As you walk along the shore your elevation will remain the same, which means you will be following a contour line. If you start walking into the ocean, the height of the ground (in this case the seafloor) is below sea level. If you walk into the other direction up the beach your height will be above sea level (see figure 1. 12).

Contour Line Explanation

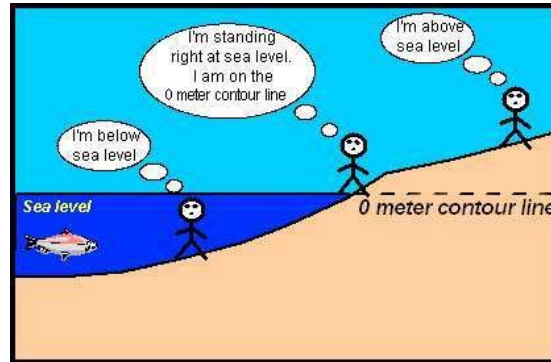

Topography

The features of the surface of an area of land.

Figure 1.12

Source:<http://raider.mountainunion.edu/~mcnaugma/Topographic%20Maps/contour.htm>

The contour line represented by the shoreline separates areas that have heights above sea level from those that have heights below sea level. We refer to contour lines in terms of their height above or below sea level. In this example the shoreline (beach) would be the zero contour line (it would be 0 meters). Contour lines are therefore very useful because they allow us to show the shape of the land surface (**topography**) on a map.

Land forms

A landform or physical feature in the earth sciences is defined by its surface form and location in the landscape, as part of the terrain, and as such, is typically an element of topography. Landform elements include spurs, valleys, hills, cliffs, canyons, waterfalls, deserts etc.

How are Landforms Made?

- Some **landforms** are created by the action of wind, water, and ice. This action physically changes the Earth's surface by carving and eroding land surfaces, carrying and depositing soil, sand and other debris.
- Crustal movement and other tectonic activity inside Earth create landforms; mountains, faults, sinks, and volcanoes.

Landform types and definitions

- Altitude (elevation)
the height above sea level

- Archipelago
a group of many islands

A canyon

1. Narrow valley
2. Steep sides
3. Created by erosion

Canyon Landforms Examples:

Grand Canyon in Arizona

Bronson Canyon Los Angeles, California

What is a Canyon Landform?

When we think of a canyon landform, the first type of canyon we probably think of is the Fish River Canyon located in Southern part of Namibia. It is one of the most scenic and popular types of canyons people visit in Namibia. People look at this type of landform as two steep cliffs with a valley that runs through it. The Fish River Canyon has the Fish River running through it.

How are Canyons Formed?

A canyon has to be formed through erosion. There are a couple of ways this erosion occurs. The most common way is look at the Fish River. The Fish River carved out the great Fish River Canyon by taking the land down the river with it. What was left was a river valley with steep cliffs. This process took thousands of years.

Another way these great landforms can be formed is through wind and glaciers. This is not too common but does happen. The **Fish River Canyon** is located in the south of Namibia. It is the second largest canyon in the world and the largest in Africa, as well as the second most visited tourist attraction in Namibia. It features a gigantic ravine, in total about 160 km long, up to 27 km wide and in places almost 550 metres deep.

Namibia – Fish River Canyon



Figure 1.13

Source: http://en.wikipedia.org/wiki/Fish_River_Canyon

The Fish River is the longest interior river in Namibia. It cuts deep into the plateau which is today dry, stony and sparsely covered with hardy

drought-resistant plants. The river flows intermittently, usually flooding in late summer; the rest of the year it becomes a chain of long narrow pools. At the lower end of the Fish River Canyon, the hot springs resort of Ai-Ais is situated.

Another example in Namibia is the Sesriem Canyon - Sesriem is also known for the **Sesriem Canyon**, about 4 km from Sesriem itself, which is the second most important tourist attraction in the area after Sossusvlei. It is a natural canyon carved by the Tsauchab rivier in the local sedimentary rock, about a kilometre long and up to 30-meter deep in sedimentary rock. The name *Sesriem* is Afrikaans and means "six belts", given by settlers returning from the Dorsland Trek who had to attach together six belts (made of oryx hides), in order to reach buckets down into the canyon to scoop up water. The Sesriem Canyon is only two meters wide in some places, and has a portion that permanently contains water, which many animals use.

Sesriem Canyon



Figure 1.14

Source: <http://en.wikipedia.org/wiki/Sesriem>

How it is formed

Upstream the river runs through horizontal dolomite strata. These strata formed part of the canyon about 650 million years ago when plate movement cracked the earth, the first process in the formation of the Fish River Canyon.

Lower down, a granite complex system is exposed to form a characteristic river bed that results in forms like Fingerspitze. In this area, a fault runs north-south, which accounts for the gorge-like channel and the presence of hot sulphurous springs.

A cliff

1. High and steep slope;
2. Made of rock or soil

Cliff Examples



Figure 1.15 Source:

A desert

The **Namib Desert** is a desert in Namibia and southwest Angola that forms part of the Namib-Naukluft National Park, the largest game reserve in Africa. The name "Namib" is of Nama origin and means "vast place". Having endured arid or semi-arid conditions for at least 55 million years, it is considered to be the oldest desert in the world.

Namib Desert



Figure 1.16

1. Super-dry air
2. Little rain – less than 10 inches a year
3. High daytime temperatures
4. Lots of wind

Desert Landform Examples:

Namib Desert, The Sahara Desert, Great Basin Desert

What Is a Desert Landform?

A **desert landform** is a place that gets little to no rain. The climate can be either hot or cold and sometimes both. Each desert landform has one thing in common; it has less than 10 mm of rain per year. Usually deserts have a lot of wind because they are flat and have no vegetation to block out the wind.

How is a Desert Landform Made?

The first thing about any desert is it needs to be on land. The second part is it gets little rain or snow throughout the year. It needs to get 10 mm or less a year. With little rain, vegetation is very little, causing dust and sand to blow around because there is nothing to hold it in place. Year without rain or snow causes a dry landform that we call a desert. The definition of

a desert is a region so arid because of little rainfall or snowfall that it supports only sparse and widely spaced vegetation or no vegetation at all.

Other Landforms

We also find other landforms and to be able to identify them I want you to study them separately.

- Hill
a raised part of the earth's surface with sloping sides; old mountain which because of erosion has become rounder and shorter
- Spur

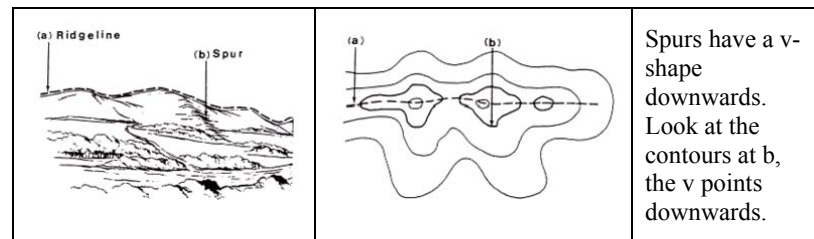

Figure 1.17

- Valley

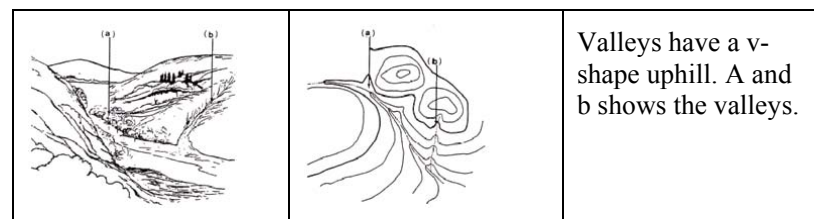

Figure 1.18

- Butte

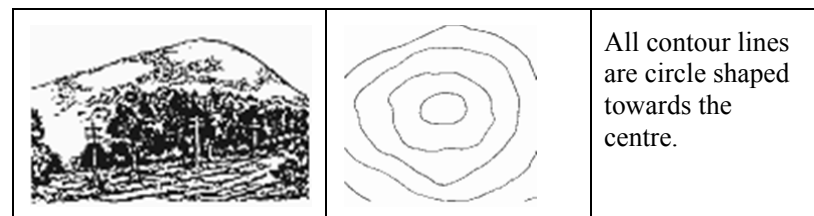

Figure 1.19

- Saddle

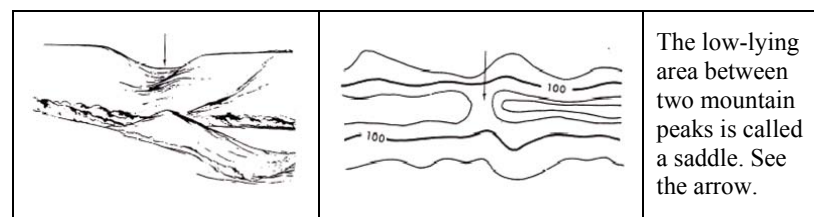

Figure 1.20

Time for another activity to test your knowledge.

Activity 5

Time Required: In this activity you need at most 45 minutes to fully answer the question.



Activity



How long?

1. Identify the slopes AA, BB and C on the map.
- 2) What is the contour interval on the map?
How do you know?
- 3) Write down the highest contour value.
- 4) Write short definitions for contour interval/vertical interval and contour lines.

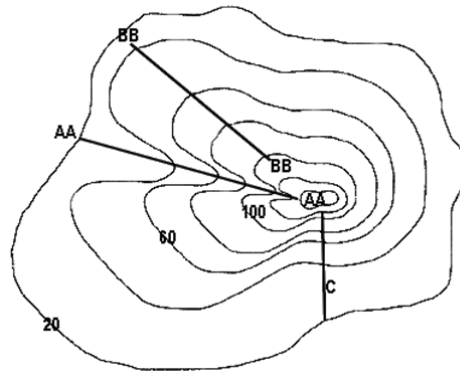

Once done with the activity, please compare your answers with mine before you proceed.



Feedback

1. AA- Valley

BB- Spur

C - Concave slope

2. 20 m

3. 140 m

4. The height difference between contour lines is called contour interval/vertical interval.

Contour lines are on a map that shows height. A line on a map or chart connecting points of equal height.

I hope you have managed to do the activity. Let's proceed and look at height representation.



Height Representation

Do you know how height is represented on a map? You have probably been introduced to the concept in the previous grades, but nevertheless in this section we will explain it to you again.

Three different ways are used to show the height above sea level on a map:

Insert picture of students in a group. A map is spread open on the desk. The following points on the map are enlarged / highlighted: a spot height, a trig beacon and a few contour lines.

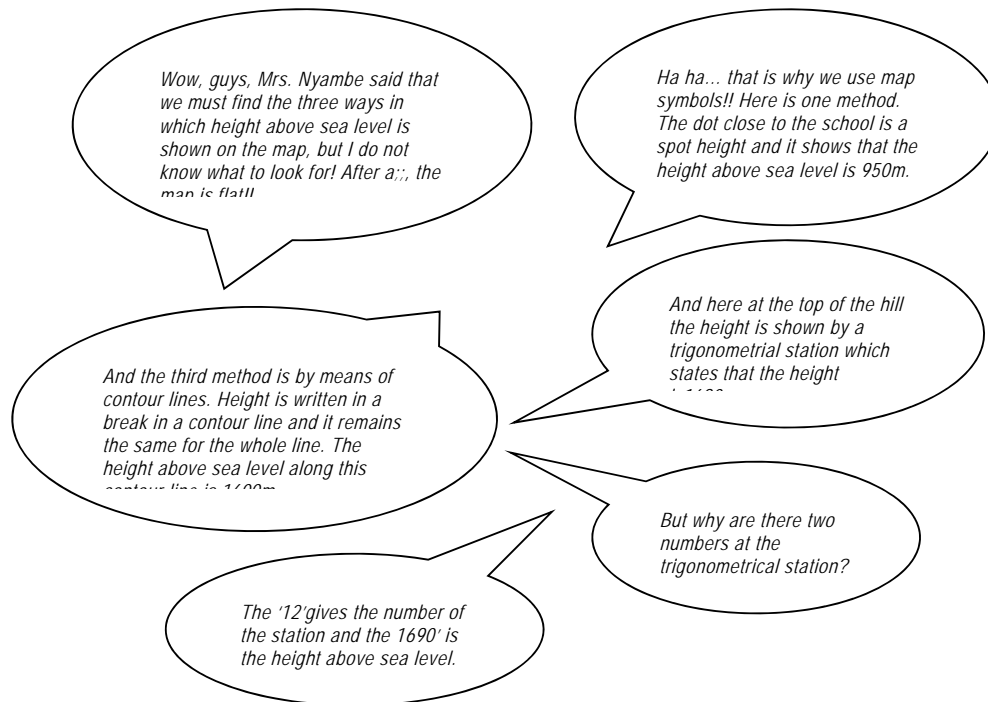

Let us now look in more detail at spot heights, trigonometrical stations and contour lines.

Spot heights

Spot heights are shown by small black dots on the map. Usually they are scattered randomly across a map and some spot heights will have a number next to it. This number indicates the height above sea-level.

Example:

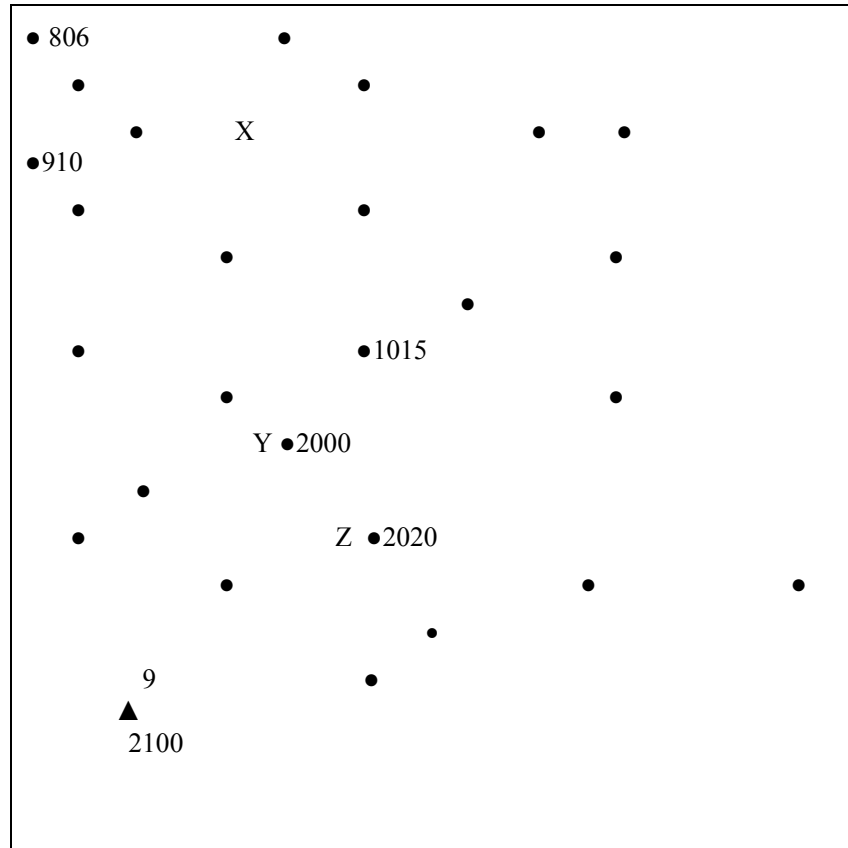

Figure 1.21

It means that the height above sea-level at X is 910m

What is the height above sea-level at Y and Z?

Trigonometrical beacons

Trigonometrical beacons or stations (also referred to as 'trig.' stations) are shown by a small triangle. The number above the triangle indicates the number of the trig. station, while the number below the trig. station indicates the height above sea-level. The highest point on a map is usually shown by a trig. beacon.

For example: 12 → number of trig. station



1835 → height above sea-level

Figure 1.22

Can you give the height above sea level shown by trig. station 12 in Fig. 1. 22?



Contours

Height above sea level on maps can also be shown by contour lines. Contour lines are formed when spot heights with the same value are linked with each other by a line.



In-text question

Can you give a sort definition of spot heights and trigonometrical beacons to your friend?

Let's do the next activity which deals with spot heights and trigonometrical beacons.

Activity 6

Time Required: In this activity you need at most 45 minutes to fully answer the question.



Activity



How long?

Once done with the activity, please compare your answers with mine before you proceed.



Feedback

You have been introduced to contour lines, but seeing that they are important we will look at them in more detail. You know already that height above sea level on maps is shown by contour lines.

There are some very important aspects about contours which you must know:

- Contour lines may never run across each another.
- However, when slopes are very steep and form a vertical cliff, contour lines may be so close that it seems as if they touch.
- Contour lines may also touch in a waterfall.
- A contour line will either run of a map, or it will link up with itself.

- The distance between consecutive contour lines (called the vertical interval) is always the same on a contour map.
- The height above sea level represented by a contour line is shown in a break in the contour line.

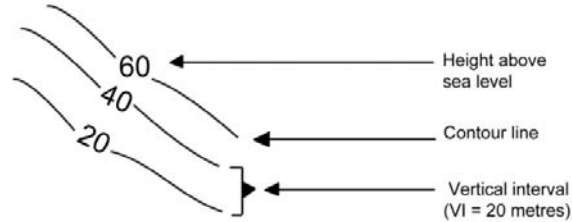
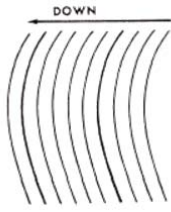

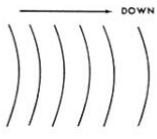

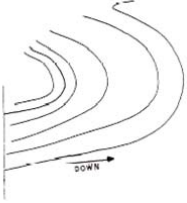



Figure 1.23

- Contour lines can show slopes (Table 1) or landforms (Table 2)

Types of slopes	Description	On a contour map	Cross-section of the area
Steep	Contour lines are close together		
Gentle	Contour lines are far apart		
Even / Uniform	The spacing between contour lines are the same. An even slope can either be steep or gentle.		
Concave slope	Contours are widely spaced (gentle) at lower heights, but close together (steep) at higher heights.		







<p>Convex slope</p>	<p>Contours are close together (steep) at lower heights and widely spaced (gentle) at higher heights.</p>		
<p>Stepped / terraced slope</p>	<p>Pairs of steeply spaced contour lines are separated by areas of gentle slope.</p>		
<p>Vertical slope / cliff</p>	<p>When contours are extremely close together that they touch, or almost touch each other</p>		

Table 1

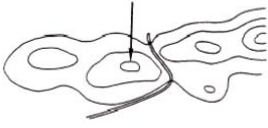
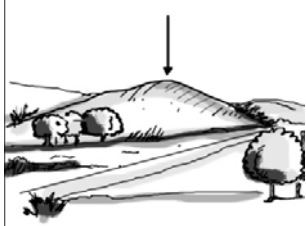
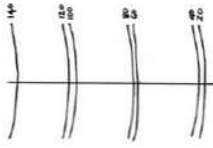
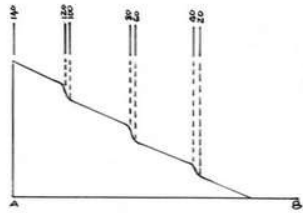
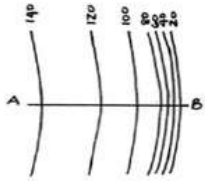
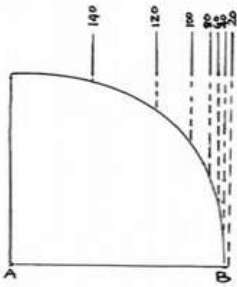
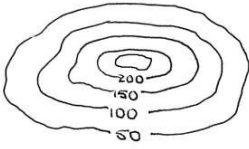
Types of landforms	Description	On a contour map	Cross-section of the area
<p>Conical hill/ pointed butte</p>	<p>A hill where the slopes are similar in all directions. The sides are usually steep with a small pointed top. The contour lines look like concentric circles with the smallest circle in the centre, showing the pointed top.</p>		

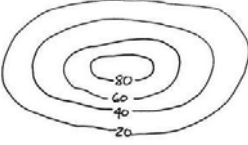
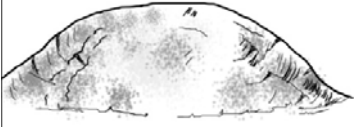
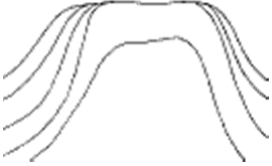
<p>Flat-topped butte</p>	<p>A hill with a flat top. Contours are more oval-shaped. The slopes are more gentle than those of a conical hill.</p> <p>The oval shape in the centre is also larger than the centre of a conical hill and it shows the flat top.</p>		
<p>Plateau</p>	<p>An upland area with steep sides.</p> <p>The contour in the centre is even larger than that of a flat-topped butte.</p> <p>Rivers may carve valleys along the sides of the plateau.</p>		
<p>Valley</p>	<p>The contour lines are 'V' shaped.</p> <p>Valleys are formed when the 'V' points in the direction of higher land.</p> <p>Rivers run in valleys – always from a high to a low point.</p> <p>You must know how to draw a river in a valley and then should remember the point above!</p>		
<p>Waterfall</p>	<p>A waterfall may be created where water drops vertically in a river. This is formed when contour lines in a valley touch.</p>		

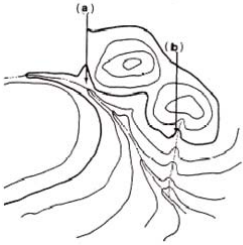
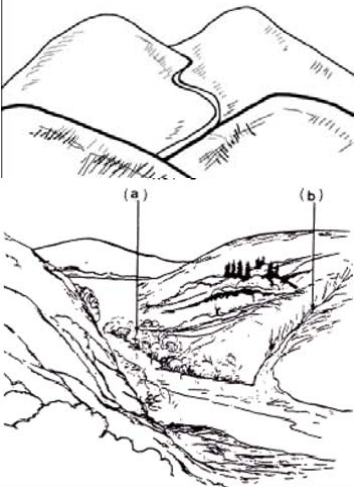
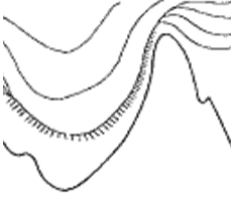
<p>Spur</p>	<p>The ‘opposite’ of a valley, where the ‘V’ points in the direction of lower land.</p>		
<p>Saddle</p>	<p>A low point between two or more higher points in a mountain. The low point (saddle) is still higher than surrounding landscapes.</p>		
<p>Cliff</p>	<p>A vertical slope where the land suddenly drops a few meters or more. Contour lines lie on top of each other to show the vertical slope.</p>		

Table 2

Interpolation of spot heights

Remember that we said earlier that contours are formed when spot heights of the same values are joined by a line. You must be able to do that. Does it sound tricky? No, let me show you.

Look at the map with different spot heights below. You will see that the highest contour values are in the centre, while the values decrease outwards.

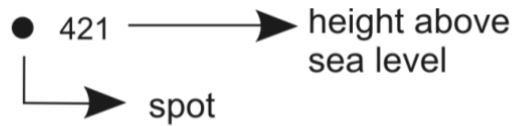

Figure 1.24

Insert map showing spot heights.



Figure 1.25

<http://www.orusovo.com/nammap/>

The highest value is 120, but there is only one 120, which cannot be joined to itself. So now look for the second biggest value, which is 100. Find all the 100's and join them with a line in such a way that everything higher than 100 is on the inside of your line, while everything smaller than 100 is on the outside of your line.

Insert map with completed 100 line

Now find the next highest value, which is 80. Joint all the 80's and remember that everything higher than 80 must be on the inside of your line, while everything smaller than 80 must be on the outside of your line.

Insert map with completed 80 line.

Continue with the next value.



While drawing in the lines, you must remember that these lines may not touch or intersect one another.

The process of connecting spot heights of the same value with each other is called interpolation.

Once you have completed the process, you should be able to identify the type of landform created by the contours. Can you identify the landform shown after connecting the spot heights?

Insert map with completed interpolation.



In-text question

Can you still remember what contour lines are?

I hope you have managed to do the activity.



Activity

Activity 8

Time Required: In this activity you need at most 45 minutes to fully answer the question.

ADD ACTIVITY PLEASE



How long?

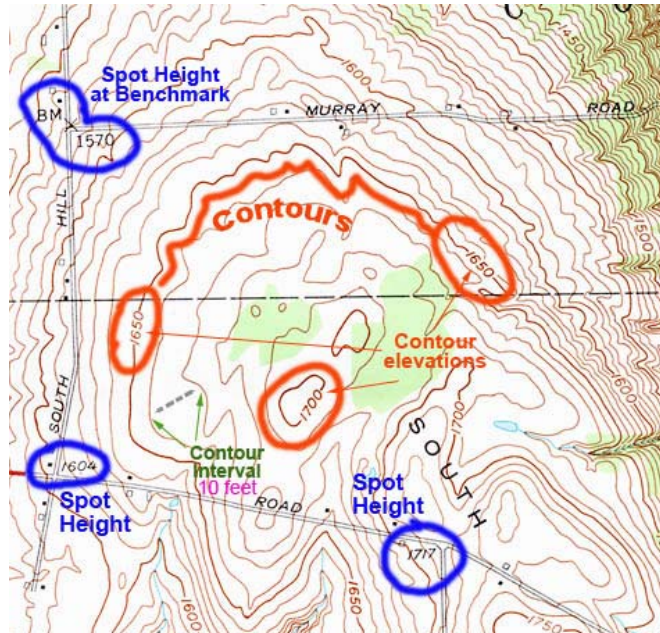

Source: <http://library.buffalo.edu/libraries/asl/maps/cat/images/map-portion-images.html>

Once done with the activity, please compare your answers with mine before you proceed.



Feedback

Let's proceed and look at section 4 which deals with map orientation and determining location in degrees, minutes and seconds.

Section 4

Map orientation/Determining location in Degrees, Minutes and Seconds

Determining location can be easy if you know what to do, but if not it can have devastating effects. A group of students gets lost on an expedition and now they need to find their way home. How will they be able to do that? In this section you will find out how to orientate a map and



They could have checked the coordinates of their location in degrees, minutes and seconds

determine your location. Before you proceed I would like you to take a minute and look at the objectives first.

Upon completion of this section you should be able to:

- *determine* location in degrees, minutes and seconds;
- *orientate* any map.

What does it mean to orientate a map?

It means to determine north on a map and to use the map in order to find direction. To find out more, let us read about the experience of a group of students below.

A group of Geography students from Windhoek went on an expedition to the Namib Desert with their Geography teacher. They went to study wind action and landforms created by wind in deserts. (You will hear more about what they have learned in Unit 4, when 'Erosion' is discussed).

On their way to the research station they found that a long section of the road was flooded so they had to take a detour, which is unknown to the driver. They followed the small gravel road, but could not find the main road again and eventually they were stranded in the middle of nowhere. When emerging from the bus, all they could see was a sea of unending sand and gently rolling dunes. One of the learners made a sketch of the area, which can be found below. Fortunately they have left Windhoek in the very early hours of the morning, which now leave them with many hours of sunshine to find their way to the research station.

Sketch

Figure 1.26

Their teacher took out a topographical map of the area. She also had a small compass which came in very handy. The map is printed below.

Figure 1.27

Answer the following questions by using the sketch and the map in order to help the group find their way to the research station.

1. In which direction were they travelling when they decided to stop and orientate themselves?
2. Instead of using the map, their compass and the sketch, what other means can they use to determine true north?
3. Describe thecomplete

What could the expedition group have done if they had a Global Positioning Satellite System (GPS)?

How do we do that?

When finding the location or position of specific point we make use of lines of latitudes and lines of longitudes and see which lines intersect at that point. The lines of latitudes and longitudes are measured in degrees, e.g. latitudes are running from 0° - 90° North and South of the Equator. Longitudes are running from 0° - 180° West and East of the Greenwich Meridian.

The coordinates of a place can also be called a grid reference. Do you know why? Look at the world map with lines of latitudes and longitudes below. Can you now tell why a location of something can also be called a grid-reference?



Figure 1.28

Source: <http://www.orusovo.com/nammap/>

Can you now determine the location of X? Remember that the latitude is always given first and then the longitude.

For example, the location of X, given in degrees, on the map is (insert coordinates in degrees). Note that the latitude is given first, then the longitude and they are separated by a semi-colon.



But the location given above is still a very large area to go look for lost people.

So now we can narrow down our search by dividing each degree into sixty minutes.

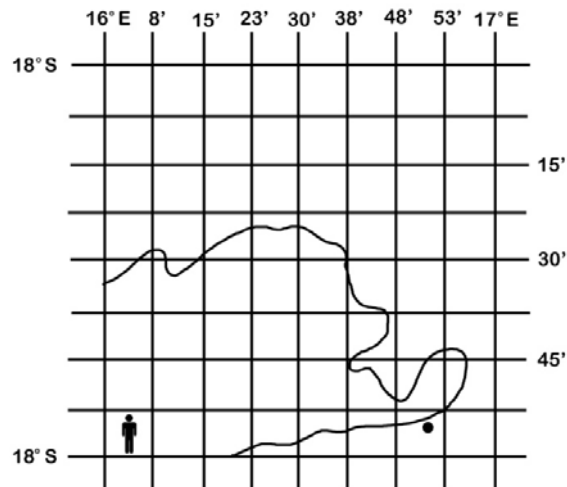

Figure 1.29

Now these lines must be divided into minutes. The position of X must still be shown.

So the location of X given in degrees and minutes is (insert coordinates in degrees and minutes).

So now we have given the location as a four-figure grid reference.

But the process can be narrowed down further by dividing the minutes into seconds. How many seconds are in a minute? Sixty, of course! So now we divide the minutes into sixty seconds.

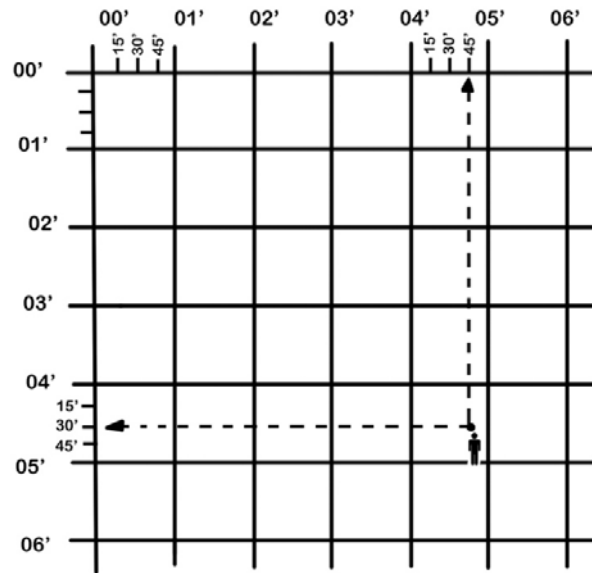

Figure 1.30

Now we can give the six-figure grid reference of X. It is (insert six-figure grid reference).

But how do we know where in the world to look for this grid reference. We need to give directions for the latitudes and longitudes. Let us look The Equator and the Greenwich Meridian divides the world into four quarters. Look at Namibia's position: Namibia lies south of the equator and east of the Greenwich Meridian, so the directions given for latitude will always be south and directions given for longitudes will always be east.

Which directions for latitude and longitude will you use in:

- North America
- Europe
- South America
- Australia?

So now you have to add the directions to your six-figure grid reference which is: (° minutes' seconds" S; ° minutes' seconds" E.)



In-text question

Will you be able to plot a position of a landform or specific man made feature using a six-figure grid reference? If you are not sure go back and read through the content again.

Test your knowledge on determining location by doing the next activity.

Activity 6



Activity



How long?

Time Required: In this activity you need at most 45 minutes to fully answer the question.



Once done with the activity, please compare your answers with mine before you proceed.

1. Can you identify this type of map?
2. By looking at the map, what do you think is missing on the map that would hinder you to orientate the map and to determine your location?

1. *This is a google map. An oblique photo of an area.*

2. *Missing information includes:*

- *Title, date, scale, map symbols, grid lines, north*
- *Without these features it is impossible to orientate a map or to determine your location.*



Feedback

I hope you have managed to do the activity. Let's proceed and look at section 5 which deals with photographs.

Section 5

Photographs

Photographs are very useful in geography because they have a wealth of information that can be used. We will look at three types of photographs

(horizontal or ground level, oblique and vertical photos) advantages and disadvantages, but first let us look at the section outcomes first.

Upon completion of this section you should be able to:



Section outcomes

- obtain geographical information from horizontal and oblique photographs.



Why use photographs?

This is a question we can ask ourselves, but to answer this question let's look at it from a geographical point. Geographers use a wide variety of tools in their studies of environments and communities. These tools assist them to obtain and record more accurate results. In cases where recording data in a written format is too time consuming and not accurate, geographers often rely on a photograph to document the information. Photographs have a number of advantages. They can capture extraordinary detail which lasts forever and it takes less than a second to capture a single image. Photographs are relatively inexpensive to create and it is simple to compare two photographs from different periods in time or from different parts of the world. With this short explanation you will see that photographs have a wealth of information in them and they are used for different purposes. We will look at three different types of photographs and they are:

- (i) Ground level/horizontal photographs
- (ii) Oblique photographs
- (iii) Aerial photographs

Next we will look at the important aspects of each of these photographs.

Ground level photographs

What are ground level photographs?

Ground level photographs are, as the name suggests, is taken from a ground level perspective. The axis of the camera is tilted horizontally when the photo is taken. They record exactly what a person would see if they were standing in the place of the photographer. Ground level photographs are said to give a **horizontal** view and therefore they are also called horizontal photographs.

In geography, ground level photographs are used when conducting a detailed study of people and places in the world. Geographers are likely to use a ground level photograph when they are studying a particular part of an area, rather than analysing spatial distribution and patterns over the whole area.

Advantages and disadvantages

Ground level photographs are useful because:

- They show the landscape in great detail.
- They are also less expensive and easier to produce than oblique and aerial photographs, since ground level photographs do not require the use of any aircraft.
- It is also familiar to the human eye and no need to orientate yourself with regard to this type of photograph.
- Things in the foreground shows more detail than objects in the background.

Horizontal photo



Figure 1.31

Now let's look at some disadvantages of ground level photographs:

- It does not show the entire area, because objects in the front may block important information.
- A person's view is often blocked by tall trees, houses and hills.
- As with an oblique photograph, scale also **diminishes** from the foreground to the background.
- Objects in the foreground blocks those in the background.

Ground level photo



Figure 1.32

Recording and interpreting

Recording and interpreting is a way to keep a record of findings by writing them down. These observations can be categorised into:

Physical features

Every place on the earth's surface has features that distinguish it from other places on earth. Geographers divide these features into either physical or human feature. We will look only at physical and cultural features on the horizontal photographs. These physical features include:

- relief: cliffs, mountains, valleys, glaciers
- vegetation: forests, meadows, woodlands
- climate: tropical, arid, temperate, polar
- soil: texture, colour, structure
- animals: native, introduced species

Cultural features

The artificial features of a district as distinguished from the natural and these include:

- settlement: cities, towns, villages
- transport: train tracks, highways, airports
- population: number, density, age, gender
- landuse: crops, grazing, housing, industry

When interpreting a photograph, you need to **understand** (use factual knowledge to decide) what might be happening and the possible reasons for it. Look at the next photo and ask yourself the following:



Figure 1.33

- What is happening in the photograph?
- What is the reason for this?
- What are the consequences of this?
- What do the features tell us about the people or place?
- What is the most prominent part of the photograph and why?
- Is it likely that this feature has changed over time? Why or why not?
- How do these features affect one another

Remember these are just guiding questions to help you analyse the photograph.

Oblique photographs

Oblique photographs are another type of photograph used by geographers.

What are oblique photographs?

Oblique photographs (also known as oblique aerial photographs or oblique air photographs) are taken from a high point, which is at an angle neither horizontal (ground level photograph) nor perpendicular (vertical aerial photograph) to the area being photographed.

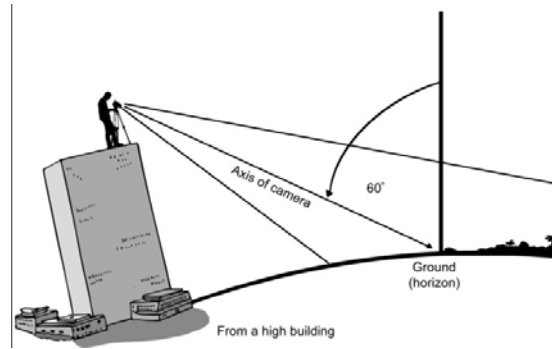

Figure 1.34

This angle is often referred to as a **slope**. Not long after the development of the camera in the 19th century, to achieve photographs from a sloping angle, oblique photographs began to be taken from cameras attached to balloons, kites and even carrier pigeons. With the arrival of modern technology in more recent times, oblique photographs are now taken from an aeroplane or helicopter.

Low oblique photo



Figure 1.35

Oblique photographs are usually divided into two main types. A high oblique photograph features the horizon in the image. A low oblique photograph is directed at a lower angle, which means that the horizon is not visible.

The uses of oblique photographs are endless. Cartographers use them to construct physical and topographical maps. The property and construction industries also use oblique photographs to record and measure properties, as well as to track the progress of development sites.

Advantages and disadvantages

I hope you still remember the advantages of the horizontal photographs in order for you to compare them with the Oblique photographs have a number of advantages. They show more of an area than ground level

photographs, since their view is not obscured by hills, trees or houses. Oblique photographs can also easily be assessed and understood. The perspective of an oblique photograph is similar to that of a conventional (ground-level) photograph, so the physical and cultural features of the landscape are still recognisable. This is unlike vertical aerial photographs which are presented from a map-like perspective.

Another advantage of oblique photographs is that they do not require the aircraft to fly directly overhead the area being photographed. This is particularly useful in the case of photo-reconnaissance by the military.

High oblique



Figure 1.36

A major disadvantage of an oblique photograph is that scale is inconsistent. This means that while distances can be calculated in the foreground, according to the provided scale, distances which are closer to the horizon would be completely inaccurate if calculated using the same scale.

Recording and interpreting

While information can be recorded in a written format, a particularly useful way of recording the information in a photograph is by sketching it. The easiest way to begin a sketch is by tracing the general outline of the image. Once that is done, you should add the physical features, including trees and rivers, and the cultural features, such as houses and roads. It is important for you to label all of these features accurately, so that the sketch can be referred to. When interpreting a photograph, you need to **infer** (use factual knowledge to decide) what might be happening and the possible reasons for it. Some sample questions which you should attempt to answer include:

- What is happening in the photograph?
- What is the reason for this?
- What are the consequences of this?
- What do the features tell us about the people or place?

- What is the most prominent part of the photograph and why?
- Is it likely that this feature has changed over time? Why or why not?
- How do these features affect one another?

Aerial Photographs

Introduction

Aerial photographs are usually taken using a camera mounted on the bottom of an aircraft. Aerial photographs are usually taken from aircraft flying up to six kilometres above the Earth's surface.

Aerial photo

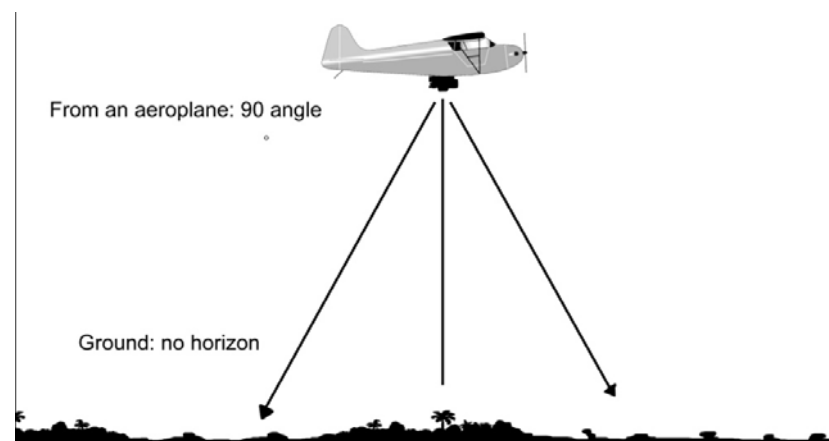

Figure 1.37

Aerial photographs are of particular use to geographers and cartographers. When taken from a relatively low altitude, they are also used to plan towns and structures, accurately measure roads and rivers, survey the resources of an area, and show how the physical and cultural features of a place have changed over time.

Advantages and disadvantages

Aerial photographs have an advantage over ground level photographs. An aerial view enables the whole of an area to be observed, rather than just a portion of it. Aerial photographs are also sometimes favoured over oblique photographs. The reason for this is that the scale of aerial photographs is relatively consistent throughout the entire frame. This enables relatively accurate measurements to be made using photographs taken from this vertical view.

The main disadvantage of aerial photographs is that the point of view is unfamiliar. Most features look very different when viewed from above. This can make it difficult to recognise ground features.

Recording and interpreting



Figure 1.38

There are two ways to record a photograph. It can be sketched or it can be described. When a person interprets information in a vertical photograph, the unfamiliar view means that it is not always easy to immediately identify all of the features. It is often easier to record observations by describing them in terms of their:

Shape

1. What basic geometric shape (square, circle, triangle etc.) does it resemble?
2. What sort of lines (long or short, straight or curved) does it comprise?

Size

1. Is it larger or smaller in size than the objects around it (or similar to it)?
2. According to the provided scale, how large is the object in the real world?

Shadow

1. What direction is the shadow facing? What position is the sun in?
2. What shape is the shadow? What could it be representing?
3. Is the shadow long or short? What time of day could this suggest?



Figure 1.39

Tone (lightness or darkness)

1. Vegetation, especially in forests, usually has a dark tone.
2. The sandy shores of beaches usually appear light.
3. Roads can vary from being grey in tone (highways) to light (unsealed roads).

Associated features

1. A winding line, which is lined by trees, is most likely to be a river.
2. A group of small squares bunched together is likely to be a town.
3. A cluster of evenly spaced trees is most likely to be an orchard.

Once all of this information has been collected, students need to interpret it. Aerial photographs are particularly interesting to interpret because they show such a large area in a simple, map-like format. This enables students to not only interpret a large number of features but also interpret the patterns created. These patterns provide an insight into landuse, vegetation, transport, settlement and relief



In-text question

Will you be able to identify different types of photographs? I am sure you will be able to

To test your knowledge on photographs by looking at the different types of photographs again quickly and then do the activity.

Activity 6



Activity

Time Required: In this activity you need at most 45 minutes to fully answer the question.

Look at the picture below and answer the following questions.



How long?



1. Can you tell us what time of day this picture was taken? Motivate your answer.
2. Write down all manmade features visible on the photograph.

Once done with the activity, please compare your answers with mine before you proceed.



Feedback

-
1. *By looking at the shadows and the direction it falls it looks like it was taken in the afternoon. Cars are standing in the afternoon shade.*
 2. *Dam wall, parking area where cars are standing, a road*

I hope you have managed to do the activity. Let's proceed and look at section 6 which deals with map orientation and height representation.

Section 6

Finding direction/map orientation

We are constantly looking maps and places that we want to visit, but do we know where it is situated? Not always and we are sometimes not sure if the place is west, east, north or south of us. In this section we will explain direction to you. Look at the section outcome first.

Upon completion of this section you should be able to:



Section outcomes

- determine direction from one place to another on a map, by using the 16 divisions of direction
- orientate any map

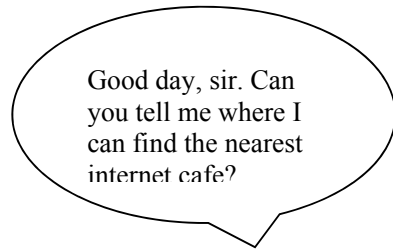

Insert picture of tourist who is lost

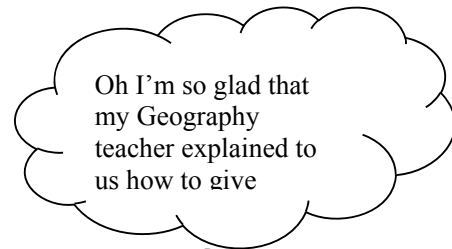

Insert picture of a funky teenage girl.

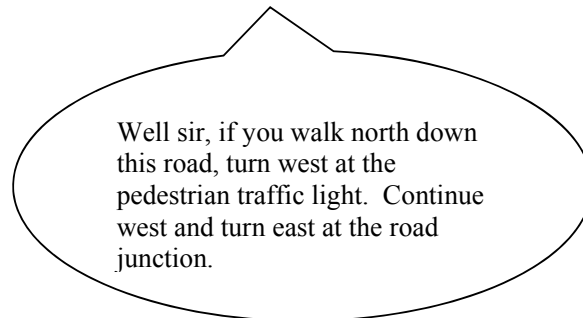

As we can see from the above conversation it is important to know directions. Whenever you walk or drive from one place to another you walk or drive in a specific direction. It is also important to know the different directions because it can be used to find your way in an unknown area or you can use directions to help someone who is lost find his way.

A compass is used to determine direction. Look at the compass below and see if you can identify the following parts:

- Compass needle
- 16 different directions



Figure 1.40

Source: <http://en.wikipedia.org/wiki/Compass>

Do you notice something ‘funny’ about the needle? Yes, it does not point ‘north’ but slightly deviates to the left. This is called Magnetic North. North on the compass is True North, which is the direction towards the North Pole. The difference between True North and Magnetic North is called ‘magnetic declination’. The angle of deviation is 23.5° . But how do we give directions from a map?

Direction on a map is given by using the 16 points of a compass. But if you do not have a compass to find out where ‘North’ is, you must look for an arrow on the map or in the margin of it. The arrow shows us where ‘north’ is. Below are examples of arrows:

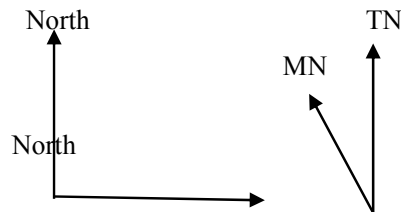

Figure 1.41

To make it easier to understand we will first look at the 4 main points on a compass, consisting of north (N), south (S), west (W) and east (E).

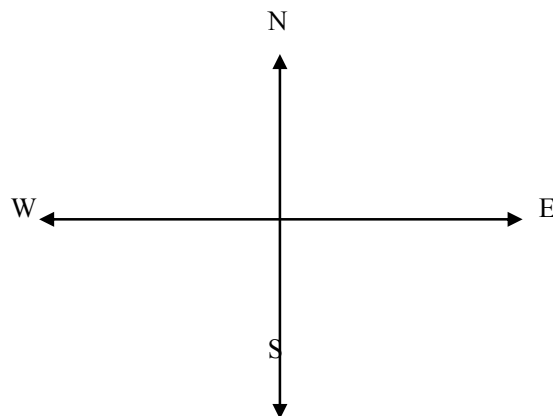

Figure 1.42

These four directions are then divided into another 4 intermediate directions:

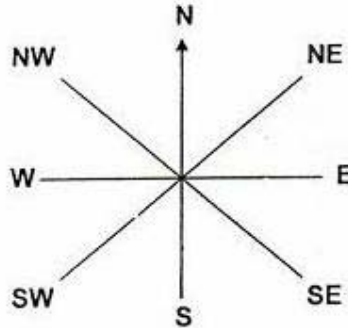

Figure 1.43

The four intermediate directions are: north-east (NE), south-east (SE), southwest (SW), south-east (SE)

Then another eight directions are placed in between. These are additional intermediate directions and they are: north-north east (NNE), east-northeast (ENE), east-south east (ESE), south-southeast (SSE), south-southwest (SSW), west-southwest (WSW), west-northwest (WNN), north-northwest (NNW).

Can you complete the missing directions on the 16-point compass below:

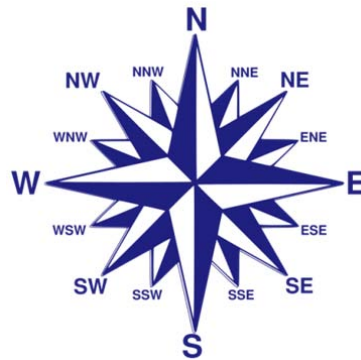

Figure 1.44

Source: http://www.alaboola.com/lists/6/16_Point_Compass.php

Now that we know directions how is it used?

Directions are given by starting at the point after the word 'from'.

Let us find the direction from A to B.

B●

●A



1. Draw a small compass on the starting point, which is 'A' because we want to find the direction from A to B.

B●



Connect the two points with a straight line.

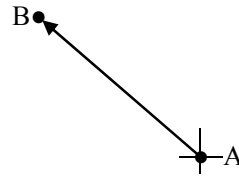

3. Find the direction, which is north-west.

Look at the next example.

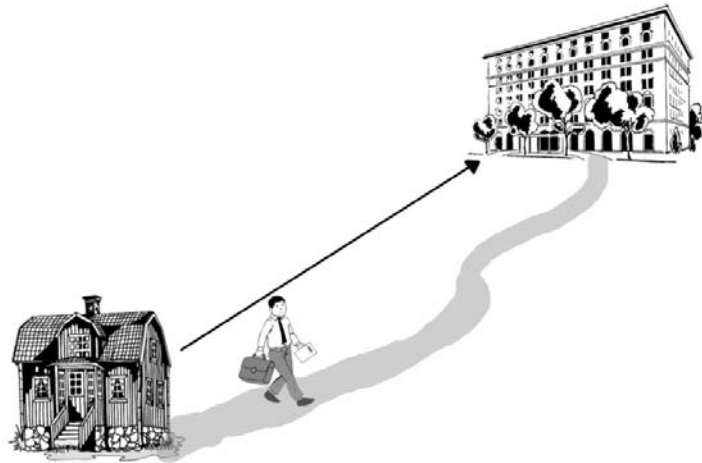

Figure 1.45

The boy is walking from his house to school. So we take direction from the house to the school which is north-east.

In which direction would the boy walk if he comes home from school?

Now determine the following directions:

Activity 7



Time Required: In this activity you need at most 45 minutes to fully answer the question.

Activity



How long?

Look at the street map on direction below and answer the following questions.

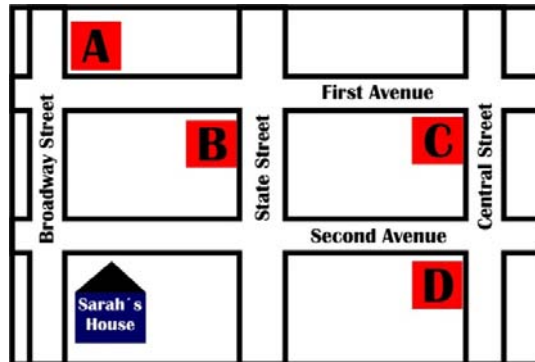

Source:

<http://www.englishexercises.org/makeagame/viewgame.asp?id=2752>

1. Sarah's house isfrom A and of B, but from C and exactly..... of D.
2. If you stand with your back towards A, D liesin front of you and Sarah's house.....

Once done with the activity, please compare your answers with mine before you proceed.

1. *South, NNE, SW, W*
2. *SE and S*



Feedback

Map orientation

It does not just mean to put the map on a flat surface, but more accurately to enable you to know exactly where you are. This will be explained to you in this section, but I want you to look at the outcome first.

What does it mean to orientate a map?

It means to determine north on a map and to use the map in order to find direction. To find out more, let us read about the experience of a group of students below.

A group of Geography students from Windhoek went on an expedition to the Namib Desert with their Geography teacher. They went to study wind action and landforms created by wind in deserts. (You will hear more about what they have learned in Unit 4, when 'Erosion' is discussed.

On their way to the research station they found that a long section of the road was flooded so they had to take a detour, which is unknown to the driver. They followed the small gravel road, but could not find the main road again and eventually they were stranded in the middle of nowhere. When emerging from the bus, all they could see was a sea of unending sand and gently rolling dunes. One of the learners made a sketch of the area, which can be found below. Fortunately they have left Windhoek in the very early hours of the morning, which now leave them with many hours of sunshine to find their way to the research station.

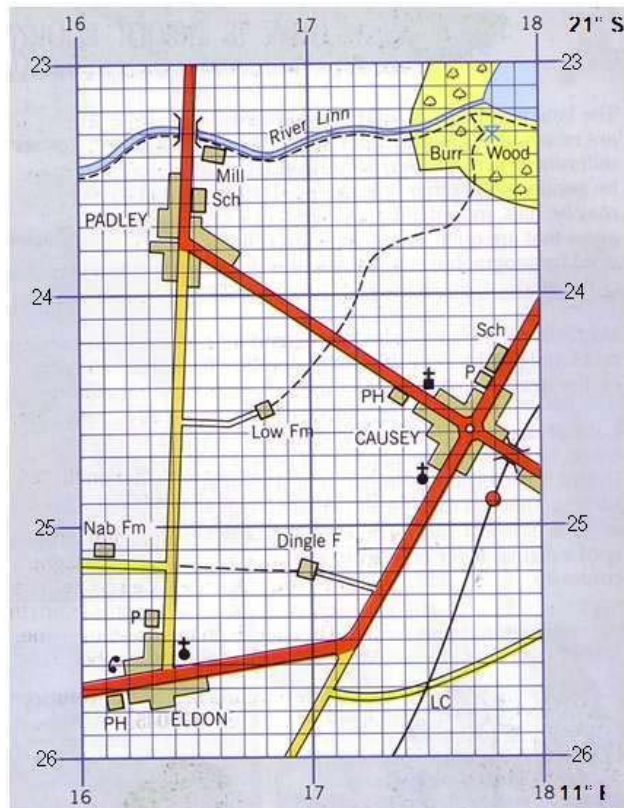

Figure 1. 46 (Map should be replaced) Insert sketch

Their teacher took out a topographical map of the area. She also had a small compass which came in very handy. The map is printed below.

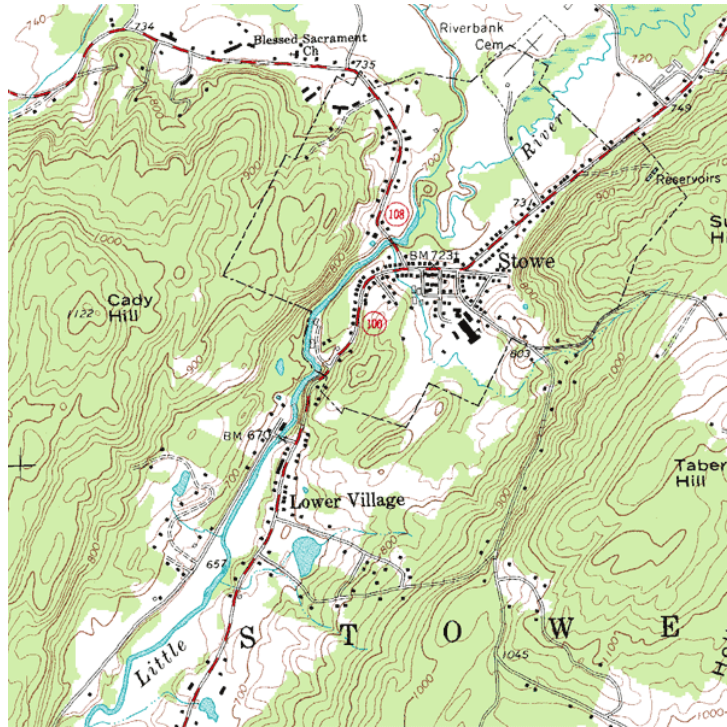

Figure 1. 47 (Map should be replaced) Insert topographical map.

Activity 9



Activity

Time Required: In this activity you need at most 45 minutes to fully answer the question.



How long?

Look at the sketched map (Figure1) and answer the following questions.

Answer the following questions by using the sketch and the map in order to help the group find their way to the research station.

1. In which direction were they travelling when they decided to stop and orientate themselves? [1]
2. The location of the research station is shown on the map. Is the group able to see it from their current position? [1]
3. Explain your answer in question 2. [1]
4. Determine the six-figure grid reference of the research station. [3]
5. Determine their location, giving the six-figure grid reference. [3]
6. Determine the bearing from grid north of their position to the research station. [1]
7. Describe the landscape and natural vegetation in their immediate surrounding area. [4]
8. Instead of using the map, their compass and the sketch, what other means can they use to determine true north? [1]
9. Describe the easiest route which they could follow, using directions to get to the road which will take them to the research station. [4]
10. Calculate the distance along the route which you have described in question 9. Give your answer in kilometres. [2]

Once done with the activity, please compare your answers with mine before you proceed.

Yolande needs to provide the answers



Feedback

Section 7

Determining bearings

Let us look at the section outcomes first.

Upon completion of this section you should be able to:



- *determine* bearings from a grid north from one place to another.

Section outcomes

Bearings are directions given in degrees. Below is a 16-point compass with the 16 corresponding degrees which show the bearings.

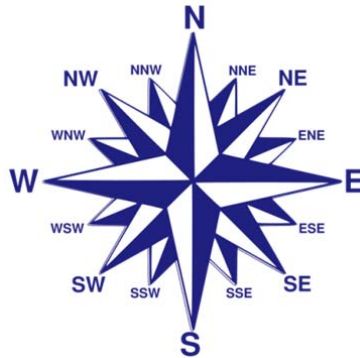

Figure 1.48

Source: http://www.alaboola.com/lists/6/16_Point_Compass.php

(Insert 16-point compass with directions and degrees).

Let us determine the bearing from A to B in the following example. Bearings are measured with a protractor and we always work in a clockwise direction from north. Note that on the compass 'north' is 0° and the number increase towards the right which is clockwise. That is why we work from 'north' or 0° in a clockwise direction.

B •

Figure 1.49

A •

1. Draw straight line on the starting point, which is 'A' because we want to measure the bearing from A to B and connect the two points with a straight line.

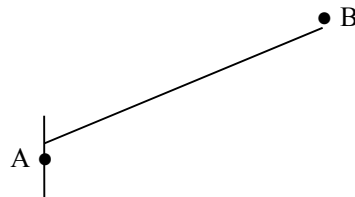

Figure 1.50



2. Place the centre of your protractor (which is normally a small dot or 'cross') on A. Sometimes it may be necessary to make the line that connects the two points longer so that it runs beyond your protractor.
3. Now move your finger clockwise from the '0' until you come to your connection line.
4. Now you can read the bearing from the protractor.

(insert picture to illustrate 3 and 4).

But what then if you must find the bearing from 'B' to 'A'?

1. Repeat step 1 above.
2. But now you do not need to measure the angle from '0' because from north to south the degrees is 180° (refer to the 16-point compass above). However, you must now turn your protractor left so that the '0' points down. Place your finger on the '0'.
3. Now move your finger clockwise until you come to your connection line.
4. Take the measurement in degrees.
5. The bearing will be your reading + 180° .

(Insert diagram illustrating the above, with real values to come up with an answer in step 5.)

Now try to determine the following bearings:

Activity 8

Time Required: In this activity you need at most 45 minutes to fully answer the question.



Activity



How long?

Look at the picture below and answer the following questions.



Source:

<http://www.englishexercises.org/makeagame/viewgame.asp?id=2752>

1. What is the bearing from the point marked "Start here" to the Castle.
2. If you are standing at the Castle, what would the bearing be to the cinema?

Once done with the activity, please compare your answers with mine before you proceed.

1. 45°

2. 270°



Feedback

Section 8

Draw cross-section and inter-visibility

Practical applications in geography are also an important part and to do that is a skill, but we will show you how to do it. Remember we show you how to measure a curved distance. In the same way we will walk you step by step in drawing a cross-section. It is once again that you look at the section outcome first.

Upon completion of this section you should be able to:



Section outcomes

- draw simple freehand cross-sections and determine intervisibility.

A cross-section of a contour map can be drawn to show what the landscape looks like from the side. Imagine when cutting an orange in half, you would then have a cross-section of the orange.

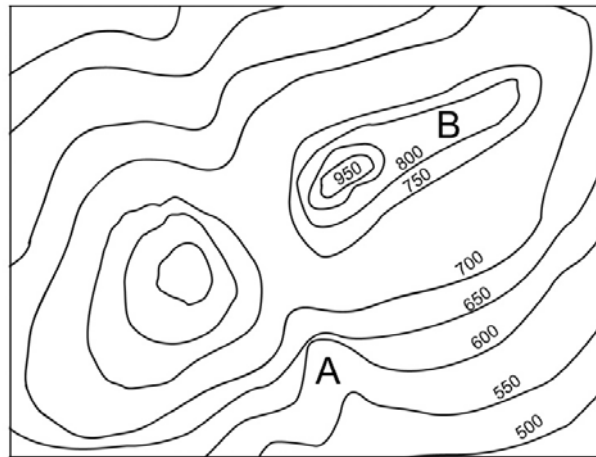

Figure 1.51 (a)

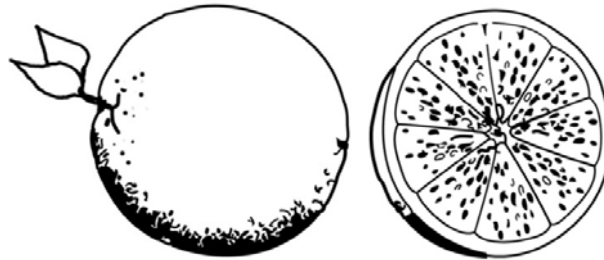

Figure 1.51 (b)

Follow the steps below to draw a cross-section of the contour map above.

1. Take a piece of paper and place it along the line between X and Y on the contour map.

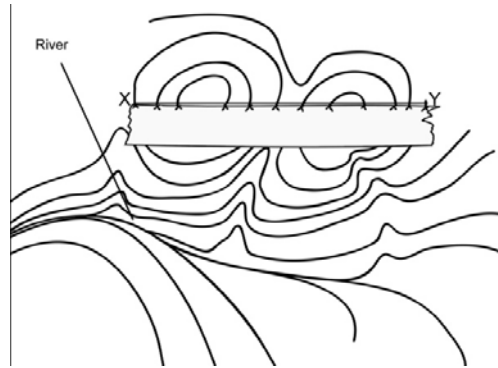

Figure 1.52

2. On your paper, tick off all the contour lines that are 'cut' by line XY. Also indicate the position of the river.

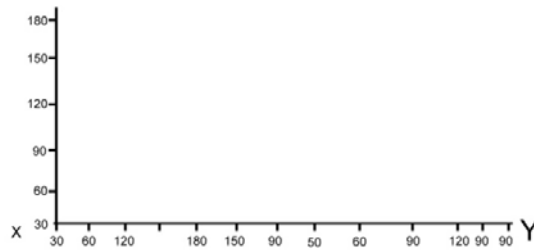

Figure 1.53 (a)

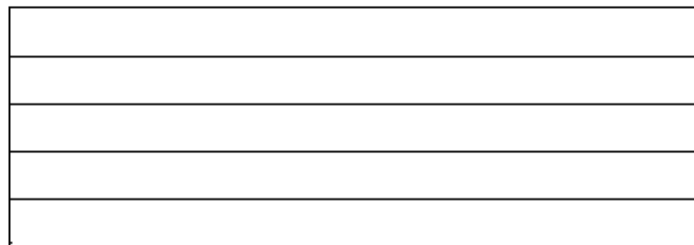

Figure 1.53 (b)

3. Now transfer the values of the contour lines which are 'cut' by line XY onto your paper.

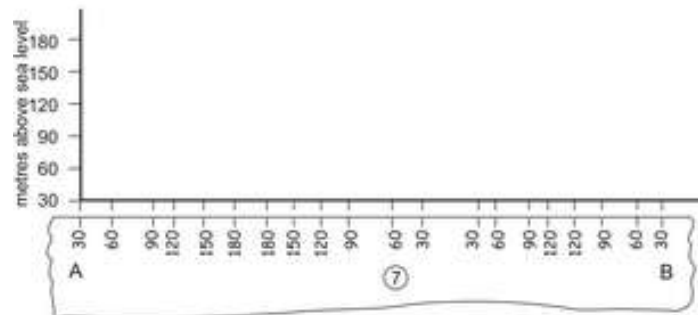

Figure 1.54 (a)

4. Transfer the values to the horizontal axis of a graph. The horizontal axis must be the exact same length of XY on the contour map. Label X and Y on your horizontal axis.

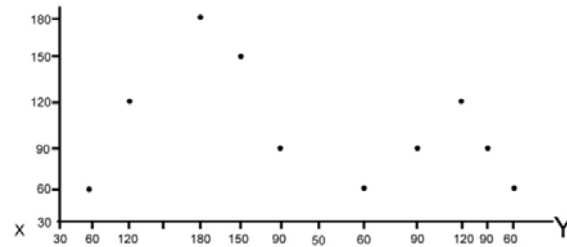

Figure 1.54 (b)

5. Draw a vertical axis for your graph. Use a vertical scale of 1cm = 100m. The highest value on your vertical axis must correspond with the highest value of the horizontal axis.

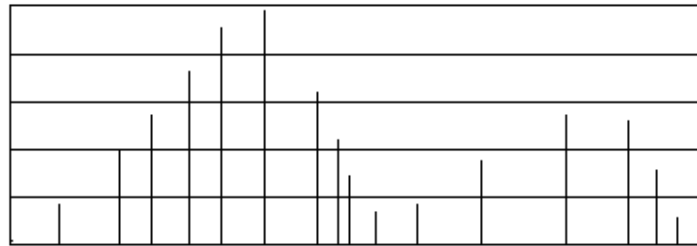

Figure 1.55

6. Now make dots or crosses on the graph where the values on the horizontal axis intersect with the same values on the vertical axis.

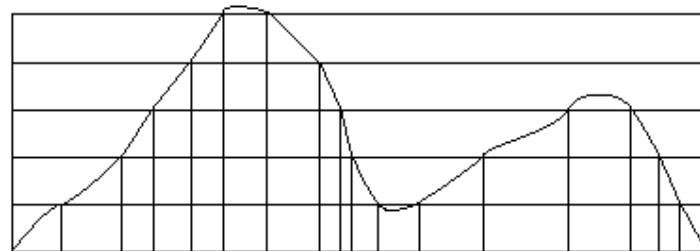

Figure 1.56

7. Now connect the dots, starting at X and ending at Y. Remember to make a slightly downwards rounded shape when you come to the river, t indicates the channel of the river. Use your free hand to connect the dots and not a ruler; otherwise your cross-section will not be a true reflection of a valley.

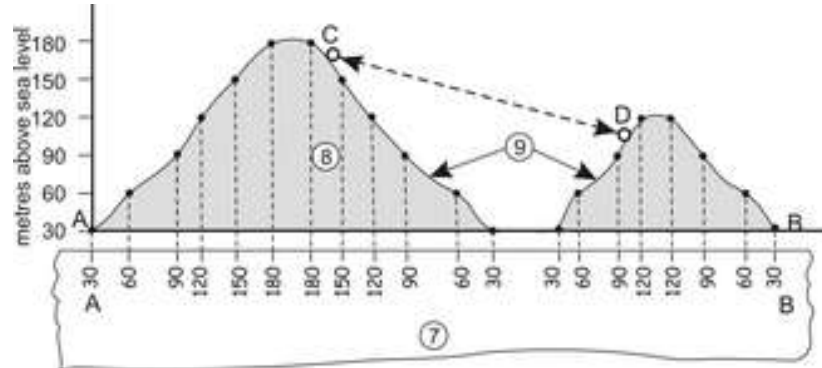

Figure 1.57

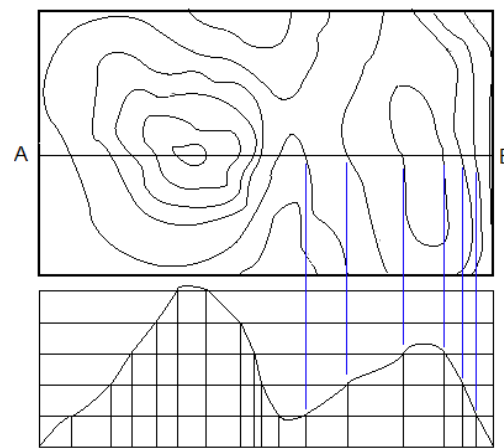

Figure: 1.58

When we have completed a cross-section of an area, intervisibility can be determined. This means whether one person who stands at the first point can actually see someone standing on the other end of the cross-section. If these two people can see each other, then the two points are intervisible.



Figure 1.59

If the one point cannot be seen from the other, the land which is not visible is referred to as dead ground.



Figure 1.60

Activity



Activity



How long?

Time Required: In this activity you need at most 45 minutes to fully answer the question.

Look at the map below and do the activity.



Source:

<http://www.eps.mq.edu.au/courses/GEOS264/maps/mapch3/conts.htm>

Once done with the activity, please compare your answers with mine before you proceed.

Draw a cross-section from A to B.



Feedback



Unit summary



Summary

In this unit you have learned the following:

We discussed the interpretation of maps by looking at human and physical aspects. In our discussion we explained what are maps and what are they used for and also the title, date, scale, map symbols. In summary we can say that a map is a picture or representation of the Earth's surface. You also should start by describing what the map shows and the main area it covers, but only if this is not simply repeating the caption.

Avoid unnecessary detail, but if relevant:

- Describe the scale and list the key items;
- State the orientation and use 'north, east, south and west' not 'up, down, left and right'.

Remember each map has a title with the following information on it e.g. 2217 BA Namibia. The 22 represents the line of latitude and the 17 the line of longitude. BA is the specific map of the B block.

The date on the other hand shows when this map was drawn. Dates are very important seeing that information might be missing and we will only know it if we looked at the date.

Each map has its own scale and you must know the difference especially if you calculate distance. Three types of scale are used e.g. ratio, word and linear scale. The map scale on the other hand lets you know by how much the distances have been scaled down so you can calculate the real-world distance between different points on the map. To do this, you need to know the distance on the map and the scale factor. Remember there are 1000 metres in 1 kilometre.

And then we also need map symbols and they are divided into three groups: **point**, **line** and **area symbols**.

Then you should remember how to measure straight line and curved distances (see page 29).

A topographic map is a detailed and accurate graphic representation of cultural and natural features on the ground.

Contour lines are lines drawn on a map connecting points of equal elevation.

A landform or physical feature in the earth sciences is defined by its surface form and location in the landscape, as part of the terrain, and as such, is typically an element of topography. Landform elements include spurs, valleys, hills, cliffs, canyons, waterfalls, deserts etc. It means to determine north on a map and to use the map in order to find direction.

Photographs have a number of advantages. They can capture

extraordinary detail which lasts forever and it takes less than a second to capture a single image. Photographs are relatively inexpensive to create and it is simple to compare two photographs from different periods in time or from different parts of the world. The three different types of photographs are:

- (i) Ground level/horizontal photographs
- (ii) Oblique photographs
- (iii) Aerial photographs

Height on maps can be shown by means of contour lines, spot heights and trigonometrical beacons.

A cross-section of a contour map can be drawn to show what the landscape looks like from the side. Imagine when cutting an orange in half, you would then have a cross-section of the orange.

Assessment



Assessment

1. Study the map below and answer the questions which follow.

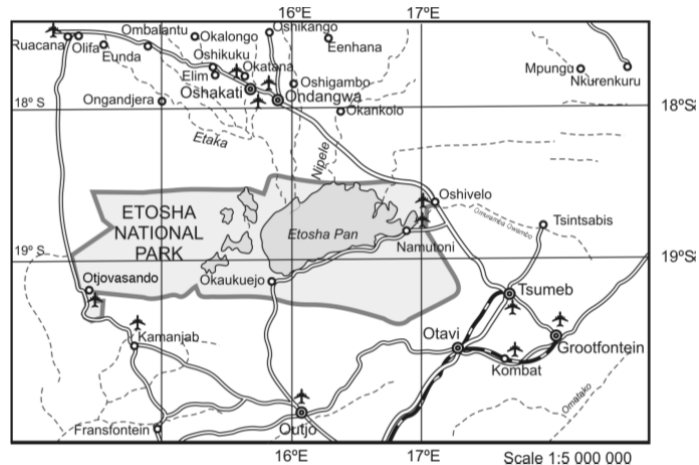

- Identify the type of scale used on Map. (1)
- Calculate the straight line distance between Oshivelo and Ondangwa. (3)
- Convert the scale from ratio to word scale. (1)
- What is the bearing of Kamanjab from Namutoni? (2)

2. Study the contour map below and answer questions which follow.

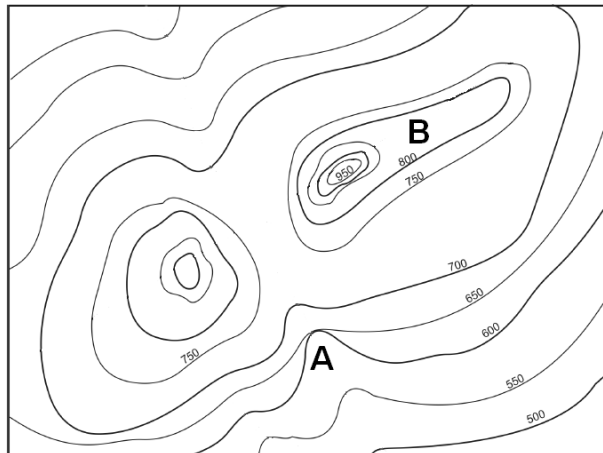

- What is the vertical interval of this map? (1)
- Draw in two rivers on the contour map and show the direction of flow with an arrow. (4)
- Using an X, mark the position of a saddle. Mark a with an X a position of a saddle (Sentence not clear) (1)
- Identify the landforms marked A and B. (2)

(e) Use the contour map and shade all areas higher than 800 m above sea level. (2)

3. Study the two types of photographs below and answer the questions that follow (copy two photographs from the textbook: A=horizontal B= oblique).

a) Identify the types of photographs A and B. (2)



b) Name two advantages and two disadvantages of the two types of photographs identified in 3a above. (4)

c) What is the scale of the photograph if the women standing in front with the bucket are both 1.4 m tall? (2)



Formula: $\frac{\text{actual known height, length or breadth of object}}{\text{Height, length or breadth of object on photograph.}}$

TOTAL: 25



References



References

<http://www.skwirk.com.au/search/search-results.asp>

<http://www.teachnet.uk.org.uk>

http://www.ehow.com/how_6193164

[calculate-distance-using-map-scale.html](http://www.ehow.com/how_6193164_calculate-distance-using-map-scale.html)

<http://www.bbc.co.uk/skillswise/numbers/measuring/distance/worksheet1.shtml>

<http://raider.mountunion.edu/~mcnaugma/Topographic%20Maps/contour.htm>

http://en.wikipedia.org/wiki/Fish_River_Canyon

<http://en.wikipedia.org/wiki/Sesriem>

<http://www.google.com/na/imgres?imgurl=http://www.phototravels.net/namibia/ndp2/namib-desert-air-p->

<http://raider.mountunion.edu/~mcnaugma/Topographic%20Maps/contour.htm>

<http://en.wikipedia.org/wiki/Landform>

<http://worldlandforms.com/landforms/>

<http://www.google.com/na/imgres?imgurl=http://www.phototravels.net/namibia/ndp2/namib-desert-air-p->

[50.2.jpg&imgrefurl=http://www.phototravels.net/namibia/namib-desert-aerial-](http://www.phototravels.net/namibia/namib-desert-aerial-)

[vast.html&usq=__bvLiRhsvRdvYxjfW7rlh4loZYDw=&h=328&w=490&sz=28&hl=en&start=1&zoom=1&itbs=1&tbnid=5vvNrBOxYVFYtM:&tbnh=87&tbnw=130&prev=/images%3Fq%3Dnamib%2Bdesert%26hl%3Den%26sa%3DX%26biw%3D1280%26bih%3D607%26site%3Dsearch%26tbs%3Disch:1%26prmd%3Divnsm&ei=AS2QTbTINY-6vQOwqYSxDQ](http://www.phototravels.net/namibia/namib-desert-aerial-vast.html&usq=__bvLiRhsvRdvYxjfW7rlh4loZYDw=&h=328&w=490&sz=28&hl=en&start=1&zoom=1&itbs=1&tbnid=5vvNrBOxYVFYtM:&tbnh=87&tbnw=130&prev=/images%3Fq%3Dnamib%2Bdesert%26hl%3Den%26sa%3DX%26biw%3D1280%26bih%3D607%26site%3Dsearch%26tbs%3Disch:1%26prmd%3Divnsm&ei=AS2QTbTINY-6vQOwqYSxDQ)

<http://en.wikipedia.org/wiki/Compass>

http://www.alaboola.com/lists/6/16_Point_Compass.php

<http://www.englishexercises.org/makeagame/viewgame.asp?id=2752>

<http://www.englishexercises.org/makeagame/viewgame.asp?id=2752>

<http://www.google.com/na/imgres?imgurl=http://www.askaboutireland.ie/learning-zone/primary-students/please-select/5th-+6th-class/geography/maps-and-map-reading/landscape-features/spot-heights-and-trig-poi/>

<http://library.buffalo.edu/libraries/asl/maps/cat/images/map-portion-images.html>

<http://www.eps.mq.edu.au/courses/GEOS264/maps/mapch3/conts.htm>

<http://raider.mountainunion.edu/~mcnaugma/Topographic%20Maps/contour.htm>

<http://en.wikipedia.org/wiki/Landform>

<http://worldlandforms.com/landforms/>

http://www.google.com/na/imgres?imgurl=http://www.phototravels.net/namibia/ndp2/namib-desert-air-p-50.2.jpg&imgrefurl=http://www.phototravels.net/namibia/namib-desert-aerial-vast.html&usq=__bvLiRhsvRdvYxjfW7rlh4loZYDw=&h=328&w=490&sz=28&hl=en&start=1&zoom=1&itbs=1&tbnid=5vvNrBOxYVFYtM:&tbnh=87&tbnw=130&prev=/images%3Fq%3Dnamib%2Bdesert%26hl%3Den%26sa%3DX%26biw%3D1280%26bih%3D607%26site%3Dsearch%26tbs%3Disch:1%26prmd%3Divnsm&ei=AS2QTbTINY-6vQOwqYSxDQ

http://en.wikipedia.org/wiki/Fish_River_Canyon

Feedback for Assessment



Assessment

1.(a) ratio scale

(b) $\frac{36\text{mm} \times 5\,000\,000}{1\,000\,000} = 36 \times 5$

= 180km

c) 1centimetre equals 50km

d)250 degrees

2.(a) 50m

(b) draw in on contour map

c) on contour map

(d) A = Waterfall

B = Plateau

(e) on map

3. (a) A = Horizontal photograph

B = Oblique photograph

b) A : advantages – the human eye is familiar with this type of photograph



-the foreground shows a lot of detail

B : advantages – show a larger area

-show much more information

A: disadvantages –show a small area

-information is hidden

B : disadvantages – there is less detail in the foreground

-cannot use them to draw maps, because it

will have a negative effect on the map scale

c) 140cm

3,6cm

= 1:39

TOTAL:25

Unit 2

Climatology

Introduction

Climatology is the study of climates. In this unit you will study the difference between weather and climate, and how to record weather by using different weather instruments. You will also learn about different climatic maps and how to use them, and about air pressure systems and how they influence the climate of Namibia. First I want you to study the outcomes of this unit first.

Upon completion of this unit you should be able to:



Outcomes

- *use* the weather instruments;
- *record* weather observations continuously;
- *draw* and interpret graphs of temperature (line graph), rainfall; data (bar graph), wind direction (wind rose);
- *analyse* weather data and make calculations (e.g., total, average and range.);
- *define*:
 - (a) isotherms
 - (b) isobars
 - (c) isohyets.
- *interpret* climatic maps;
- *describe* high and low pressure systems and identify them on a map;
- *describe* the weather associated with high and low pressure systems;
- *draw* sketches representing vertical and horizontal air movements in relation to high and low pressure systems;
- *describe* (a), (b) and (c) below and explain their influence on local climate:
 - (a) land and sea breezes
 - (b) valley and mountain breezes
 - (c) Berg winds

Now that you have studied the outcomes and know what is expected of you I want you to look at the timeframe first to see how much time is needed to complete this unit.



How long?

You will need approximately 25 hours to complete the unit.

Now that you have familiarize yourself with the time study the following terminologies first.



Terminology

weather:	Weather refers to the conditions of the atmosphere over a short period of time
climate:	Climate refers to the average atmospheric conditions of a certain area
isobars:	Are lines that connect all places with the same air pressure
isotherms:	Are lines that connect places with equal temperature
isohyets:	Are lines that connect places with the same rainfall
low pressure systems:	Are also called cyclones or depressions. Cyclones rotate clockwise
high pressure systems:	Anti-cyclones rotate anti-clockwise
average:	Averages are calculated by adding up the individual numbers that were recorded and then dividing this answer by the number of data items that you have added up
range:	The temperature range is the difference between the highest and lowest daily, monthly or yearly temperatures
precipitation:	Rainfall is a form of precipitation and is measured in millimetres using a rain gauge
dew point:	The temperature at which the air becomes saturated and condensation takes place
weather elements:	It includes temperature, air pressure, humidity, rainfall, wind speed, wind direction and sunshine
synoptic weather map:	All weather information is indicated (summarized) on a synoptic weather map, which is then used to make weather forecasts
temperature:	Temperature is how warm or cold the surrounding air is
humidity:	Humidity is the amount of water vapour in the air and is expressed as a percentage (%)
air pressure:	Air pressure is the force with which the atmosphere (air) is pressing down on us. It is measured in units called millibars (mb) or hectopascals (hPa), by means of a barometer or a barograph
wind:	Wind is moving air and it is described by the compass direction from where it is blowing, for example, north, south-east, etc.
wind direction:	Always remember that a wind is named after the direction from where it comes. So, a north wind

wind speed:	blows from the north! The speed at which the wind is blowing and it is measured with a cup anemometer
ascending air:	Means rising air (warm air rise)
descending air:	Sinking air (cold air sinks)

Section 1

Weather: elements, instruments and data

To study the weather it is imperative that we acquaint ourselves with the weather instruments and their use. This knowledge that you will gain will enable you to understand the difference between weather and climate. We will not only introduce you to the weather elements, but you will be made aware of the three main elements of weather and climate, the instruments used to measure these elements and how to use the data collected from these instruments. Let's look at the section outcomes first before we continue.

Upon completion of this section you should be able to:



Section outcomes

- *recognise* the different weather instruments and know how to collect and record climatological data;
- *analyse* the recorded data and draw certain graphs.

Weather Instruments

Meteorologists use a variety of instruments to measure the weather to give an accurate reading of what the weather is like. Here are some of those very important instruments:

A barometer

A **barometer** is a scientific instrument used in meteorology to measure atmospheric pressure. It can measure the pressure exerted by the atmosphere by using water, air, or mercury. Pressure tendency can forecast short term changes in the weather.

Types

Water-based barometers

This one will not be explained, only mercury barometers.

Mercury barometers

A mercury barometer has a glass tube of at least 84 cm in height, closed at one end, with an open mercury-filled reservoir at the base. The weight of the mercury creates a vacuum in the top of the tube. Mercury in the tube adjusts until the weight of the mercury column balances the atmospheric force exerted on the reservoir. High atmospheric pressure places more force on the reservoir, forcing mercury higher in the column.



Low pressure allows the mercury to drop to a lower level in the column by lowering the force placed on the reservoir. Since higher temperature at the instrument will reduce the density of the mercury, the scale for reading the height of the mercury is adjusted to compensate for this effect.

Torricelli documented that the height of the mercury in a barometer changed slightly each day and concluded that this was due to the changing pressure in the atmosphere.

1 atmosphere is equivalent to about 760 millimetres, of mercury.

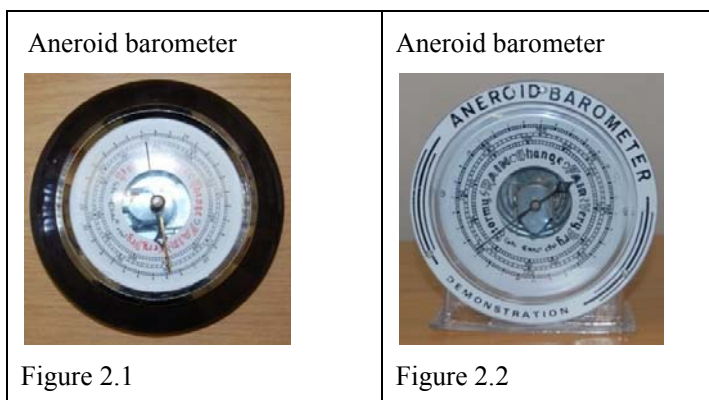

An **aneroid barometer**, invented by the French 19th century engineer and inventor Lucien Vidie, uses a small, flexible metal box called an aneroid cell. This aneroid capsule (cell) is made from an alloy of beryllium and copper. The evacuated capsule (or usually more capsules) is prevented from collapsing by a strong spring. Small changes in external air pressure cause the cell to expand or contract. This expansion and contraction drives mechanical levers such that the tiny movements of the capsule are amplified and displayed on the face of the aneroid barometer. Many models include a manually set needle which is used to mark the current measurement so a change can be seen. In addition, the mechanism is made deliberately "stiff" so that tapping the barometer reveals whether the pressure is rising or falling as the pointer moves.

Barographs

A barograph, which records a graph of some atmospheric pressure, uses an aneroid barometer mechanism to move a needle on a smoked foil or to move a pen upon paper, both of which are attached to a drum moved by clockwork.



In-text question

Will you be able to explain to your friend how an aneroid barometer works, if not go back and read the explanation again?

If you are familiar with how the aneroid barometer works then you can study the thermometer next.

A thermometer

A **thermometer** means "warm" and *meter*, "to measure". It is thus a device that measures temperature or temperature gradient using a variety of different principles. A thermometer has two important elements:

- the temperature sensor (e.g. the bulb on a mercury thermometer) in which some physical change occurs with temperature, and
- some means of converting this physical change into a value (e.g. the scale on a mercury thermometer).

The modern thermometers use electronic means to provide a digital display or input to a computer.

How a thermometer works

When you look at a regular outside bulb thermometer, you'll see a thin red or silver line that grows longer when it is hotter. The line goes down in cold weather.

This liquid is sometimes colored alcohol but can also be metallic liquid called mercury. Both mercury and alcohol grow bigger when heated and smaller when cooled. Inside the glass tube of a thermometer, the liquid has no place to go but up when the temperature is hot and down when the temperature is cold.

Numbers are placed alongside the glass tube that mark the temperature when the line is at that point.



Figure 2.3

Calculating average, range and mean temperature



In-text question

Do you know how to calculate average temperature or the range in temperature or possibly the mean temperature? Try to do these before you look at the explanations.

Average

The average is calculated by adding all the data received together and then divide the total by the total number of data sets calculated together, e.g. if you added all the maximum temperatures of January (31 days for the month) then you divide the total by 31. Look at the table below which gives you the temperature for January of Rehoboth.



Temperature and Rainfall for January - Rehoboth

Months	Jan	Feb	March	April	May	June	July	Aug	Sept	Oct	Nov	Dec
Max. Temp. °C	34	32	30	24	20	14	10	22	24	28	34	36
Min. Temp. °C	14	14	12	6	2	0	2	8	12	14	16	18
Rainfall mm	100	120	140	80	40	10	0	0	12	50	85	105

Table 1

Range

To work out the range in temperature do the following:

- take the maximum and minimum readings;
- subtract the minimum reading from the maximum reading e.g.;
- the temperature range for today is:

34 °C (maximum) and 14 °C (minimum)

The range would therefore be 34 °C - 14 °C

That is equal to 20 °C

Mean temperature

Mean Temperature means the average of a series of temperatures taken over a period of time, such as a day or a month. We can be more specific by measuring the daily mean temperature. The mean temperature for a day is determined by averaging the hourly readings or more commonly, by averaging the maximum and minimum temperatures for a day. Now we can look at how to draw temperature graphs.

Drawing temperature graphs

Line Graph

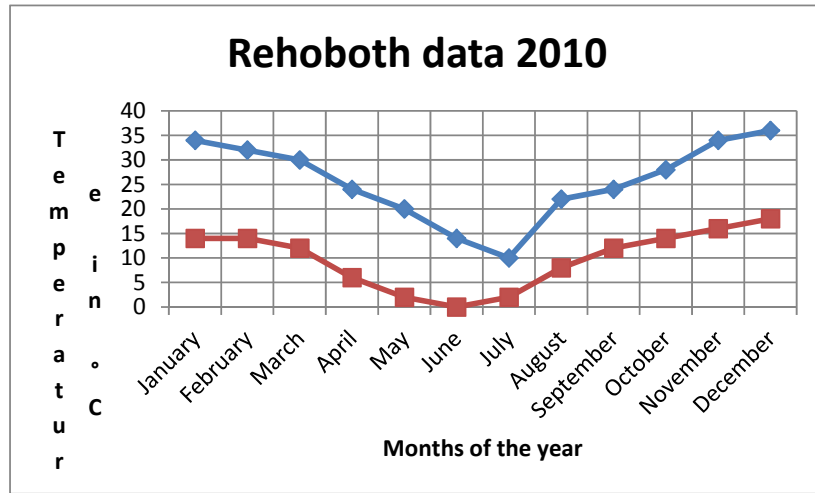

Figure 2.4

Bar graph

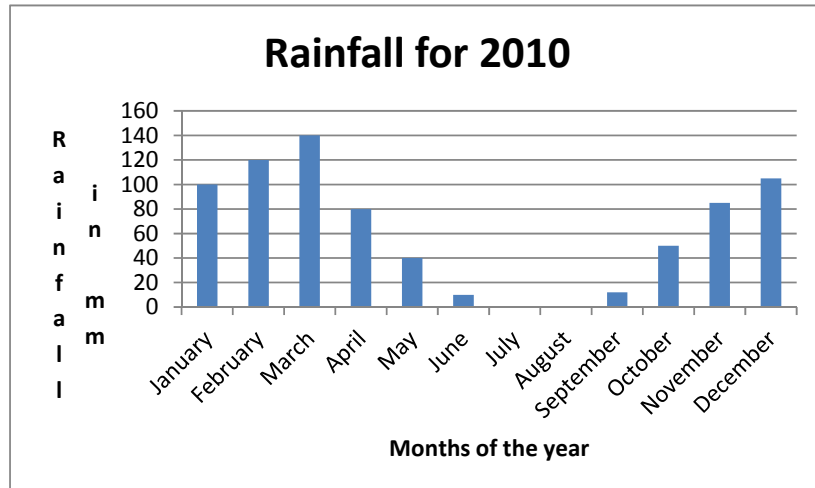

Figure 2.5

Composite graph

Add graph here

Figure 2.6

A rain gauge

A **rain gauge** is an instrument used by meteorologists and hydrologists to measure precipitation in a certain amount of time. It usually measures in millimetres. We can be more specific by saying that one millimetre of measured precipitation is the equivalent of one litre of rainfall per metre squared. I assume that you know by now that precipitation means rainfall.

Now let's explain how a rain gauge looks like. It is usually a tapering funnel of copper or polyester of standard dimension which allows the rain-water to collect in an enclosed bottle or cylinder for successive measurement. The gauge is set in open ground with the funnel rim up to 30 cm above the ground surface. Some gauges are calibrated to allow the amount of rainfall to be read directly. Not all gauges are calibrated, but all you do is calculate the depth of the water in the container and the dimensions of the funnel. You can also pour the water in a measuring jar and then place it on a flat surface. Make sure that when you take the reading that it is situated eye-level to ensure accurate measurement.



In-text question

Can you give short definition to explain a rain gauge? I am sure you will be able to do that.

Below is an example of how a rain gauge looks like.

Rain gauge

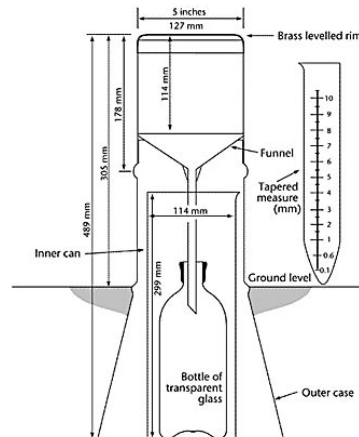

Figure 2.7 Source: <http://www.insidesocal.com/tomhoffarth/archives/2008/07/who-watched-wim.html>

Suns



A **sunshine recorder** is a device that records the amount of sunshine at a given location. The results provide information about the weather and climate of a geographical area. This information is useful in meteorology, science, agriculture, tourism, and other fields.

There are two basic types of sunshine recorders. One type uses the sun itself as a times scale for the sunshine readings. The other type uses some form of clock for the time scale. The common known one is the Campbell Stokes Recorder. Below is an example.

Campbell Stokes Recorder



Figure 2.8

Older recorders required a human observer to interpret the results; recorded results might differ among observers. Modern sunshine recorders use electronics and computers for precise data that do not depend on a human interpreter. Newer recorders can also measure the global and diffuse radiation.



In-text question

We have discussed the aneroid barometer, thermometers, rain gauge and sunshine recorder. Will you be able to explain what an anemometer is to your friend? Give your own definition before you look at the explanation.

Anemometer

This is a typical explanation and I hope you explained it as such. An **anemometer** is a device for measuring wind speed, and it is also a common weather station instrument. Each weather station is supposed to have it. Anemometer is derived from the Greek word anemos, which means wind.

Anemometers can be divided into two classes:

- 1 those that measure the wind's speed, and
- 2 those that measure the wind's pressure;

Seeing that there is a close connection between the pressure and the speed, an anemometer designed in such a way that it gives information about both.

For this course we will look at cup anemometers and windmill anemometers.

Cup anemometers

A simple type of anemometer was invented in 1846 by Dr. John Thomas Romney Robinson, of Armagh Observatory. This anemometer consisted of four hemispherical cups and each one is mounted on one end of four horizontal arms. These arms were mounted at equal angles to each other on a vertical shaft. The air that flow past the cups in any horizontal

direction turned the cups in a manner that was proportional to the wind speed. Therefore, counting the turns of the cups over a set time period produced the average wind speed for a wide range of speeds. On an anemometer with four cups it is easy to see that since the cups are arranged symmetrically on the end of the arms, the wind always has the hollow of one cup presented to it and is blowing on the back of the cup on the opposite end of the cross.

Then there is the three cup anemometer which was developed by the Canadian John Patterson in 1926. Improvements were made by Brevoort & Joiner of the USA in 1935. A cupwheel design was developed which was linear and had an error of less than 3% up to 97 km/h. This three cup anemometer was then further modified by the Australian Derek Weston in 1991 to measure both wind direction and wind speed. Today the three cup anemometers are used as the industry standard for wind resource assessment studies.

Below is an example of an anemometer.

Cup anemometer



Figure 2.9

Windmill anemometers

The windmill type or propeller anemometer is another type. It is called the Robinson anemometer where the axis of rotation is vertical, but with this subdivision the axis of rotation must be parallel to the direction of the wind and therefore horizontal. Furthermore, since the wind varies in direction and the axis has to follow its changes, a wind vane or some other device must be developed to fulfil the same purpose. It is also called an aerovane which has a propeller and a tail on the same axis to obtain accurate and precise wind speed and direction measurements from the same instrument. Below is an example of a windmill style anemometer.

A windmill style of anemometer



Figure 2.10



In-text question

Do you think the wind vane has the same characteristics as a cup anemometer or a windmill anemometer? Give your explanation before you proceed and look at the explanation of the wind vane.

Wind vane

The word 'vane' comes from the Anglo-Saxon word 'fane' meaning 'flag'. A **Wind Vane** is an instrument for showing the direction of the wind. I hope that is what you were thinking off. It is used as an architectural ornament to the highest point of a building. Do you think it served any purpose? Possibly, because it was attractive, like the traditional cockerel design with letters indicating the points of the compass. There were also other motifs like ships, arrows and horses. A wind vane is also known as a weather vane and it is a tool that is used for determining the direction that the wind is blowing.

It is however important for accurate measurement of direction that there is a balance between aerodynamics and weight. The next important factor is the height at which the device is placed. Wind vanes that are located close to the ground might not provide correct readings because of some interference from below like buildings and trees. It is because of that that most wind vanes are placed on top of buildings in order to avoid obstructions and get clean gusts of wind. Below is a typical example of a wind vane.

Wind vane



Figure 2.11



In-text question

Next we are going to discuss the hygrometer. Is it part of the wind or what do you think?

Hygrometer

A **Hygrometer** is an instrument that is used for measuring the moisture content in the environmental air, or humidity. I should mention that it is difficult to measure humidity accurately. Most measurement devices usually rely on measurements of some other quantity such as temperature, pressure, mass or a mechanical or electrical change in a substance as moisture is absorbed. From calculations based on physical principles, or especially by calibration with a reference standard, these measured quantities can lead to a measurement of humidity. A hygrometer actually uses human hair to tell how much humidity is in the air. It contains a sheaf of blond human hairs treated to remove the oils. As the relative humidity increases, the hairs increase in length and operate the recording mechanism.



Hygrometer



Figure 2.12

Source: <http://en.wikipedia.org/wiki/Hygrometer>

Summary of weather instruments

	<p>Barometer: measures atmospheric pressure in Millibars.</p>
	<p>Thermometer: measures the temperature in degrees Celsius or degrees Fahrenheit</p>







	<p>Rain gauge: measures the amount of rainfall in mm. An older version left, new electronic version right</p>
	<p>Campbell Stokes Recorder: measures sunshine. This type of recorder is made up of a glass ball which concentrates sunshine on to a thick piece of card. The sunshine then burns a mark on the card which shows the number of hours of sunshine in the day.</p>
	<p>Anemometer: measures wind speed in mph. The most common type looks like a toy windmill. Three cups are fixed to a central shaft and the stronger the wind blows the faster they spin around. The wind speed is shown on a dial, just like a car's speedometer.</p>
	<p>Wind Vane/Wind Sock: measures wind direction by pointing towards North, East, South or West</p>
	<p>Hygrometer: measures the temperature and amount of humidity in degrees Fahrenheit and degrees Celsius.</p>
	<p>Meteorologists also measure the amount of cloud cover in "oktas" from 1 to 8. 0 oktas means the sky is clear, 8 oktas means the sky is completely covered. The height of a cloud is measured by how far it is above sea level.</p>

Table 1

We have completed the weather instruments and to test your understanding do the next activity.

Activity 1



Activity

Time Required: In this activity you need at most 45 minutes to fully answer the question.

Complete the following table which deals with the weather instruments.



How long?

Instrument	Description	Unit of measurement
	m	illibars/hPa
Thermometer		
	Measure amount of moisture in the atmosphere	
	m	illimeters
Cup anemometer		

Copy the table into your exercise book and complete.

Once done with the activity, please compare your answers with mine before you proceed.



Feedback

Instrument	Description	Unit of measurement
Aneroid barometer	Measure the amount of pressure over a certain area	millibars/hPa
Thermometer	Measure the actual temperature	°C
Hygrometer	Measure amount of moisture in the atmosphere	%
Rain gauge	Measure the amount of rainfall in a given time	millimeters
Cup anemometer	Measure the speed and direction of wind	kph

I guess you found it fairly easy to do. Next we will look at section 2 which deals with climatic maps.

Section 2

Climatic maps

Now that you have studied and understood the three basic elements of climate and weather (temperature, rainfall and wind), you are almost ready to present your data (which you recorded through the weather instruments) by means of temperature, rainfall and air pressure maps. In this section we are briefly going to discuss how to draw these three types of maps. As with the previous sections I want you to look at the section outcomes first.

Upon completion of this section you should be able to:



Section outcomes

- interpolate by using isolines
- know the difference between isotherms, isohyets and isobars.

Namibia weather map

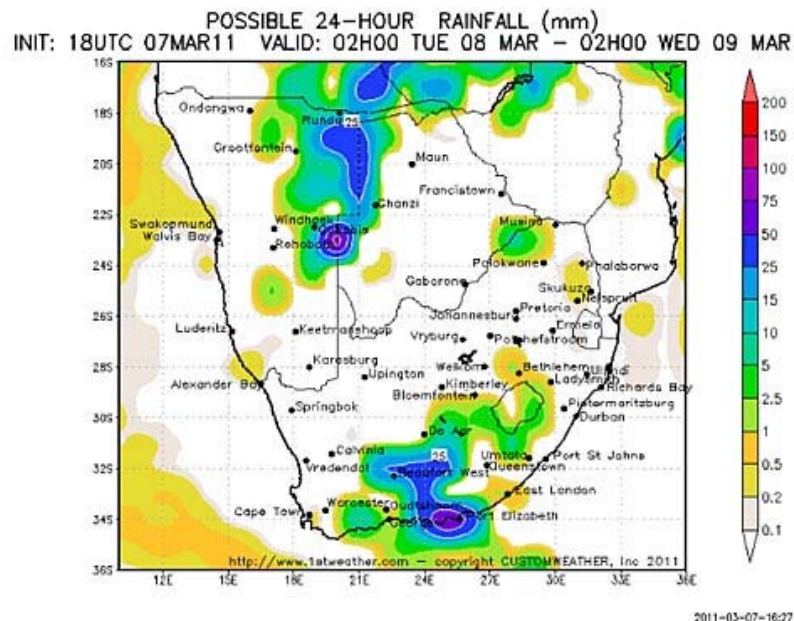

Figure 2.13

Source: <http://www.republikein.com.na/images/reenkaart8-3.jpg>

Data recording

Interpolate by using isolines

Explain the different ways to record and present data.



Difference between

Isotherms

A line connecting points of equal temperature is called an **isotherm**. That means, at every point along a given isotherm, the values of temperature are the same.

Isohyets

A line drawn on a map connecting points that receive equal amounts of rainfall. Figure 2.13 shows a rainfall map.

Isobars

Isobars are lines of equal atmospheric pressure drawn on a meteorological map. Each line passes through a pressure of a given value, provided certain rules are followed. The rules for drawing isobars are-

1. Isobar lines may never cross or touch.
2. Isobar lines may only pass through pressures of 1000 + or - 4. In other words, allowable lines are 992, 996, 1000, 1004, 1008, and so on.
3. The atmospheric pressure is given in millibars (mb). One millibar = 0.02953 inches of mercury.
4. Pressure lines are usually corrected for sea level so any differences in pressure due to altitude are ignored.



In-text question

Will you be able to identify different types of isolines on maps? Look at different maps to see if you can differentiate between isolines.



Activity

Activity 2

Time Required: In this activity you need at most 45 minutes to fully answer the question.



How long?

ADD ACTIVITY PLEASE

Once done with the activity, please compare your answers with mine before you proceed.



Feedback

Section 3

Air pressure systems

Air pressure systems are not an unfamiliar term to you, but don't worry we will explain it to you again. In this section we will not only explain high and low pressure systems and how they are involved in air movement, but also their effects on the weather.

Upon completion of this section you should be able to:

- *identify* high and low pressure systems;
- *understand* the relationship between pressure systems and the movement of air;
- *describe* high and low pressure systems and identify them on a map;
- *describe* the weather associated with high and low pressure systems;
- *draw* sketches representing vertical and horizontal air movements in relation to high and low pressure systems.

You have already learnt about atmospheric pressure in Sections 2 and 3. Complete the following quiz to refresh your memory.

Match the descriptions in column A with the correct terms in column B:

Column A	Column B
The unit of measurement of	Atmospheric pressure

atmospheric pressure	
The force with which the air presses down on the earth.	Isobars
Atmospheric pressure at sea-level	Millibars or hectopascal
The lines connecting places with the same atmospheric pressure	1013mb

How well did you do?

Before we continue, we need to find out how pressure cells are created. When points with the same air pressure are joined with isobars, pressure cells are formed. Pressure cells may have a circular or oval shape and may either be high or low.

But how do we distinguish between high and low pressure cells? Look at the two pressure cells below and then see if you can match the descriptions below to the correct pressure cell.

- isobar values decrease towards the centre of the cell
- isobar values increase towards the centre of the cell
- air spirals anti-clockwise
- air spirals clock wise

High pressure cell

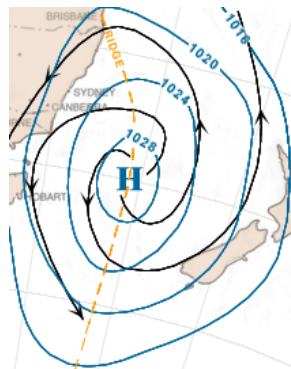

Figure 2.14 (a)

Low pressure cell

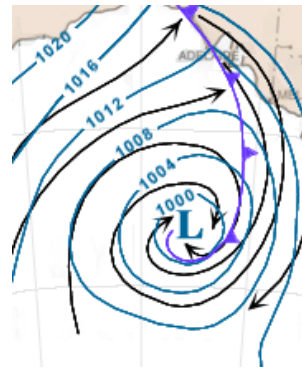

Figure 2.14 (b)

When two high pressure cells join, a ridge of high pressure is formed.

When two low pressure cells join, a trough of low pressure is formed.

(Insert sketches)

Pressure cells also give us an indication of how fast the wind moves in a pressure cell: The closer the isobars are to each other, the stronger the wind and vice versa.

How does air move between high and low pressure cells?

Air can rotate parallel to the isobars as shown in the pressure cells above. This is called geostrophic flow. But due to the Coriolis force (see below)

air is deflected to the left in the Southern Hemisphere. This will cause air to move across isobars as shown below. (Add arrows that move across the isobars.)

When a high and a low pressure cell are close to each other air will then start to move from the high pressure cell to the low pressure cell as wind. Look at the illustration below:

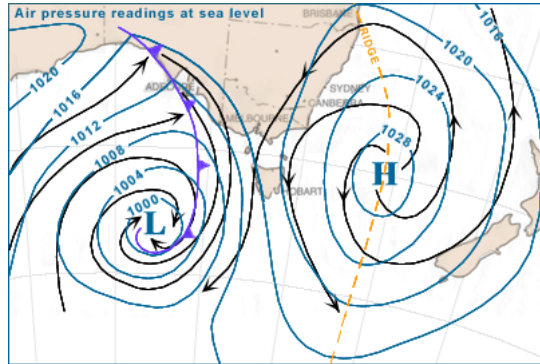

Figure 2.15

Air spirals anti-clockwise and outwards from the high pressure cell to the low pressure cell where it spirals clockwise and inwards.

(Add arrows)

The illustration below shows the following:

- the balls show how air descends in a high pressure cell and ascends in a low pressure cell
- the arrows show how air spirals ant-clockwise in a high pressure cell and clockwise in a low pressure cell
- Note that the air moves out of the high pressure cell into the low pressure cell.

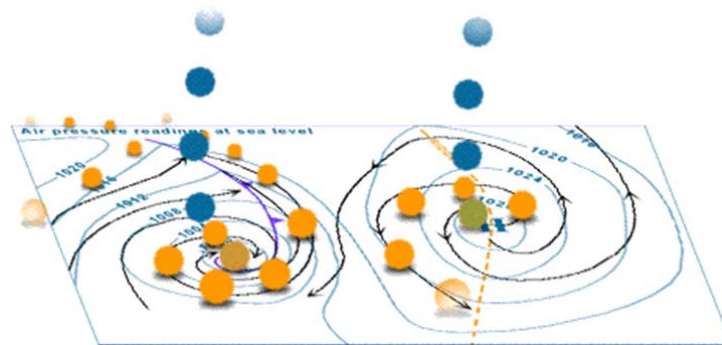

Figure 2.16

What is the Coriolis force?

Coriolis force occurs due to the rotation of the earth on its own axis. The earth rotates from west to east and this causes objects in the Southern Hemisphere to be deflected towards the left and objects in the Northern Hemisphere to be deflected towards the right. This means that if a wind blows directly at you from the back, you will most likely be pushed to the left in the southern hemisphere and to the right in the northern hemisphere. (Insert illustrating diagram)

(Add illustration)

Low pressure cells:

When air temperatures increase, it expands because air molecules are moving further away from each other. Warm air starts to rise because it is light and less dense. As air rises (remember that air in a low pressure cell spirals clockwise) it starts to cool down because the upper atmosphere is colder. If the air contains enough water vapour and reaches dewpoint temperature, condensation will take place. Clouds are formed and it may result in rain formation. So low pressure cells are associated with cloud cover and possible rain. Refer back to 'Terminologies' to refresh your memory for the words printed in italics.

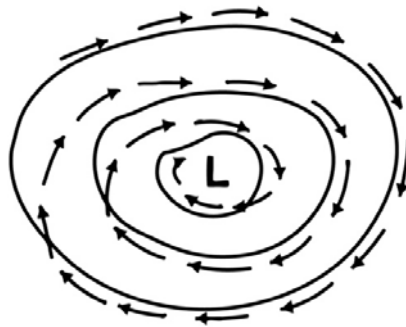

Figure 2.17

High pressure cells

When temperatures decrease, it contracts because air molecules are moving closer to each other. Cold air will start to descend (remember that air in a high pressure cell spirals anti-clockwise!) because it is heavier and more dense. As the cold air descends, it starts to warm up. As it now comes in contact with warmer temperatures, air may lose moisture and become dry. This means that no condensation and cloud formation will take place. High pressure cells are thus associated with clear skies.

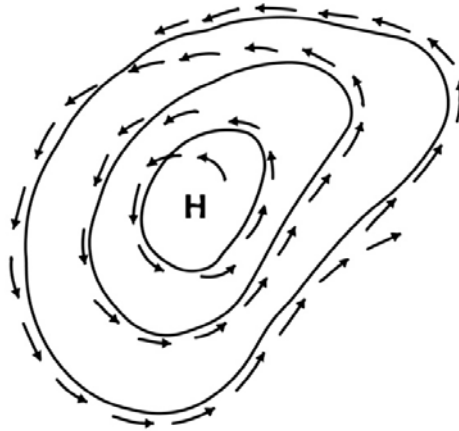

Figure 2.18

Can you tell by which type of pressure cells are the interior of Namibia dominated during summer and winter? Think of when Namibia receives rainfall and when it is dry.

During summer:

Warm, moist air from the equator moves further southwards and extends into the north-eastern parts of our country. Temperatures rise and warm air ascends. Low pressure cells are dominating over the country and pushes high pressure cells further southwards.

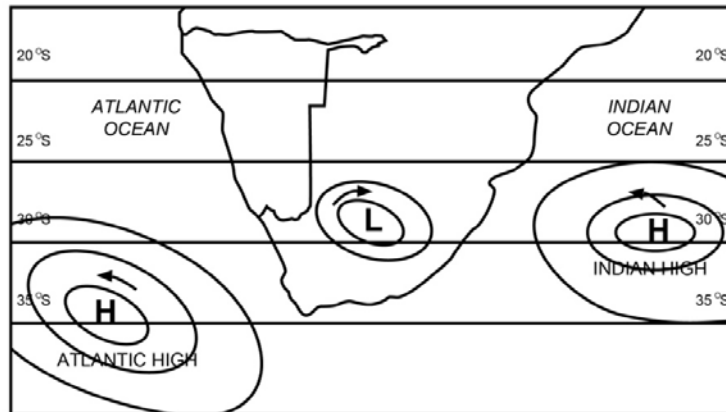

Figure 2.19

During winter:

Cold air from the South Pole extends further northwards into Southern Africa. Colder air descends and loses moisture, meaning no condensation, resulting in clear skies. So during winter our climate is dominated by high pressure cells.)

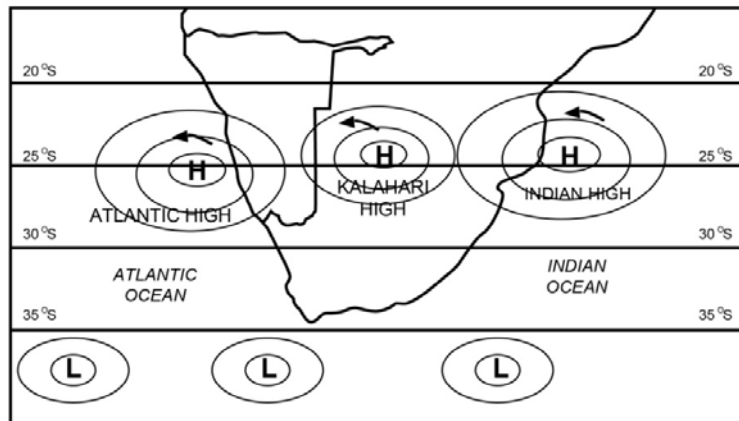

Figure 2.20

Next we will do activity 3 to test your understanding.

Activity 3



Activity



How long?

Time Required: In this activity you need at most 45 minutes to fully answer the question.

Say whether the following statements are true or false:

1. Cold air is heavier and denser than warm air.
2. Warm air rises in a high pressure cell.
3. Air in a low pressure cell spirals in a clockwise direction in the Southern hemisphere.
4. High pressure cells are associated with clear skies.
5. During winter the interior of Namibia is dominated by low pressure cells.
6. Strong winds are caused by a steep gradient between pressure cells.
7. Coriolis force is the movement of air parallel to the isobars of a pressure cell.
8. Geostrophic flow causes air to move across the isobars of a pressure cell.

Once done with the activity, please compare your answers with mine before you proceed.



Feedback

1. True
2. False. Warm air rises in a low pressure cell.
3. True.
4. True.
5. False. High pressure cells dominate the Namibia's interior during winter.
6. True.
7. False. Geostrophic flow is the movement of air parallel to the isobars of a pressure cell.
8. False. Coriolis force causes air to move across the isobars of a pressure cell.

Let us see if we can identify high and low pressure cells on synoptic weather maps and also describe and explain the type of weather associated with each, in the next section.

Section 4

Synoptic weather maps



Section outcomes

Synoptic weather maps

Upon completion of this section you should be able to:

- Interpret synoptic weather maps by:
 - *describing* weather conditions as shown by synoptic symbols;
 - *describing and explaining* the type of weather associated with high and low pressure cells.

What is a synoptic weather map?

A synoptic weather map is a chart that gives us information about the weather experienced in a certain area for a specific time. Metereologists can also use this information to forecast or predict the weather for the next few days.

Information is given by means of a weather station model, which is a small circle representing a specific town or city. You read it as follows:



Wind speed: 15 knots (long feather = 10 knots and the short feather = 5knots)

Maximum temperature in °C

24

north-east

precipitation (see table)

11

Dewpoint temperature in °C

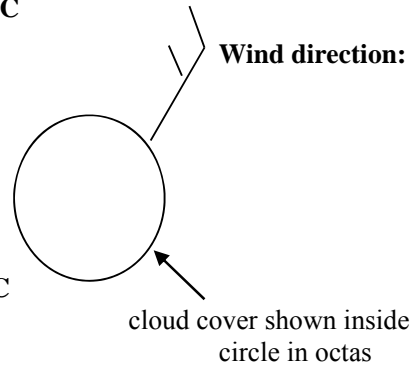

Figure 2.21

The table below shows the different types of precipitation and cloud cover that may be experienced:

	1 octa 	2 octas 	3 octas 	4 octas 	<ul style="list-style-type: none"> • rain △ hail ☉ drizzle = fog * snow ⚡ thunder-storm ▽ showers
clear	1/8 cloud	2/8 cloud 25%	3/8 cloud	4/8 cloud 50%	
	5 octa 	6 octas 	7 octas 	8 octas 	
5/8 cloud	6/8 cloud 75%	7/8 cloud	overcast 100%	poor visibility e.g. smoke	

Table 2

Let us now test your understanding of synoptic weather maps below:

Activity 4



Activity

Time Required: In this activity you need at most 45 minutes to fully answer the question.



How long?

1. Draw a weather symbol which indicates the following weather conditions:

Maximum temperature: 27°C

Dewpoint temperature: 11°C

Cloud cover: 2 octas

Wind direction: South-west

Wind speed: 10 knots

2. Study the synoptic weather map below and answer the questions that follow.

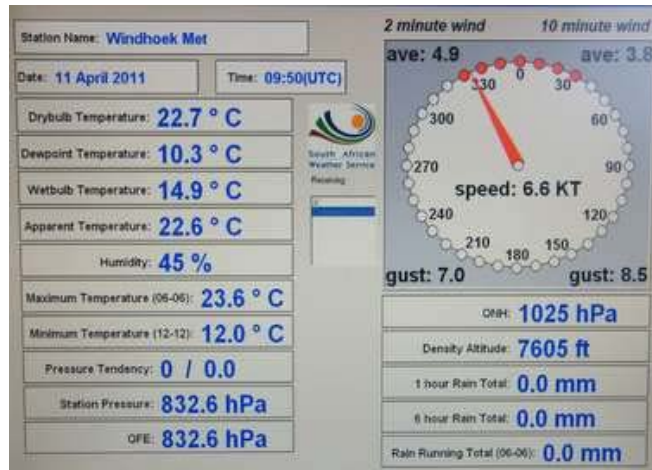

Once done with the activity, please compare your answers with mine before you proceed.



Feedback



Section 5

Micro climates



Section outcomes

Do you know what micro climates are? Don't worry we will explain everything to you in this section.

Upon completion of this section you should be able to:

- describe micro climates below and explain their influence on local climate
 - land and sea breezes
 - valley and mountain breezes
 - berg winds

What are micro climates?

Do you know what the word 'micro' means? Yes, it means 'small'. So put 'small' and 'climate' together and it means 'climates affecting a small area'. They are also referred to as 'local' climates, because people living in an area get used to that type of climate and then associate that type of climate with the area.

Namibia experiences three types of micro-climates:

- land and sea breezes
- valley and mountain breezes
- berg winds, also called 'east winds'

Let us look at each of the micro-climates in detail:

Land and sea breezes

Before we continue, there are two basic things that you must understand. We have dealt with them before:

Do you remember that in Section 1, we mentioned that a wind is named after the direction from where it comes? So where does a land breeze blow from? And a sea breeze? Yes a land breeze blows from the land and a sea breeze blows from the sea.

Now can you remember that we mentioned that we also mentioned that air moves from an area of high pressure to an area of low pressure? Good! So if a land breeze blows from the land, it means that a high pressure has developed over land and a low pressure has developed over the sea. And if a sea breeze blows from the sea, it means that a high pressure has developed over the sea and a low pressure over the land.

Now we need to look at the conditions that cause high pressure to develop over land and sea:

During the day land warms up faster than the ocean. There are two reasons why the ocean takes longer to warm up:

- Water is transparent and allows the rays of the sun to penetrate deeper, meaning that the heat is spread to deeper areas and over land it is only the upper layers of soil that are warmed up.

Land and sea breezes are micro climates which occur along the coast.

- Water is in continuous motion, meaning the heat is spread over a larger area than over land.

As the land warms up, a low pressure develops because warm air is less dense and starts to rise. A high pressure develops over the ocean because the air is colder and denser. Air then starts to move from a high pressure cell to a low pressure cell, in other words from sea to land. This is called a sea breeze.

A sea breeze

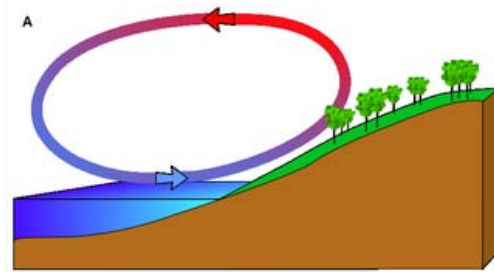

Figure 2.22
Source: Wikipedia

A land breeze occurs during the night when land cools down faster than sea because water retains its heat for longer than land. Warmer air over the sea starts to rise, forming a low pressure cell. The colder air over land starts to sink, creating a high pressure cell. Now air starts to move from a high to a low pressure cell, in other words from land to sea. This is called a land breeze.

A land breeze

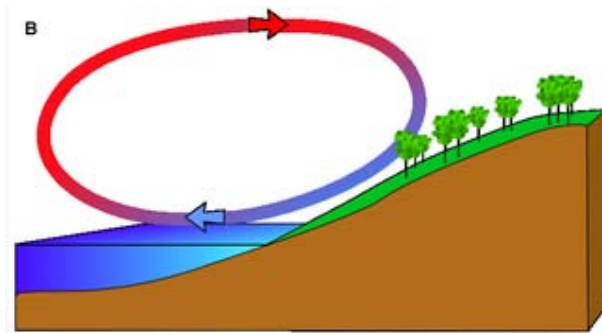

Figure 2.23
Source: Wikipedia

Valley and mountain breezes

Once again, we are going to look at where air warms faster during the day and during night:

During the day mountain slopes receive more sunlight than the valley floor. This means that air on the mountain slopes warms up faster than air in the valley. Warm air then rises up the mountain slopes, pulling air on

Valley and mountain breezes are micro climates that occur in mountainous areas.

the valley floor upwards. This is called a valley breeze, because air moves from the valley floor up to the top of the mountain.

A valley breeze

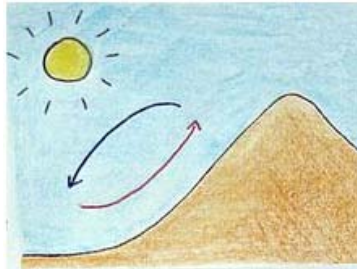

Figure 2.24

Source: *Wikipedia*

At night, the heat on the mountain top escapes faster than the heat on the valley floor. The mountain tops are higher above sea level than the valley floor and as height increases, temperatures drop. Now cold air starts to flow down the mountain sides because it is heavier and denser. This is called a mountain breeze, because air moves from the mountain top to the valley floor.

A mountain breeze



Figure 2.25

Source: *Wikipedia*

A mountain breeze can cause very cold conditions in a valley. This could happen when the descending cold air pushes under the warmer air in the valley. Because cold air is dense and heavy, it will not rise and remain trapped under the warm air. This is called an ‘inversion layer’.

Berg winds (east winds)

During winter, a high pressure cell is formed over the interior of Namibia, by cold, dense air sinking to the earth. A low pressure develops along the coast due to warmer temperatures which cause air to rise. Air then moves from the high pressure cell to the low pressure cell, in other words from the interior of the country to the coast. But we must remember that as air moves from inland to the coast it warms up because it flows from a higher to a lower altitude. As wind blows towards the coast it crosses the Namib Desert where it picks up much sand and further

Berg winds originate inland and then travel towards the coast where they are experienced as hot and sandy winds.

warms up. When east winds reach the coast they are hot and sandy, which is very unpleasant.

A berg wind

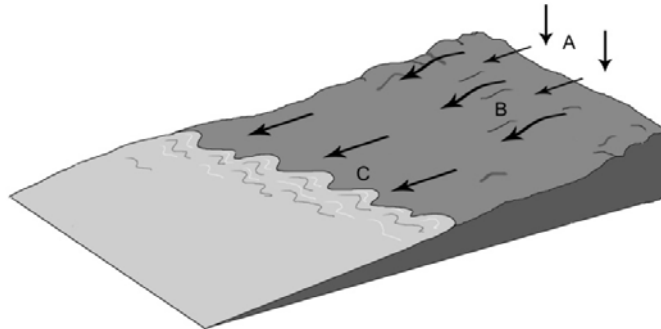

Figure 2.6

Test yourself by answering the following questions:

Activity 4



Time Required: In this activity you need at most 45 minutes to fully answer the question.

Activity



How long?

1. Add descriptions to each of the letters in the diagram to show the formation of a land breeze.

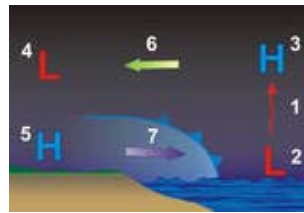

2. Diagrams A and B below represents different micro-climates.

- (a) State the micro-climate shown by each of A and B. [2]
- (b) Explain how these winds are formed. [2x4]

A

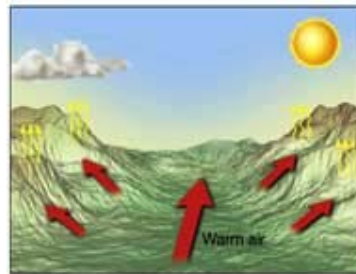

B

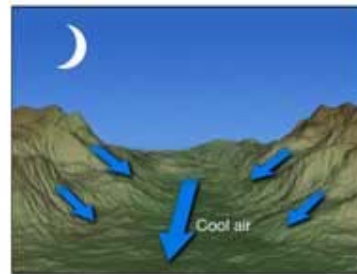

Once done with the activity, please compare your answers with mine before you proceed.



Feedback

1. Air over the sea is warmer than air over land.
2. Warm air over the sea starts to rise creating a low pressure.
3. Rising air cools down.
4. Cold air over land starts to descend in the high pressure cell (5).
5. Air starts to move from an area of high pressure to an area of low pressure, from land to sea.

2. (a) A – valley breeze, B – mountain breeze

(b) A - During the day mountain slopes receive more sunlight than the valley floor. This means that air on the mountain slopes warms up faster than air in the valley. Warm air then rises up the mountain slopes, pulling air on the valley floor upwards.

B - At night, the heat on the mountain top escapes faster than the heat on the valley floor. The mountain tops are higher above sea level than the valley floor and as height increases, temperatures drop. Now cold air starts to flow down the mountain sides because it is heavier and denser.

References



References

<http://en.wikipedia.org/wiki/Barometer>

<http://en.wikipedia.org/wiki/Thermometer>

http://www.energyquest.ca.gov/how_it_works/thermometer.html

http://simple.wikipedia.org/wiki/Rain_gauge

http://en.wikipedia.org/wiki/Weather_vane

<http://www.wisegeek.com/what-is-a-wind-vane.htm>

<http://en.wikipedia.org/wiki/Hygrometer>

<http://www.republikein.com.na/images/reenkaart8-3.jpg>

http://en.wikipedia.org/wiki/Sunshine_recorder

<http://www.insidesocal.com/tomhoffarth/archives/2008/07/who-watched-wim.html>

<http://en.wikipedia.org/wiki/Anemometer>

<http://inbythroughhim.blogspot.com/2009/05/wind-blows-where-it-wants-to.html>

<http://www.republikein.com.na/images/reenkaart8-3.jpg>



Unit summary



Summary

In this unit you learned Meteorologists use a variety of instruments to measure the weather to give an accurate reading of what the weather is like.

A **barometer** is a scientific instrument used in meteorology to measure atmospheric pressure

A **barograph**, which records a graph of some atmospheric pressure, uses an aneroid barometer mechanism to move a needle on a smoked foil or to move a pen upon paper, both of which are attached to a drum moved by clockwork.

A **thermometer** means "warm" and *meter*, "to measure". It is thus a device that measures temperature or temperature gradient using a variety of different principles.

The average is calculated by adding all the data received together and then divide the total by the total number of data sets calculated together, e.g. if you added all the maximum temperatures of January (31 days for the month) then you divide the total by 31.

A **rain gauge** is an instrument used by meteorologists and hydrologists to measure precipitation in a certain amount of time. It usually measures in millimetres.

A **sunshine recorder** is a device that records the amount of sunshine at a given location.

An **anemometer** is a device for measuring wind speed, and it is also a common weather station instrument.

A **Wind Vane** is an instrument for showing the direction of the wind.

A **Hygrometer** is an instrument that is used for measuring the moisture content in the environmental air, or humidity.

Isotherms are lines connecting points of equal temperature is called an isotherm. That means, at every point along a given isotherm, the values of temperature are the same?

Isohyets are lines drawn on a map connecting points that receive equal amounts of rainfall

Isobars are lines of equal atmospheric pressure drawn on a meteorological map. Each line passes through a pressure of a given value, provided certain rules are followed

Air can rotate parallel to the isobars and this is called **geostrophic flow**. But due to the Coriolis force air is deflected to the left in the Southern Hemisphere. When a high and a low pressure cell are close to each other air will then start to move from the high pressure cell to the low pressure cell as wind. Air spirals anti-clockwise and outwards from the high pressure cell to the low pressure cell where it spirals clockwise and

inwards.

Coriolis force occurs due to the rotation of the earth on its own axis. The earth rotates from west to east and this causes objects in the Southern Hemisphere to be deflected towards the left and objects in the Northern Hemisphere to be deflected towards the right.

When air temperatures increase, it expands because air molecules are moving further away from each other. Warm air starts to rise because it is light and less dense.

A **synoptic weather map** is a chart that gives us information about the weather experienced in a certain area for a specific time. Meteorologists can also use this information to forecast or predict the weather for the next few days.

Information is given by means of a weather station model, which is a small circle representing a specific town or city.

Micro climates? means 'small'. So put 'small' and 'climate' together and it means 'climates affecting a small area'. They are also referred to as 'local' climates, because people living in an area get used to that type of climate and then associate that type of climate with the area.

- land and sea breezes
- valley and mountain breezes
- berg winds, also called 'east winds'

So if a land breeze blows from the land, it means that a high pressure has developed over land and a low pressure has developed over the sea. And if a sea breeze blows from the sea, it means that a high pressure has developed over the sea and a low pressure over the land.

Assessment



Assessment

QUESTION 1

Study instruments A and B below and answer the questions.



A.

B.

Identify instruments A and B. (2)

(ii) What aspects of weather is measured with instrument A and give the unit of measurement? (2)

(iii) What alternative measurement technique can be used for wind speed when the anemometer is not available? (1)

(iv) Briefly describe how instrument B works. (5)

(b) Use the table below and draw a wind rose with the information given. (5)

Direction of wind	N	NE	E	SE	S	SW	W	NW	Caln
Number of days	6	5	4	2	2	2	3	1	5

Figure 2.19

(15)

QUESTION 2

(a) The diagrams below show two different pressure systems. Study it and answer the questions.

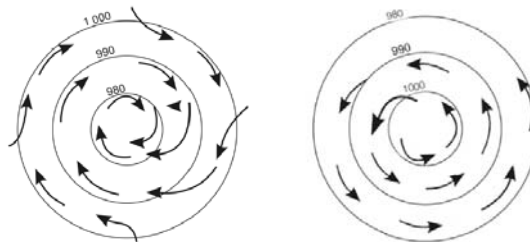

A

B

(i) Identify the pressure system A and B. (2)

(ii) Briefly describe the development of these pressure systems.

(4+4)

Describe the weather associated with these systems respectively and give alternative names to the systems. (5)

(15)

QUESTION 3

Draw the following weather symbols.

- (i) cloud cover: -clear
-1 octa
-poor visibility

- (ii) precipitation: -drizzle
-fog
-snow
-thunderstorm
-showers

- (iii) fronts: -cold front
-warm front (2)

Study the synoptic weather map below and answer the questions.

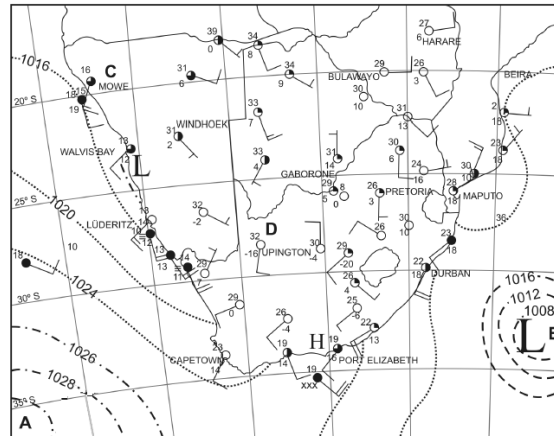

- (i) Identify the pressure system at A. (1)
- (ii) Give a reason why the map shows summer or winter conditions. (2)
- (iii) What is the wind direction and wind speed at Windhoek? (2)

[15]

QUESTION 4

(a) Study the cross-section of Namibia below and answer the questions.

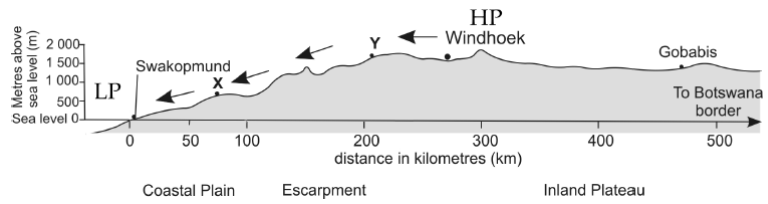

- (i) Calculate the temperature of Arandis (600m) if the temperature at Gobabis (1400m above sea level) is 19 degree Celsius. (4)
- (ii) What are the east winds called? (1)

The diagrams below show two breezes.

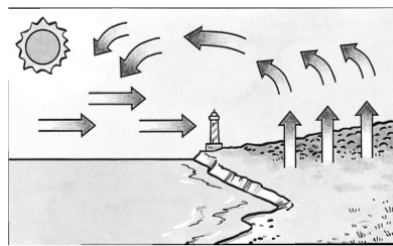

A

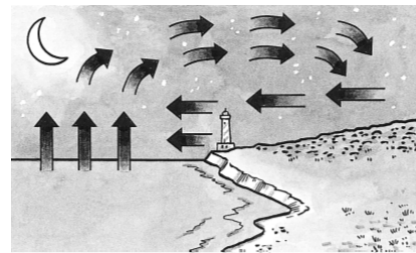

B

- (i) Identify these two breezes in A and B. (2)
- (ii) Briefly describe how these two breezes occur. (4+4)

[15]

Assessment Feedback



Assessment

ASSESSMENT FEED BACK OF UNIT 2 – CLIMATOLOGY

QUESTION 1

(a) (i) A – anemometer (cup)

B – sunshine recorder

(ii) wind speed in knots, km/h or meters per second

(iii) Beaufort scale

(iv) – it consists of a solid glass ball that acts as a lens.

- the lens concentrates the rays of the sun onto a piece of card which is marked off in hours.

- as the sun moves from sunrise to sunset, a line is burnt onto the card.

- at the end of the day the number of hours can be counted from the card.

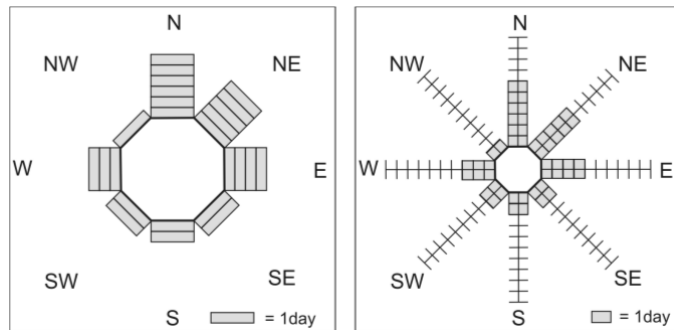

(b)

QUESTION 2

(a) (i) C – low pressure

D – high pressure

(ii) C – when air is heated, it becomes less dense and it starts to rise.

-the rising air starts a clockwise spiralling movement, causing the air to move from the outside to the inside.

- as the air rises it will start to cool down.

-condensation will take place, resulting in cloud formation.

D – When air rises it starts to cool down.

-cool air becomes denser and heavier and is forced aside.

-the cold sinking air is pressing down on the surface and causes pressure to rise.

-this descending air starts an anti-clockwise spiralling movement, causing the air to move from the inside to the outside.

(b) low pressure(cyclones or depressions) = clouds and rain

high pressure(anti-cyclone) = clear skies and no rain

QUESTION 3

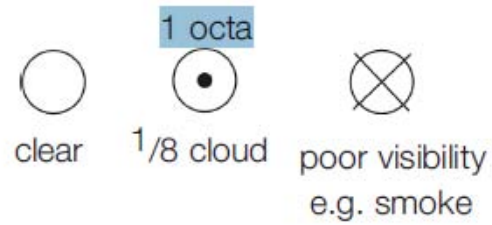

(a) (i)

(ii)

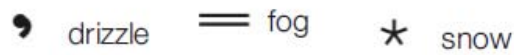

(iii) A is a warm front, b a cold front



(b) (i) X- high pressure

(ii) winter - low temperatures , clear skies

(iii) south east; 5 knots

QUESTION 4

$$(a) (i) \frac{1400\text{m} - 600\text{m}}{100} = \frac{800\text{m}}{100} = 8$$

$$19 + 8 = 27$$

The temperature at Arandis is 27°C

(ii) Bergwinds

(b) (i) A- land breeze

B- sea breeze

(ii)A - LAND BREEZE: - during the night the ocean cools down more slowly than the land. The temperature of the air above the ocean also remains warmer than the air above the land. The higher ocean temperature leads to a low pressure system forming over the ocean which causes the air to rise over the ocean. Colder, denser air flows in from the land to the ocean.

B – SEA BREEZE: during the day the ocean heats up more slowly than the adjacent land, because water is transparent. This leads to heat spreading over a larger area and therefore lower temperatures. The air above the land heats up faster than air above the ocean, resulting in higher temperatures on land than on the ocean. These higher land temperatures cause a low pressure system to form and this causes the air over the land to rise. Colder, denser air flows in from the ocean to the land.

Assignment 1



Assignment

SECTION A

MAPWORK

Question 1

(a) Study the contour map of an island (Fig. 1) and answer the questions that follow:

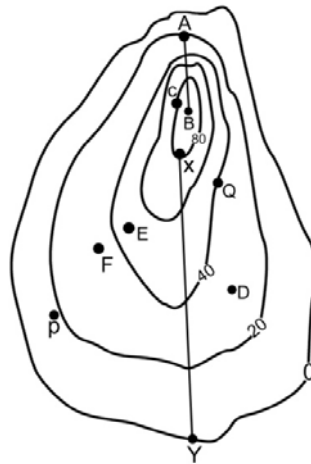

Map reading for Southern Africa Fig. 1

(i) What is the height of this island at its highest point? [1]

(ii) What is the vertical interval of the contour lines? [1]

(iii) Point P is 20m high and point Q is 40m high. How high are the following?

D _____ E _____ F _____ [3]

(iv) Choose the correct answer (by underlining the correct word in brackets) and state why you have chosen it:

1. Slope A – B is (gentle, steep) because _____ [2]

2. Slope X – Y is (gentle, steep) because _____ [2]

(v) What is the height of the unnumbered contour line? _____ [1]

(b) Fig. 2 shows an incomplete contour map.

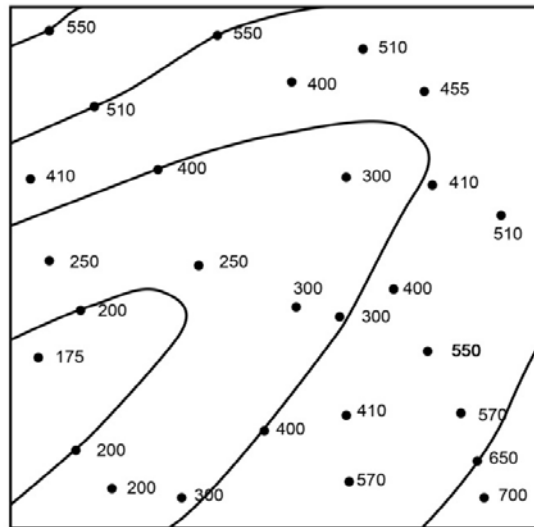

Map reading for Southern Africa Fig. 2

(i) On Fig. 2, shade the area lower than 200m. [1]

(ii) Complete Fig. 2 by adding the 300m and 500m contour lines. [2]

(iii) Identify the landform shown by the completed contour map. [1]

(c) Fig. 3B shows a half drawn cross-section from point X to point Y on Fig. 3A.

Follow the instructions in your textbook to complete the cross-section XY.

You must work accurately!

[4]

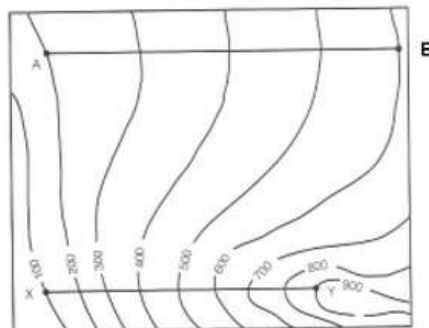

Map reading for Southern Africa
Fig. 3A

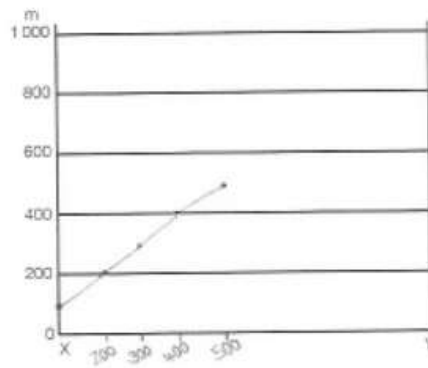

Fig. 3B

(d) Study Fig. 4 and answer the questions that follow.

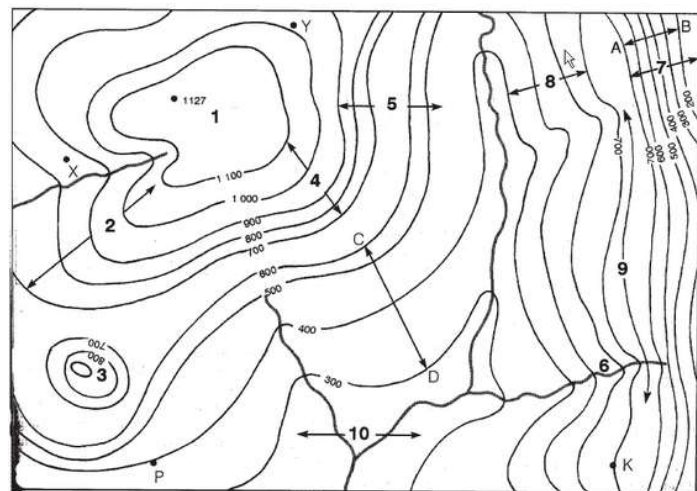

Fig. 4
Map reading for Southern Africa

(i) Identify the following landforms on the map: [4]

- 1 _____
 3 _____
 6 _____
 9 _____

(ii) Identify the following slopes on the map: [4]

- 2 _____
 4 _____
 5 _____
 7 _____

(iii) State if the following are visible:

X from Y _____ P from K _____
 [2]

(iv) There is another valley on one of the river banks of the main river, where a tributary could flow. Clearly mark the probable course of a river in this valley on the map.



Also indicate its direction of flow with an arrow. [2]

Question 2

Fig. 5 shows an extract of a topographical map.

Use the map references in your textbook to answer the questions.

(a) Convert the ratio scale of the map into word scale. [1]

(b) What symbol is used to show the height of BPP 96? [1]

(c) Identify two types of services found in Kasane. [2]

(d) Identify two types of recreational facilities shown in the mapped area. [2]

(e) What is the direction from Sidudu Game Scout Camp to Sidudu island? [1]

(f) Calculate the following approximate bearings:

1. from BPP 96 to Commissioner's Kop _____ [1]

2. from the fire tower to the school in Kasane _____ [1]

(g) Calculate the length of the airstrip at Kasane. Give your answer in metres. [1]

(h) Write down the six-figure grid references of the following feature:

the fire tower _____ [2]

(i) Identify the feature found at the following grid reference:

$03^{\circ} 01'35''S$; $80^{\circ} 26'20''E$ _____ [1]

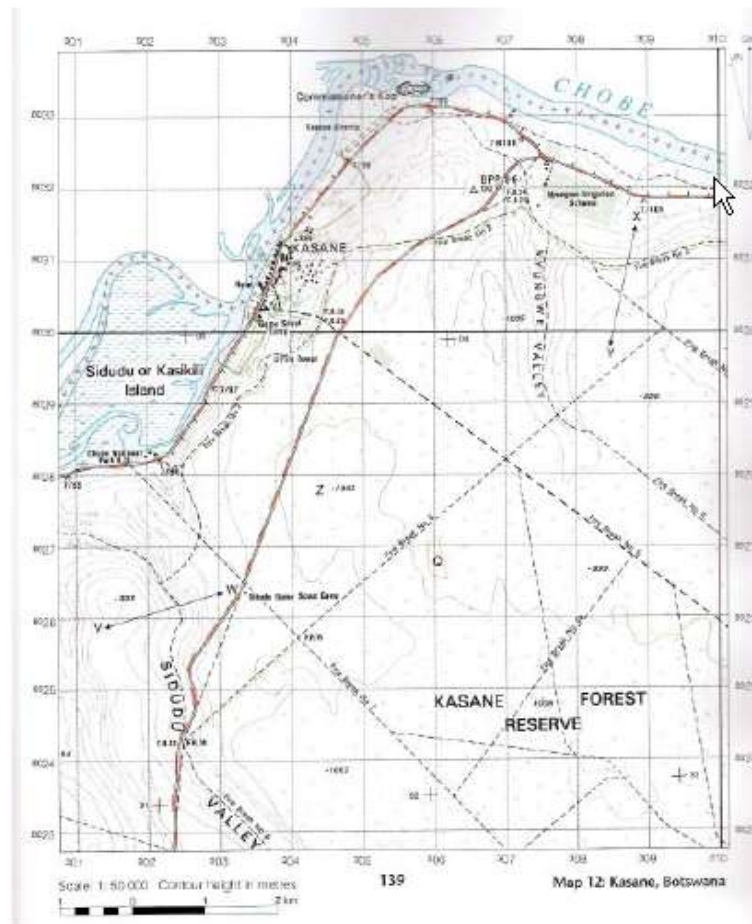

Fig.5

Fig. 6 shows a specific type of photograph.



Fig. 6

Fig. 6

(a) Identify the type of photograph shown in Fig. 6. [1]

(b) Does the photograph show a rural or urban area? [1]

(c) Give one reason for your answer in (ii). [1]

(d) Suggest two advantages of this type of photograph. [2]

(e) Describe two disadvantages of this type of photograph.

[2]

Total Marks for Section A: [50]

SECTION B

CLIMATOLOGY

Question 4

a) Fig. 7 shows four weather graphs that were drawn from information obtained at a school weather station over 7 days.

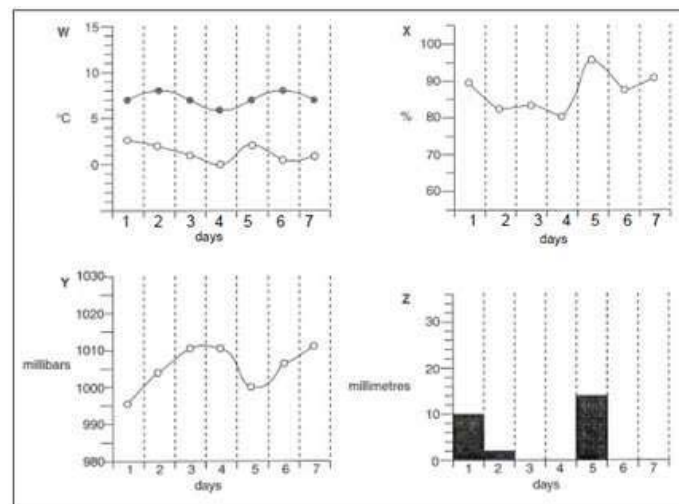

Fig. 7

CIE 2002

(i) Name the weather instruments used to collect the data shown on graphs W, X and Y.

W _____
 X _____
 Y _____ [3]

(ii) Use the graphs to find the following data:

1. the daily range of temperature on day 2

2. the air pressure on day 7 _____
3. the rainfall on day 5 _____
4. the relative humidity on day 4
 _____ [4]

(b) The instrument below was used to obtain the data for graph Z.

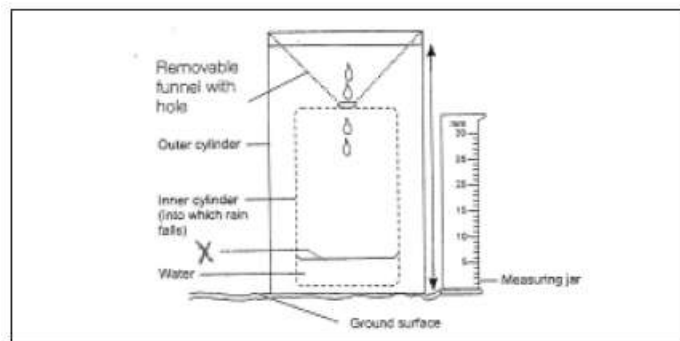

Fig. 8

Namcol JSC

(i) Identify the instrument in Fig. 8. _____
 [1]

(ii) Do the following on Fig. 8:

A - Add the correct label for X. [1]

B - Indicate the correct height above the ground surface at which the rim of the instrument must be. [1]

(iii) Give a reason why the rim must be at the height that you have shown on Fig. 8. [1]

(iv) Explain how one should ensure that the readings from the instrument in Fig. 8 are taken accurately. [3]

(c) Fig. 9 shows four possible locations (P, Q, R and S) for the instrument which measures rainfall at a school weather station.

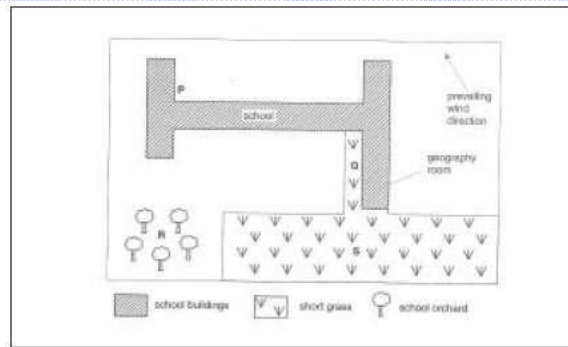

CIE 2002

Fig. 9

(i) Which of the sites, giving a reason for your answer, would you choose to site the weather instrument? [2]

(ii) Give reasons why you rejected each of the other locations. [3]

(d) Fig.10 shows the instrument used to obtain the weather data shown in graph X.

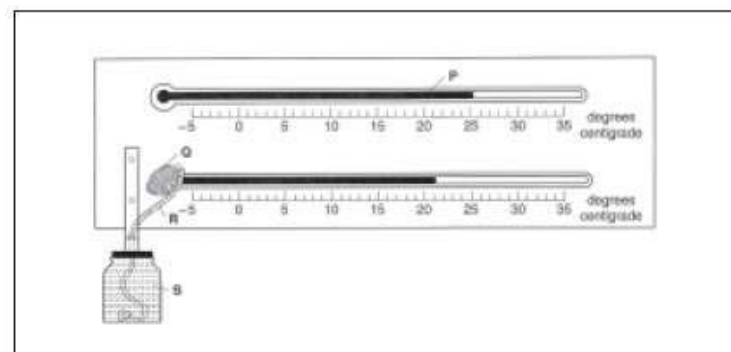

CIE 2005

Fig. 10

(i) Write down the correct labels for P, Q, R and S. [4]

- P _____
- Q _____
- R _____
- S _____

(e) Fig. 11 shows two weather instruments, A and B.

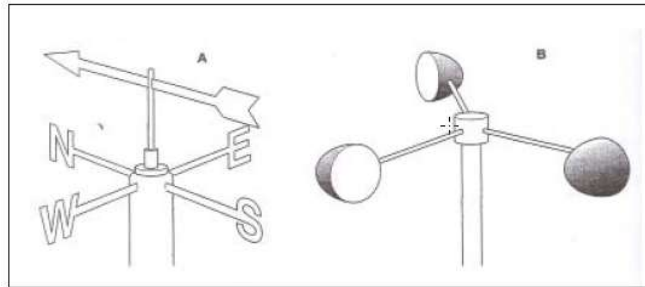

Fig. 11

CIE 2005

(i) Name each of the weather instruments shown. [2]

A _____
 B _____

(ii) For what purposes are the instruments used at a weather station? [2]

A _____
 B _____

(iii) Describe how each of the instruments works.

Instrument A [2]

Instrument B [2]

(f) Fig. 12 shows information about winds recorded at the school weather station.

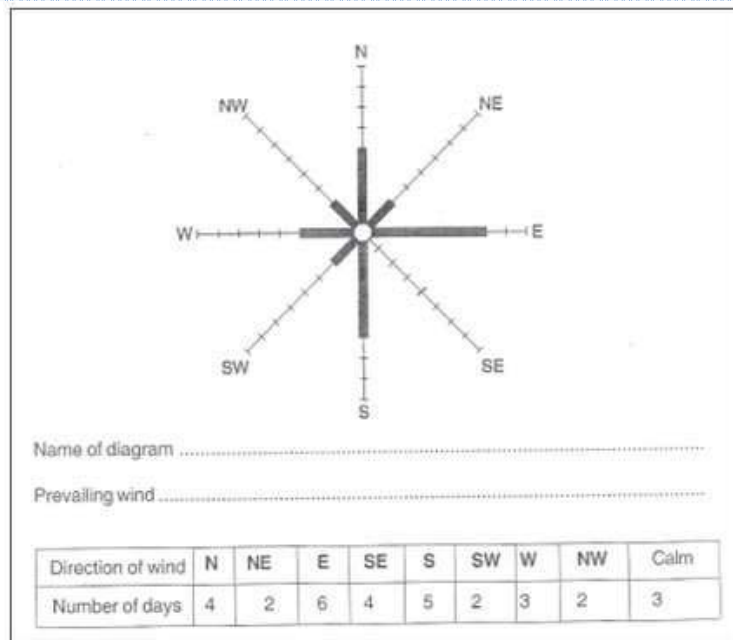

CIE 2005

Fig. 12

- (i) On Fig. 12 name the type of diagram used to give information about wind direction. [1]
- (ii) Complete the diagram by using the information provided in the table. [2]
- (iii) On Fig. 12 state the direction of the prevailing wind. [1]
- (g) Fig. 13 shows a box structure used at a weather station to store some weather instruments.

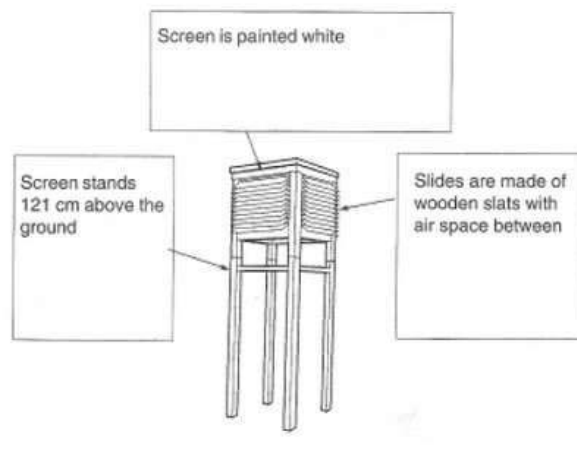

CIE 2005

Fig. 13

- (i) What name is given to the box shown? _____ [1]
- (ii) Complete the labels on Fig. 13 by adding the reasons for the features shown. [3]

(iii) Name two instruments that can be stored inside the box. [2]

(iv) Describe where, at a weather station, should the box be sited. [1]

Question 5

(a) Fig. 14 below shows a synoptic weather map.

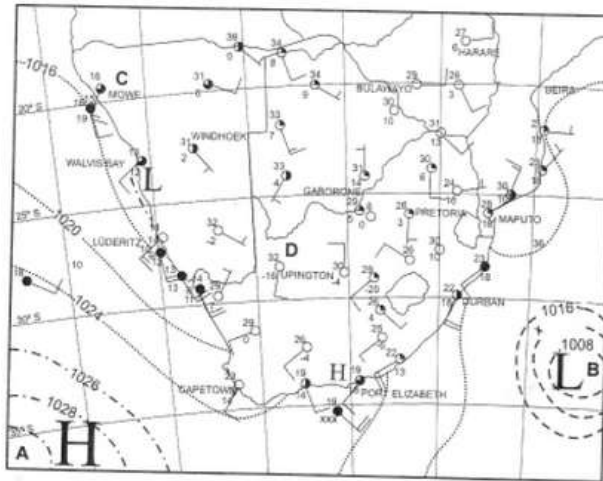

Namcol JSC Geography

Fig. 14

(i) State the following:

1. The wind speed at Windhoek _____ [1]
2. The cloud cover at Walvisbay _____ [1]

(ii) On the map, add the correct isobar value (X) which was left out at the low pressure system. [1]

(iii) Which season is shown on the synoptic weather map? _____ [1]

(iv) Give a reason for your answer in (ii). [1]

(v) Identify / name the high pressure system A on Fig. 14. [1]

(vi) Explain the clear skies experienced in Cape Town. [2]

Total Marks for Section B: [50]
Total Marks for Assignment 1: [100]

Assignment 1 Feedback



Assignment

SECTION A

Question 1

(a) (i) 90m (accept any value between 81-99m) [1]

(ii) 20m [1]

(iii) D – 30m [1]

E – 42m (accept 42 – 45m) [1]

F – 38m (accept 37 – 38m) [1]

(Accept variation in answers as indicated)

(iv) 1. Steep, because contour lines are close together. [2]

2. Gentle, because contour lines are far apart. [2]

(v) 60m [1]

(b) (i) + (ii)

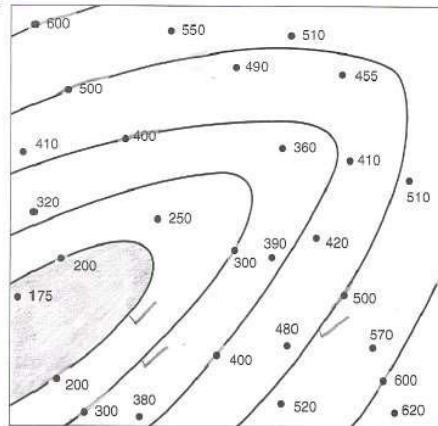

[3]

(iii) (steep-sided) valley [1]

(c)

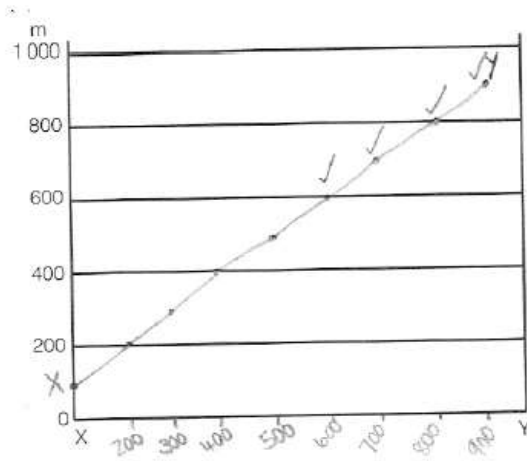

[4]

(d) (i) 1 – plateau

3 – conical hill

6 – valley

9 – escarpment

[4x1]

(ii) 2 – even / gentle slope

4 – convex slope

5 – terraced /stepped slope

7 – steep slope

[4x1]

(iii) XY: no intervisibility

[1]

PK: yes (two points are intervisible)

[1]

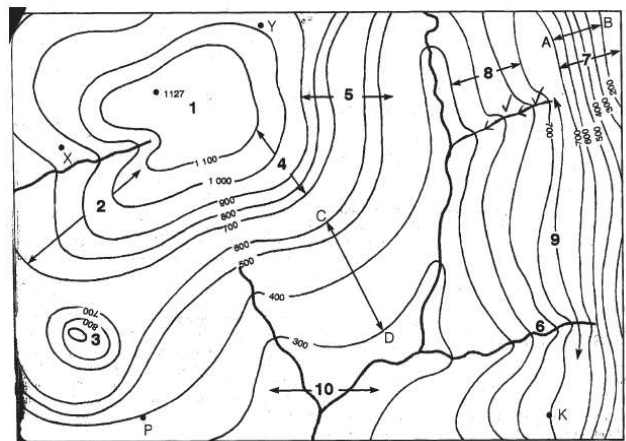

(iv) 1 mark - river

1 mark – direction (as shown above).

[2]

**Question 2**

- (a) 1cm = 500m / 0,5km [1]
- (b) trig. Beacon [1]
- (c) police station, school, fire brigade, hotel (any 2) [2]
- (d) river Chobe, Chobe National Park, hotel, Game scout camp, Kasana airstrip, hiking forest (any 2) [2]
- (e) north west [1]
- (f) 1. 300° [1]
2. 53° [1]
- (g) 1,8cm = 900m / 1,7cm = 850m [1]
- (h) 03°03'50" S (accept 48 – 52", but degrees and minutes must be accurate. [1]
80°29'35" E (accept 32 – 35", but degrees and minutes must be accurate. [1]
- (i) spot height 993 [1]

Question 3

- (a) vertical / aerial photograph [1]
- (b) urban area [1]
- (c) Many buildings
Many roads
Planned street pattern (any 1) [1]
- (d) 2 Advantages:
-no hidden areas or information
-show a lot of information
-can be used to draw maps (any 2) [2]
- (e) 2 Disadvantages:
-heights and surface slopes are not easy to identify
-much experience is required to obtain information from these photographs
-some calculations can be difficult
-expensive equipment is needed to take these photographs (any 2) [2]

Total Marks Section 1: [50]

SECTION B

Question 4

- (a) (i) W – maximum and minimum thermometer
 X – wet and dry bulb thermometer / hygrometer
 Y – barograph / barometer [3x1]
- (ii) 1. $8 - 2 = 6^{\circ}\text{C}$
 2. 1010mb
 3. 12mm
 4. 80% [4x1]
- (b) (i) rain gauge [1]
 (ii) X – meniscus
 height = 30cm (both MUST be shown on Fig. 8). [2]
 (iii) To prevent rain drops from splashing into the rain gauge
 To prevent surface water from running into the rain gauge.
 To prevent evaporation taking place. (any 1) [1]
 (iv) -Place the container on a flat surface.
 -Keep eyes level with the level of the water.
 -Take reading at the bottom of the meniscus. [3]
- (c) (i) Site S, because it is on a grass surface / in an open area. (any 1) [2]
 (ii) P and Q - Sheltered by the school building which may block rain from entering the gauge. [2]
 - Gutters may channel water into the gauge. (any 1)
 R – Between trees which may block rain or leaves may channel extra water into the gauge. [1]
- (d) (i) P – mercury
 Q – wet bulb
 R – cloth / wick
 S – water [4]
- (e) (i) A – wind vane [1]
 B – anemometer [1]
 (ii) A – wind direction [1]
 B – wind speed [1]
 (iii) A – the wind pushes against the tail causing the arrow to swing (\sim).
 The arrows points
 in the direction where the wind is blowing from(\sim) [2]
 B – the wind blows into the cups causing them to spin (\sim)
 the speed at which the cups rotate are read from a dial(\sim). [2]

[4]

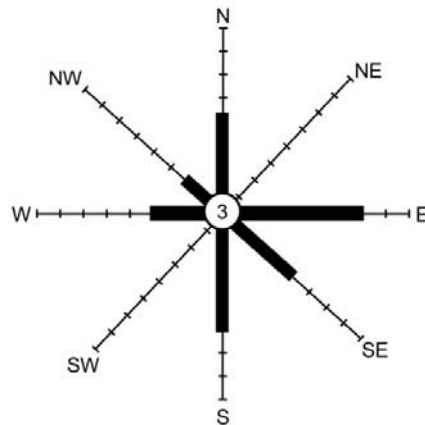

Name of diagram: wind rose~

Prevailing wind: east~

(g) (i) Stevenson Screen [1]

(ii) Painted white to reflect sunlight.

Wooden slats to allow the free movement of air into and out the box , but to keep sunlight out.

Stands 121cm above the ground to prevent heat from the ground to interfere with temperature readings. [3]

(iii) barograph / barometer

wet and dry bulb thermometer / hygrometer

maximum and minimum thermometer. (any 2) [2]

(iv) In an open area, away from trees and buildings. [1]

Question 5

(a) (i) 1. 5knots [1]

2. $\frac{3}{4}$ or $\frac{6}{8}$ or 75% [1]

(ii)

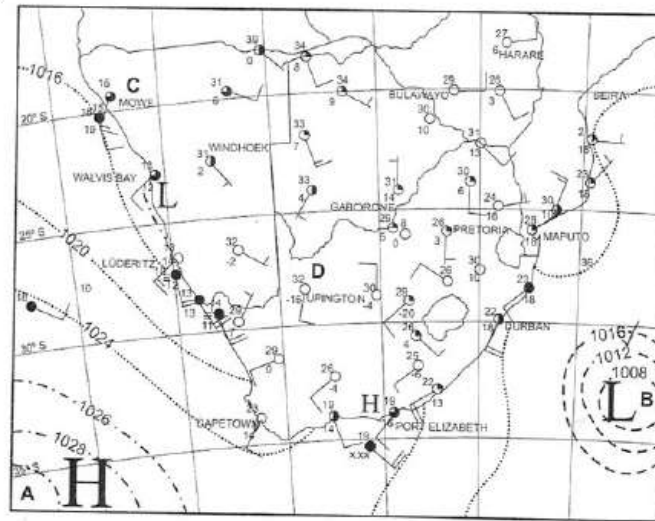

- 1012mb as indicated on map. [1]
- (iii) summer [1]
- (iv) -Much cloud cover over interior– summer rainfall area
 Maximum temperature readings over interior above 30°C
 -Atlantic High Pressure System has moved southwards. (any 1) [1]
- (v) Atlantic High Pressure System [1]
- (vi) -Cold, dense air in high pressure system descends
 -Dense air cannot hold water vapour
 -No condensation and cloud formation can take place. [3]

Total Marks for Section B: [50]

Total Marks for Assignment 1: [100]

Unit 3

Ecology

Introduction

Ecology is the relation of organisms to one another and to their physical surroundings. This unit will focus on the interaction between organisms, people and their environment. We will explore issues around Namibia's rapidly deteriorating environment and identify and explain man-made causes for this deterioration, such as deforestation, desertification, pollution and overpopulation. We will look at farming methods that contribute to deforestation and desertification as well as suggest solutions to help prevent further environmental deterioration in Namibia and the world as a whole. Before we proceed let's pause for a moment by looking at the unit outcomes first.

Upon completion of this unit you should be able to:



Outcomes

- *distinguish* between natural causes and human-made causes;
- *describe* farming methods as a cause of deforestation and desertification;
- *describe* the causes and effects of bush encroachment;
- *explain* the effects of population explosion as a worldwide as well as a Namibian problem;
- *describe* pollution of the land, water and the atmosphere;
- *suggest* solutions for problems from their own vicinity, e.g., population education, environmental education, sustainable production, etc.;
- *transfer and apply* this knowledge to the solution of problems in other areas.

Now that you have studied the outcomes and know what is expected of you I want you to look at the timeframe first to see how much time is needed to complete this unit.



How long?

You will need approximately 25 hours to complete the unit.

Now that you have familiarize yourself with the time study the following terminologies first.



Terminology

ecology:	is the scientific study of the distribution and abundance of organisms and their interactions with their environment.
deforestation:	is the logging and burning of trees in a forested area.
desertification:	is the degradation of land in arid and dry sub-humid areas, resulting primarily from natural activities and influenced by climatic variations.
desertisation:	is the process whereby it is caused by nature such as a bad drought.
bush encroachment:	is the change in vegetation from open savanna, or mixed grass and woodland, to shrubland.
afforestation:	is the process of establishing a forest on land that is not a forest, or has not been a forest for a long time by planting trees or their seeds. The term may also be applied to the legal conversion of land into the status of royal forest.
re-afforestation:	is the restocking of existing forests and woodlands which have been depleted, with native tree stock. The term reforestation can also refer to afforestation, the process of restoring and recreating areas of woodlands or forest that once existed but were deforested or otherwise removed or destroyed at some point in the past.
overgrazing:	occurs when plants are exposed to intensive grazing for extended periods of time, or without sufficient recovery periods. It can be caused by livestock in poorly managed agricultural applications.
Overstocking:	stock excessively; amass so as to keep for future use or sale or for a particular occasion or use.
Overcultivation:	over stimulation; is the process of getting fatter plants (specifically crops) on arable land. It is usually associated with large-scale agriculture, as opposed to small-scale gardening.
pollution:	is the introduction of contaminants into an environment that causes instability, disorder, harm or discomfort to the ecosystem i.e., physical systems or living organisms .
global warming:	is the increase in the average temperature of the earth's near-surface air and oceans since the mid-



twentieth century and its projected continuation.

greenhouse effect:	refers to the change in the steady state temperature of a planet or moon by the presence of an atmosphere containing gas that absorbs and emits infrared radiation.
logging:	is the process in which certain trees are cut down for forest management and timber.
ranching:	a ranch is an area of landscape, including various structures, given primarily to the practice of ranching , the practice of raising grazing livestock such as cattle or sheep for meat or wool.

Section 1

Deforestation



Section outcomes

8.9% or about 7,290,000
ha of Namibia is
forested – *MongaBay.com*

Upon completion of this section you should be able to:

- *distinguish* between natural and man-made causes of deforestation;
- *describe* farming methods as a cause of deforestation;
- *describe* the problems caused by deforestation;
- *make* suggestions to combat deforestation.

What is 'deforestation'?

An area is deforested when people cut down trees faster than what they can be replaced.

We often think that deforestation does not affect the lives of people living in urban areas. However, city dwellers also contribute to deforestation, they just do not know it. Deforestation is a global problem and people all over the world should become aware of the problems caused by it.

The map below shows areas in the world where deforestation occurs.

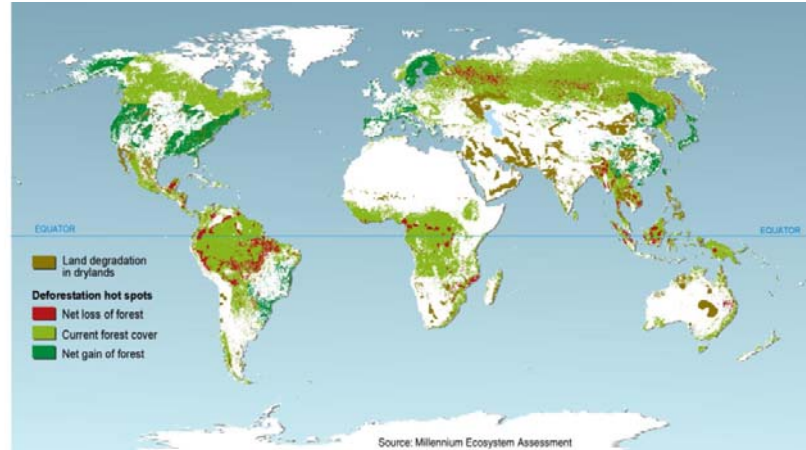

Figure 3.1
<http://nksandeeep.files.wordpress.com/2009/03/sdm-gene-02-deforestation.jpg>



Figure 3.2
wikispaces.com/%252ffile%252fview%252fdeforestation.jpg%252f143727523%252fdeforestation.jpg

Why are trees important?

Trees form a very important part of our environment:

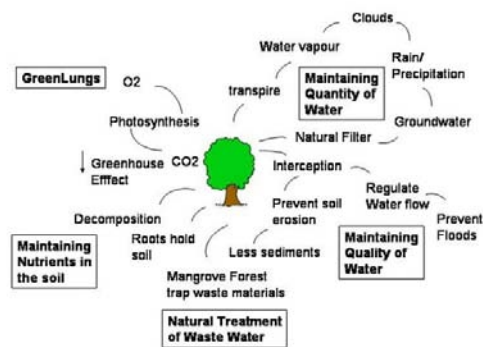

Figure 3.3
http://1.bp.blogspot.com/_4fcj5HMB_IM/S2t92bVaIyI/AAAAAAAAAAcQ/w05PDExPMVw/s1600-h/images.jpg

So we see that trees:

- balance the oxygen-carbon dioxide levels in the atmosphere
- their leaves absorb rainwater and give moisture to the atmosphere through transpiration
- their roots hold soil together and reduce soil erosion
- rivers remain cleaner as less sediments are washed into them
- slow down surface run-off, allowing more water to penetrate the soil
- their canopies slow down heavy rainfall and so reduce soil erosion
- shed their leaves which decompose and return nutrients to the soil

Trees are also important because:

- they form a natural habitat for birds and insects
- they provide fruit to animals and people
- they provide shade to animals and people
- their roots, leaves, bark and sap can be used to make medicine

Why do people cut down trees?



Figure 3.3

http://3.bp.blogspot.com/_4fcj5HMB_IM/S2psUBA25xI/AAAAAAAAeA/5ysZ-GQLHEA/s1600-h/images.jpg

More reasons for clearing vegetation include:

- using wood for heating purposes
- to plant crops
- for cattle ranching
- to expand towns and cities
- for mining purposes
- for road building
- to build hydro-electric power stations



Figure 3.4

<http://wikieducator.org/File:Laterit.jpg>

Land clearing for mining purposes

How do farming methods contribute to deforestation?

When people require large areas for agriculture, many trees are cleared so that these areas can be used for crop plantations and cattle ranching. Soils become exhausted due to over-cultivation and trampling by animals. Natural vegetation cannot recover.



Figure 3.5

Source: National Geographic

Huge forest areas cleared for cattle grazing

In certain parts of the world slash and burn methods are practised. Trees are burned to clear large areas for crop production.



Figure 3.6



Source: <http://virtual.vtt.fi/space/firealert/images/heinavesi.jpeg>

Slash and burning in Indonesia

Slash and burn also occurs in Africa on a large scale.

The following insert was taken from :*Source below picture*

“Deforestation in Malawi, Africa, is a major problem, and 30% of the forests have disappeared in the last 10 years. Deforestation is happening very quickly on a frightening scale, and there is tremendous pressure on the natural resources because of the burgeoning population.”

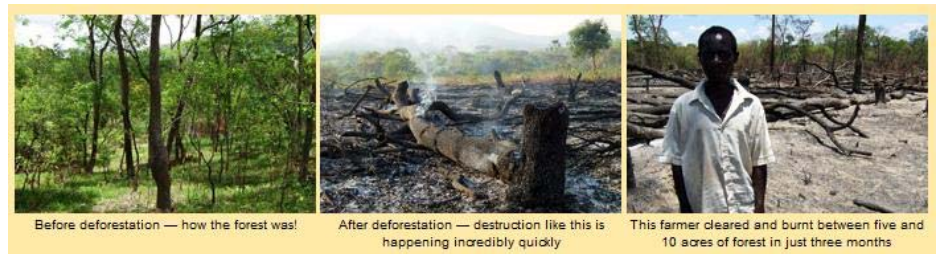

Figure 3.7

Source: www.appinsys.com/GlobalWarming and [\[http://www.rippleafrica.org/ripple_funding_trees_update2007.htm\]](http://www.rippleafrica.org/ripple_funding_trees_update2007.htm)

How is deforestation caused naturally?

Have you noticed that the reasons for deforestation described above are all man-made? This means that humans were responsible for cutting down trees.

But sometimes natural factors can cause deforestation. This is when deforestation occurs due to natural factors, which are beyond human control. Natural causes of deforestation include:

- Drought
- Very little rainfall
- Natural forest fires

(Insert pictures showing drought and forest fires)

Drought



Figure 3.9

(Source unknown – find another picture)

What are the problems caused by deforestation?

- Natural habitat for birds and insects are destroyed
- No food for animals, causing animals to migrate in search for food or to die out
- Fewer trees to release oxygen and absorb carbon dioxide. Carbon dioxide builds up, contributing to the greenhouse effect and global warming.
- Fewer leaves are shed, so fewer nutrients are added back to the soil causing infertile soil.
- Less infiltration of water leading to lower groundwater levels.
- Fewer roots to bind the soil leading to increased soil erosion.
- More surface run-off which increases erosion of top soil.
- Sediments are washed into rivers making water muddy or dirty.
- Sediments are deposited on riverbed causing water levels to rise.
- Higher water levels could lead to flooding.
- Soils on steep slopes become unstable and could lead to more landslides and mudslides.
- Removal of indigenous people from deforested areas.

Top
sun
is c

Effects of deforestation

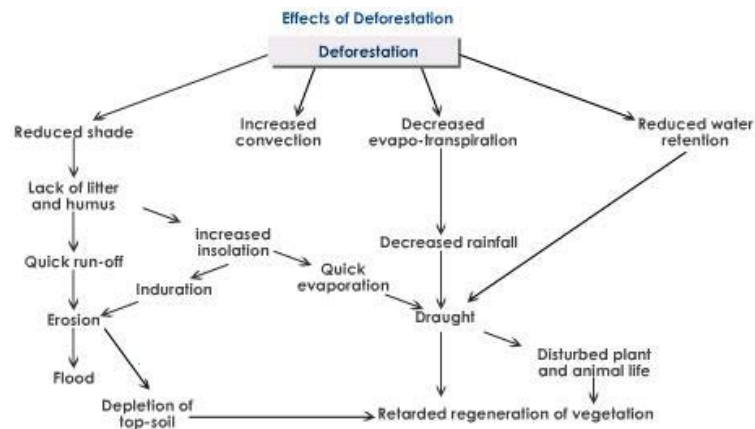

Figure 3.10

<http://image.wistatutor.com/content/biodiversity/deforestation-effects-biosphere.jpeg>



Problems of Deforestation

- Burning → Haze, smoke, dust
- Green Lungs → Global Warming
- Hold soil together → Drop in Quality of Water
- Interception → Floods
- Nutrients Cycle → Loss of Biomass
- Habitats for Flora and Fauna → Loss of Biodiversity

Figure 3.11

Source: http://3.bp.blogspot.com/_4fcj5HMB_IM/TKpp1RV3w3I/AAAAAAAAAf8/xQ3FDoNpY2M/s1600/untitled1.jpg

What can be done to reduce deforestation?

- Educate people about the importance of trees and of the importance of their own contribution to preserve trees.
- Introduce sustainable farming methods, such as intercropping. This entails planting crops in rows between existing trees.
- Plant more trees.
- Trees must also be replanted in areas where they have been cleared.
- Instead of wood, use other building materials such as bricks to build houses and wire to make fences.
- Use renewable resources such as solar energy or wind power for cooking and heating or other types of energy like gas or paraffin.
- The government should introduce laws that put restrictions on the amount and type of trees that may be cut down.
- Use digitized methods to store and share information, e.g. compact discs, memory sticks, electronic mail. This will reduce the use of paper.

Next we will do activity 4

Activity



Activity

Time Required: In this activity you need at most 45 minutes to fully answer the question.



How long?

Read the newspaper article below and answer the following questions



22.04.2005

Namibia must stop deforestation

By: STAFF REPORTER

IT is imperative that Namibia finds ways to halt deforestation so that it can prevent and halt desertification, says Agriculture and Forestry Minister Dr Nickey Iyambo.

"Desertification is still taking place at an alarming pace," Iyambo warned on Wednesday. His comments came in a speech read on his behalf by his Deputy, Paul Smit, at an occasion marking the end of the Namibia-Finland Forestry Programme.

Through the project, the Scandinavian country financial and technical helped Namibia develop its forest sector. Thirteen forests have already been declared community forests while 16 others are up for designation.

The Forestry Act of 2001 grants rights to communities to establish community forests, which they have to manage and from which they derive benefits. Iyambo said that to accelerate the recovery process of forest resources, it was imperative that Namibians engaged in tree-planting activities.

Iyambo has pledged to plant 1,5 million trees every year, the Ministry's Permanent Secretary Kahihoro Kahuure said at the occasion. His comments came in a speech read on his behalf by his Deputy,

1. What, according to the Minister of Forestry and Agriculture, is a direct result of deforestation? [1]
2. Why is deforestation taking place at 'alarming pace' in Namibia? [3]
3. Why is Minister Iyambo concerned about the fast rate of forest depletion in the country? [3]
4. Describe one measure taken by Namibia and Scandinavia to combat deforestation in Namibia. [1]
5. Explain how the Forestry Act of 2001 benefits communities. [1]
6. What example does Minister Iyambo set for the country in order to reduce deforestation? [1]
7. Describe four other measures which can be taken to fight deforestation. [4]

Once done with the activity, please compare your answers with mine before you proceed.



Feedback

Answers:

1. desertification
2. In Namibia many trees are cut down to be used as:
 - fuel wood
 - building and fencing material
 - to clear areas to grow crops
3. Harm is done to the environment in the following ways:
 - Natural habitat for birds and insects are destroyed
 - No food for animals, causing animals to migrate in search for food or to die out.
 - Fewer trees to release oxygen and absorb carbon dioxide. Carbon dioxide builds up, contributing to the greenhouse effect and global warming.
 - Fewer leaves are shed, so fewer nutrients are added back to the soil causing infertile soil.
 - Less infiltration of water leading to lower groundwater levels.
 - Fewer roots to bind the soil leading to increased soil erosion.
 - More surface run-off which increases erosion of top soil.
 - Sediments are washed into rivers making water muddy or dirty.
 - Sediments are deposited on riverbed causing water levels to rise.
 - Higher water levels could lead to flooding.
 - Soils on steep slopes become unstable and could lead to more landslides and mudslides.
 - Removal of indigenous people from deforested areas.
4. Scandinavia has helped Namibia to develop its forest sector. Thirteen forests have been declared community forests and 16 more forests are up for designation.
5. The Forestry Act of 2001 grants rights to communities to establish community forests, which they have to manage and from which they derive benefits.
6. He encourages Namibians to plant trees.
7. Educate people about the importance of trees and of the importance of their own contribution to preserve trees.

Introduce sustainable farming methods, such as intercropping.
This entails planting crops in rows between existing trees.

Instead of wood, use other building materials such as bricks to build houses and wire to make fences.

Use renewable resources such as solar energy or wind power for cooking and heating or other types of energy like gas or paraffin.

The government should introduce laws that put restrictions on the amount and type of trees that may be cut down.

Use digitized methods to store and share information, e.g. compact discs, memory sticks, electronic mail. This will reduce the use of paper.

Section 2

Desertification



Section outcomes

Upon completion of this section you should be able to:

- *distinguish* between natural and man-made causes of desertification;
- *describe* farming methods as a cause of desertification;
- *suggest* possible solutions to combat desertification.

What is ‘desertification’?

Can you see that the word ‘desertification’ contains the word ‘desert’? Deserts receive small amounts of annual rainfall and soils are infertile which makes them uninhabitable. ‘Desertification’ occurs when previously vegetated and productive land turns into a desert-like area due to overuse of land. This means that land becomes degraded

Which areas in the world are at risk of desertification?

(Insert map with the world’s deserts including areas at risk of desertification).

So here we can see that areas next to and close to deserts are already at risk because of very low amounts of rainfall received. Such areas are referred to as ‘marginal land’ because their productivity is very low. Can you see that Namibia contains large areas at risk of desertification? Namibia’s situation is made worse due to the presence of the Namib and the Kalahari Deserts. These two deserts are expanding (Google rate of expansion and insert)

But why is it a problem for our country and its people?

(Google)??% of Namibians makes a living directly from the land. This means that they are dependent on crop production and the rearing of animals to provide food for themselves and their families.

Let us look at the following map which shows us what is happening to the size of deserts across the world.

(Insert map which shows that deserts are expanding).

Can you see that the deserts are expanding? When deserts expand due to natural causes such as less rainfall in an area, it is referred to as 'desertification'. When deserts expand due to human impact such as over-extraction of groundwater, it is referred to 'desertisation'.

Main causes of desertification:

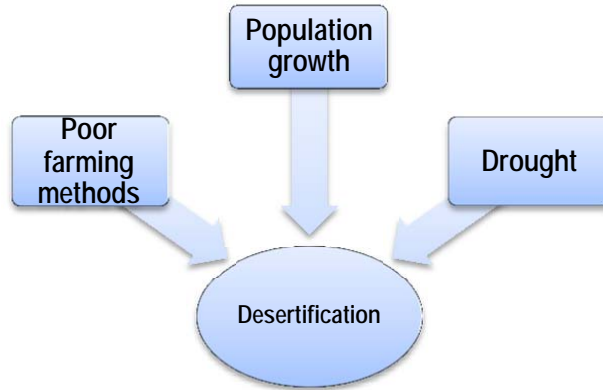

Figure 3.12

Population growth:

Population growth leads to deforestation which accelerates (speeds up) desertification:

- More people require more living space so trees are felled to create space for settlements.
- More people require more food to eat so trees are cut down to make space to cultivate crops and for grazing land for livestock.
- More energy is required resulting in cutting down of more trees to use for firewood.

Poor farming methods:

A greater demand for food supplies leads to the following:

- Farmers cultivate crops in areas that are prone to drought
- Farmers have less fallow periods because they do not have enough land to allow certain pieces of land to recover.
- Fertiliser is applied incorrectly to try to revitalise the soil.
- Incorrect irrigation methods which lead to salinisation which makes land even more unproductive.
- Only one type of crop is planted.
- Too many livestock is kept which lead to overgrazing and soil trampling.

Many farmers in Namibia are poor and do not have alternative means of making a living. Growing crops and rearing a few animals are often their only way of supplying food for their families. So they are left with no other choice but to exploit the land to produce food.

Drought:

- Due to very little rainfall groundwater levels are not always recharged to its previous levels.
- Farmers continue to extract more and more water for their needs leading to increasing drought and desertification in an area.

Possible solutions:

- Plant more trees.
- Educate farmers about improved farming methods e.g. better irrigation methods, to reduce stock during dry seasons when grazing is scarce and to restock during wetter seasons.
- Farmers should fence off newly planted trees to protect them from animals.
- Reduce the pressure on land by not allowing too many people living in an area.
- Promote public awareness on desertification.
- Improve the socio-economic status of rural farmers / reduce poverty so that people are not so dependent on land for food.

But why is it so difficult to fight desertification?

- Wood is the only source for cooking and heating in many rural areas.
- Natural vegetation takes long to recover fully due to low rainfall.
- People are not educated about the dangers of desertification.
- The government should improve monitoring and research on desertification.
- Encourage and educate people about the use of alternative energy resources and building material.

Let's do activity 5

Activity 5



Activity

Time Required: In this activity you need at most 45 minutes to fully answer the question.



How long?

Read the newspaper article below and answer the questions that follow to test your knowledge of desertification.

Fri, 13 May 2011



Namibia fights desertification

“As a country highly dependent on agriculture and especially livestock farming, it has become a matter of urgency to recover the productive capacity of our land. In Namibia, including the Erongo Region, desertification has already had a devastating impact.”

These remarks were made by the Governor of the Erongo Region, Samuel Nuuyoma, at Omatjete in Namibia last week.

He said food security is threatened by desertification and biodiversity loss everywhere in the world. “We are concerned as such that information and knowledge on desertification becomes essential to be shared with all at all levels. Gone are the days where only a few could be allowed to make decisions for masses without adequate consultations and consent. Food shortages due to desertification affects everyone and therefore collective decision making on counter actions are inevitable,” Nuuyoma said.

He made the remarks at the country’s World Day to Combat Desertification celebrations held at the villages some 60km from Omaruru.

The event was organised by the Namibia Country Pilot Partnership Programme (CPP). This United Nations Development Programme (UNDP) initiative resorts under the Ministry of Environment and Tourism.

At the occasion, a speech was also read on behalf of the UN Secretary General Ban Ki-moon in which he called for a focus on the links between biodiversity, land and climate change. He said that the human, environmental and social vulnerability come together with unusual force and symmetry in the world’s dry lands. “Climate change will only exacerbate such pressures.”

Nuuyoma further said that a problem can only be solved once one actually realises that there is a problem. “Only then we can focus our energies on possible solutions.”

Once done with the activity, please compare your answers with mine before you proceed.



Feedback

1. Why is it important to recover the productive capacity of land in Namibia? [1]
2. Describe two serious impacts of desertification in Namibia, as explained by the Governor. [2]
3. Describe two other consequences of desertification in Namibia. [2]
4. Explain how the Governor wishes to involve different people in the efforts to combat desertification. [1]

Section 3

Bush encroachment

You have heard of this term before and by now it should be familiar to you, but if we look at some synonyms of the word encroachment it becomes clear what it is all about. Words like infringement, intrusion or violation of what we can ask ourselves? In this section we will look at the problem of bush encroachment as one of the reasons for the deterioration of the Namibian environment. Before you continue study the section outcomes first.

Upon completion of this section you should be able to:



Section outcomes

- *describe* the causes of bush encroachment;
- *suggest* possible solutions to the problem;
- *describe* the effects of bush encroachment;
- *suggest* possible solutions to the problem.

Bush encroachment in Namibia

According to Moore, (2010) invasive bush species in Namibia makes large areas of land unusable and creates a problem for rural farmers. This means that large areas become unusable and as a result it affects 26 million hectares of farmland in Namibia and this has led to a 60 percent decline of commercial livestock over the last 40 years. This has an impact and causing losses to the national economy. This statistics were received from Combating Bush Encroachment for Namibia's Development (CBEND). Further effects of this "invader bush," includes the



desertification of Namibia. These results were received from Namibia's Ministry of Environment and Tourism (MET).

To control this invasion is expensive and a majority of farmers cannot afford bush clearing. This has an impact on sustainable livestock and standards of living, especially in rural areas.

Solution

The Desert Research Foundation of Namibia (DRFN) and CBEND are providing a solution by converting the invading bush, which is devastating the land, into energy.



In-text question

Can you think of any solutions to this "invader bush" problem?

How the question, but the CBEND project is planning to install wood gasification plants. The invader bush will be used as fuel to produce electricity, in northern Namibia. Electricity produced by the plant will then provide power to the national network. The project began in 2007 when the DRFN submitted a proposal to the European Commission Rural Poverty Reduction Programme for funding.



Figure 3.13

Source: Moore, J. K. (2010).

<http://allafrica.com/stories/201002251315.html>

Ankur Scientific Energy Technologies won the bid to produce the wood gasification power plants, of which they have similar units in place around the world. The source of fuel for this project is wood and the invader bush provides an indigenous, sustainable, and renewable fuel source. It is called a gasifier plant system and it works by converting biomass materials into combustible gas. A single wood gasification plant will be able to generate 0.25 megawatts (MW) of power. To generate more energy more power plants are needed, but there is a combined potential of over 200 plants in Namibia, which could produce about 20 percent of Namibia's electricity. This invader bush is a cheap resource for producing energy.

How will the success be measured? The success for CBEND's with the gasification plants will be measured by:

- the reliability of the technology,
- the feasibility of farmers to operate as independent power producers, and
- how financially productive the plants will be at creating energy.

Section 4

Overpopulation

Have you ever wondered about the term overpopulation? The Encarta dictionary describes it as to increase the population of a place so much that the amount of space, food, water, or other resources available to support it is insufficient. With the description in mind we will look in this section at the damage done to the environment by overpopulation. First you need to familiarize yourself with the section outcomes.

Upon completion of this section you should be able to:



Section outcomes

- explain the problems caused by overpopulation;
- suggest some solutions to the problem.

Definition

Overpopulation is a term that refers to a condition by which the population density enlarges to a limit that provokes the environmental deterioration, a remarkable decline in the quality of life, or a population collapse.

The term population density refers to the number of people in a specific area, for example: 100 people per square kilometre.

The impact of human populations on the environment has been severe for example:

- animal species have been extinguished or forced to live in unfriendly regions by the advance of urban areas;
- pollution is a problem that is increasing gradually because we are using more cars;
- emerging countries industrialization is not paying attention to environmental issues because of the feeding demands of their ever-growing populations.



The human overpopulation has been credited to different factors such as:

- the increase in life-span,
- the absence of natural enemies,
- the improvement in the quality of life, and
- the accessibility to get better goods and services.

The effect of overpopulation is that every year, more than 81 million people are added to the world-wide population. As a result every 10 years almost one billion inhabitants are added to the world's population.



In-text question

What do you think will be the effects of overpopulation? Give your opinion.

Effects

Sixteen (16) million hectares of forest are chopped down each year to make space for humans. I want you to read the followings statements about the effects of overpopulation.

- The accelerated growth of the human populations has propitiated the destruction of natural habitats of many species.
- People are invading the habitats of those species, replacing them to inhospitable places and condemning the native species to the extinction.
- The speed of extinction of plants and animals attributable to human activities is 10,000 times faster than the natural quotient.
- About 5 million people die every year from illnesses associated to organic wastes.
- Too dense human communities produce tons of solid wastes (organic and inorganic waste) daily, consume large quantities of energy and emit more pollutants to the environment.
- Water necessities will increase to 20% by 2025. Approximately, one half of wetlands around the world have been lost since 1900.
- In USA, consumption of materials (wood, metals, synthetics, etc.) has grown 18-fold since 1900.
- The Ozone layer has been gradually ruined by the effect of the CFCs.
- The concentration of CFCs has been increased as the human population has grown, and the thickness of the Ozone layer has been lesser to the extent that a hole in the layer has been formed. Scientists have found that there are other emissions derived from human activities, which have contributed to the depletion of the ozone layer.

More effects

Some problems associated with or exacerbated by human overpopulation:

- **Inadequate fresh water** for drinking water use as well as sewage treatment and effluent discharge. Some countries, like Saudi Arabia, use energy-expensive desalination to solve the problem of water shortages.
- **Depletion of natural resources**, especially fossil fuels.
- Increased levels of **air pollution, water pollution, soil contamination and noise pollution**. Once a country has industrialized and become wealthy, a combination of government regulation and technological innovation causes pollution to decline substantially, even as the population continues to grow.
- **Deforestation and loss of ecosystems** that sustain global atmospheric oxygen and carbon dioxide balance; about eight million hectares of forest are lost each year.
- **Changes in atmospheric composition and consequent** global warming.
- Irreversible **loss of arable land** and increases in **desertification**. Deforestation and desertification can be reversed by adopting property rights, and this policy is successful even while the human population continues to grow.
- **Mass species extinctions** from reduced habitat in tropical forests due to slash-and-burn techniques that sometimes are practiced by shifting cultivators, especially in countries with rapidly expanding rural populations; present extinction rates may be as high as 140,000 species lost per year.
- High **infant and child mortality**. High rates of infant mortality are caused by poverty. Rich countries with high population densities have low rates of infant mortality.
- **Intensive factory farming** to support large populations. It results in human threats including the evolution and spread of antibiotic resistant bacteria diseases, excessive air and water pollution, and new virus that infect humans.
- Increased chance of the emergence of **new epidemics and pandemics**. For many environmental and social reasons, including overcrowded living conditions, malnutrition and inadequate, inaccessible, or non-existent health care, the poor are more likely to be exposed to infectious diseases.
- **Starvation, malnutrition** or poor diet with ill health and diet-deficiency diseases (e.g. rickets). However, rich countries with high population densities do not have famine.
- Poverty coupled with **inflation** in some regions and a resulting low level of capital formation. Poverty and inflation are aggravated by bad government and bad economic policies. Many countries with high



population densities have eliminated absolute poverty and keep their inflation rates very low.

- **Low life expectancy** in countries with fastest growing populations
- **Unhygienic living conditions** for many based upon water resource depletion, discharge of raw sewage and solid waste disposal. However, this problem can be reduced with the adoption of sewers. For example, after Karachi, Pakistan installed sewers, its infant mortality rate fell substantially.
- **Elevated crime rate** due to drug cartels and increased theft by people stealing resources to survive
- Conflict over scarce resources and crowding, leading to **increased levels of warfare.**
- **Less Personal Freedom / More Restrictive Laws.** Laws regulate interactions between humans. Law "serves as a primary social mediator of relations between people." The higher the population density, the more frequent such interactions become, and thus there develops a need for more laws and/or more restrictive laws to regulate these interactions. It is even speculated that democracy is threatened due to overpopulation, and could give rise to totalitarian style governments.

Trends of population growth

World Population (update: July 2006) = 6,525,170,264 humans

The rate of population growth has dropped since 1963. The rate of global growth before the 1960s was near to 2.4 percent, at present the rate has dropped to 1.27 percent.

If you observe the current tendency, you could assume that all works well, but actually, it does not. Actually this global picture has been obtained taking into account mainly European countries, as Germany and Holland, which hold a negative rate. On the other hand, some countries maintain rates of growth over 4 percent each year.

For example, the Ethiopia's current population of 60 million inhabitants is projected to near 170 million by 2050.

By 2050, India will displace to China from its first place in growth rate, with an increment of 550 million additional inhabitants to its present population of more than one billion.

Pakistan will almost triple its population by 2050, from 142 to 350 million. If the world population continues growing at an average of three children by couple, the global population for 2050 will be of 10.5 billion inhabitants, from whom 7.7 billion will suffer for extreme poverty, lack of fresh water, hunger, illnesses, etc.

In some cases, the five countries at the first level of population growth (China, India, USA, Indonesia and Brazil) will continue in their current rank because the rate of mortality in poor countries exceeds the rate of births. If this tendency upturns, then those countries will have population growths of around five percent by year.

Causes of Overpopulation

Decline in the Death Rate:

The fall in death rates that is decline in mortality rate is one fundamental causes of overpopulation. Owing to the advancements in medicine, man has found cures to the previously fatal diseases. The new inventions in medicine have brought in treatments for most of the dreadful diseases. This has resulted in an increase in the life expectancy of individuals. Mortality rate has declined leading to an increase in population. Owing to modern medications and improved treatments to various illnesses, the overall death rate has gone down. The brighter side of it is that we have been able to fight many diseases and prevent deaths. On the other hand, the medical boon has brought with it, the curse of overpopulation.

Rise in the Birth Rate:

There are medicines and treatments, which can help in conception. Thus, science has led to an increase in birth rate. This is certainly a reason to be proud and happy but advances in medicine have also become a cause of overpopulation.

Migration:

Immigration is a problem in some parts of the world. Crowding of immigrants in certain parts of the world, results in an imbalance in the density of population.

Lack of Education:

Illiteracy is another important cause of overpopulation an as a result of that people:

- fail to understand the need to prevent excessive growth of population;
- do not understand the harmful effects that overpopulation has;
- are unaware of the ways to control population;
- lack the understanding of family planning;
- are ignorant and they do not take to family planning measures.

Viewing the issue of increasing population optimistically, one may say that overpopulation means the increase in human resources. The increase in the number of people is the increase in the number of productive hands and creative minds. But we cannot ignore the fact that the increase in the number producers implies an increase in the number of consumers. Greater number of people requires a greater number of resources.



Solutions

Overpopulation effects are famously documented. Apart from the food and mineral scarcities, it is commonly agreed by other members of nature that humans are a troublesome lot and too many of us for too long will effectively lead to the ruin of the earth. Jokes apart, overpopulation solutions need to be humane and quite frankly doable. So here are some of the overpopulation solutions, which might ease overpopulation problems. Before you look at the solutions that has been provided consider the in-text question first.



In-text question

What would you consider as solutions to overpopulation?

Education

Uneducated people are regarded as the most commonly agreed cause of overpopulation because they have:

- more needy children ;
- a lack of family planning ;
- a lack of knowledge of the effects of overpopulation; and
- no ability to nurture their children well enough.

Basic education will also help people understand the problems of overpopulation and those associated with bringing up children as well. One of the best overpopulation solutions is to provide good basic education to all the people in the country, so that they may learn the problems of overpopulation and exercise self-discipline.

Family Planning

It is important in a country to educate people about the problems of population growth. Many countries have a family planning division in the government. This has proven to be a very effective solution to overpopulation, because it:

- helps married couples understand the problems of overpopulation;
- encourage others to either exercise abstinence or educate people about safe sex techniques;
- gives people adequate knowledge of contraceptives; and
- is also one of the country's best government sponsored solutions.

Tax Breaks

This has proven to be very successful in many countries by offering lowered income tax rates or tax deductions to married couples who exercise restraint and choose not to produce more than one or two children. On the other hand, couples with more than three children can be

taxed heavily.

Sex-Ed

It is found that talking about the birds and the bees is viewed as forbidden in a lot of cultures, but when the overpopulation problem is so evident, moral correctness has to go. Sex education needs to be made mandatory in schools. Sex education is also something that parents tend to postpone for a long time. It is one of the most important overpopulation solutions that we get rid of the old inhibitions and the cover-up of morality for the better.

Health Care

It is scary to think that in this modern era people actually think that their children will die at a young age and therefore they have more children. By providing the children and new mothers with proper health care, is one of the best solutions to overpopulation as their mortality rates will be reduced and this assumption of infant death will be done away with.

If we look at these overpopulation solutions it is clearly evident that they are doable. One important fact here is education and it is only with education that people will know the hazards of overpopulation and abstain from producing more children. Now that we have discussed overpopulation issues it is time for you to test your knowledge by doing the next activity.

Activity



Activity

Time Required: In this activity you need at most 45 minutes to fully answer the question.

Read the article on overpopulation and answer the questions that follow.



How long?

[Planet Could Be 'Unrecognizable' by 2050, Experts Say.](#)

February 20, 2011 Yahoo News

At the annual meeting of the American Association for the Advancement of Science (AAAS) it was warned that a growing, more affluent population competing for ever scarcer resources could make for an unrecognizable world by 2050. Global population is projected to reach nine billion by 2050, "with almost all of the growth occurring in poor countries, particularly Africa and South Asia," said John Bongaarts of the non-profit Population Council.

To feed all those mouths, "we will need to produce as much food in the next 40 years as we have in the last 8,000," said Jason Clay of the World Wildlife Fund.

But incomes are also expected to rise over the next 40 years -- tripling globally and quintupling in developing nations -- and add more strain to global food supplies.

People tend to move up the food chain as their incomes rise, consuming more meat than they might have when they made less money. Seven pounds of grain are required to produce a pound of meat, and around three to four pounds of grain to produce a pound of cheese or eggs.

Population experts called for more funding for family planning programs to help control the growth in the number of humans, especially in developing nations. ■

Questions

- 1.
- 2.
- 3.
- 4.
- 5.

Once done with the activity, please compare your answers with mine before you proceed.



Feedback

1.

I hope you have managed to do the activity. In the next section we will look at pollution.

Section 5

Pollution

In section 4 we discussed overpopulation and one of the negative effects of overpopulation is pollution. We will, however, in this section take a closer look at the problems caused by land, water and air pollution and we will find solutions to these problems as well. First I want you to look at the section outcomes.

Upon completion of this section you should be able to:



Section outcomes

- *explain* the problems of land, water and air pollution;
- *suggest* some solutions to these problems.

Land pollution

Land pollution occurs everywhere and it is an ugly site to see and to think of it, it is us who are responsible for that. We are destroying our earth daily. We can therefore say that land pollution is about the contamination of the land surface and soil of the Earth. Take a close look at the picture and ask yourself the question, why are we doing it?



Figure 3.14

Land pollution is the:

- dumping of urban waste matter messily;
- dumping of industrial waste, mineral exploitation;
- misusing the soil by harmful agricultural practices;
- visible litter and waste along with the soil itself being polluted.



The soil gets polluted by the chemicals in pesticides and herbicides used for agricultural purposes along with waste matter being littered in urban areas such as roads, parks, and streets.

Land Pollution Comprises Of:

(i) Solid Waste

It is waste created by human or animal activities that are disposed because they are hazardous or useless. Examples of solid wastes are paper, plastic containers, bottles, cans, used cars and electronic goods. They are not biodegradable, which means they do not get broken down through inorganic or organic processes. When this type of waste accumulates they pose a health threat to people. Rotting wastes also attract household pests and as a result urban areas becoming unhealthy, dirty, and unsightly places to live in. This also causes damage to terrestrial organisms and this also reduces the use of the land for other, more useful purposes.

Sources of solid waste are:

Wastes from Agriculture: These type of waste are matter that are produced by old crops, animal manure and farm residues.

Wastes from Mining: This can include piles of coal refuse and heaps of slag.

Wastes from Industries: Industrial waste can cause land pollution which include paints, chemicals, etc.

Solids from Sewage Treatment: Wastes that are left over after sewage has been treated, biomass sludge, and settled solids e.g. in Windhoek and Swakopmund.

Ashes: The remains after solid fuels are burned.

Garbage: This comprises of household waste matter from food that are decomposable and other waste matter that are not decomposable such as glass, metal, cloth, plastic, wood, paper, etc. It can also come from fast food shops and small businesses.

(ii) Soil Pollution

Soil pollution is mainly caused by chemicals in pesticides, such as poisons that are used to kill agricultural pests like insects and herbicides that are used to get rid of weeds. As a result of this soil pollution results from:

- unhealthy methods of soil management;
- harmful practices of irrigation methods.

Land pollution is mostly caused by farms because they allow manure to collect, which on the other hand leaches into the nearby land areas. Chemicals that are used for purposes like sheep dipping also cause serious land pollution. Another major contributor to soil pollution is diesel oil spillages.



In-text question

We have discussed land pollution and how it is caused, but do you think there are any consequences?

Harmful effects of land pollution

- Tonnes and tonnes of domestic wastes are dumped every day. Since people do not follow proper methods for the disposal of such wastes, it leaves the places look dirty and makes them unhealthy.
- Land pollution indirectly affects the respiratory system of human beings. Breathing in polluted dust or particle can result in a number of health problems related to the respiratory system.
- Skin problems are often diagnosed due to land pollution. It is said that the improper disposal of household wastes leads to allergic reactions on the skin.
- Land pollution has been found as one of the leading causes for birth defects. Pregnant women living in unhealthy and dirty environment can incur breathing problems and a number of diseases, which may affect the health of the baby as well.
- Land pollution has serious effect on wildlife. Flora, which provides food and shelter to wildlife, are destroyed.
- Land pollution often disrupts the balance of Nature, causing human fatalities.
- It can also cause various kinds of cancers

All the toxic materials that we have mentioned already that pollute the soil can get into the human body directly by:

- Coming into contact with the skin
- Being washed into water sources like reservoirs and rivers
- Eating fruits and vegetables that have been grown in polluted soil and
- Breathing in polluted dust or particles

This is a very serious matter, but are there any preventative measures? We will answer that question next.

How can land pollution be prevented?

For every problem there is a solution and it depends on us how we handle it. Next are some prevention ideas.

- People should be educated and made aware about the harmful effects of littering



- Items that are used for domestic purposes should be reused or recycled
- Personal litter should be disposed properly
- Organic waste matter should be disposed in areas that are far away from residential places
- Inorganic matter such as paper, plastic, glass and metals should be reclaimed and then recycled
- Measures should be in place to fine people who are found guilty of littering



In-text question

Can you think of any more prevention ideas? Discuss it with your friend or your parents.

Causes of Land Pollution

- Increase in urbanization is one of the major causes of land pollution. Construction uses up forestland. This leads to the exploitation and destruction of forests. There is more demand for water. Reservoirs are built resulting in the loss of land.
- The disposal of non-biodegradable wastes, including containers, bottles and cans made of plastic, used cars and electronic goods, leads to the pollution of land.
- Agricultural wastes including the waste matters produced by crop, animal manure and residues of the farm land are one of the major causes of land pollution. The pesticides and fertilizers used by farmers to increase the crop yield, leaches into the nearby land areas and pollutes them.
- The process of mining leads to the formation of piles of coal and slag. When these wastes are not disposed through proper channel, they are accumulated and contaminate the land.
- Industrial wastes are major contributors of land pollution. Dumping of toxic materials such as chemicals and paints makes the areas surrounding the industries, look very filthy.
- Improper treatment of sewage leads to the accumulation of solids, such as biomass sludge. These solid wastes overflow through the sewage, making the entire area look dirty.
- Burning of solid fuels leads to the formation of ashes, which is yet another cause of land pollution.
- Although domestic and industrial wastes are collected and recycled or burnt in incinerators, a large amount of rubbish is left untreated. These are then dumped into grounds, leading to land pollution.
- Garbage dumped by people makes the streets unhealthy, unfit and dirty to reside in. The waste matter usually consists of leftover food, fruit and vegetable peels and other non decomposable solid materials such as glass, cloth, plastic, wood, paper etc.

Let's do the next activity to test your knowledge on land pollution.

Activity



Activity

Time Required: In this activity you need at most 45 minutes to fully answer the question.

ADD ACTIVITY PLEASE



How long?

Once done with the activity, please compare your answers with mine before you proceed.



Feedback

Water pollution

Water pollution has been around ever since any of us can remember. What we need to look for now are water pollution solutions to help salvage our planet. So read on to know about some water pollution solutions...



Figure 3.15

Water pollution is a problem that isn't new to us. This type of pollution is a problem and has only recently struck environmentalists over the world. Some countries have strict laws to protect clean water; unfortunately, these laws haven't been followed up by adequate action. The EPA (Environmental Protection Agency) has declared 40% of lakes, streams and rivers unsafe for swimming and fishing. So now, along with prevention, there is a need to cure this problem as well. Let's look at a few water pollution solutions that each one of us can implement in our



own small way, because the fact is that, every drop makes an ocean.

Water Pollution Solutions

Charity Begins at Home

let's not start blaming other people for our own mistakes. Each one of us contributes to the damage that is done to our environment. So the best way to deal with it is to try and start with a change that may just turn into a revolution. How do we do that is the question?

- Start by checking any illegal setups of pipes that may be making waste flow from the nearest outflow pipe to the nearest water source.
- Try and help your own place and the neighbouring towns or cities to set up programs which will ensure periodic cleaning and maintenance of septic tanks.
- Save water. This will significantly help reduce the workload on the poor overworked septic systems.
- Don't buy plastic, as the plastic industry is actually blamed as being the main culprit when it comes to water pollution, as their chemicals and products which are dumped into the nearest river are non-biodegradable.

Enforcing Existing Laws

- Make water protection laws stricter and penalize anyone who's found breaking them.

Stop Deforestation

- All the different types of environmental pollution are inter related. Forests are the main source of absorbing rain water and soaking it up.
- Due to the broad spread of sprawling companies and residential complexes that is occurring at the cost of forests, leading to widespread deforestation, this entire mechanism of soaking in rain water comes to a grinding halt.
- Due to this, the rain water then gets diverted directly into streams, not only over exposing the soil, and taking away the fertile part of it, but also carrying pollution in the form of sediment with it.
- Therefore, one of the solutions for water pollution is simply to plant more trees.

Preventing Oil Spills

- The government can play an important role in this problem. How can we ask, but by simply regulating and inspecting the movement of commercial ships, and

- Educating citizens about the terrible consequences of this problem.
- Try and use transport that does not consume too much of petrol, like public transport.

Prevent Emissions

- Industrial water pollution isn't something that any of us are privy to, but one of the scariest discoveries of late has been the graveness of the fact that is known as mercury pollution.
- US power plants account for more than 40% of mercury emissions in the US.
- The phenomenon of mercury poisoning isn't new to us either. The solution to this problem is to prevent the amount of mercury pollution coming from land.
- We can implement one of the simplest water pollution solutions by simply preventing the amount of coal burning that is done, as this will significantly reduce the mercury pollution, that is occurring to such an extent that our marine ecosystem is being irreversibly harmed and damaged.
- Other problems, like acid rain can also be dealt with by preventing the amount of emissions coming from factories and production plants.

These were just a few of the possible solutions for water pollution.

Air pollution

Air pollution is the introduction of chemicals, particulate matter, or biological materials that cause harm or discomfort to humans or other living organisms, or cause damage to the natural environment or built environment, into the atmosphere.

The atmosphere is a complex dynamic natural gaseous system that is essential to support life on planet Earth. Stratospheric ozone depletion due to air pollution has long been recognized as a threat to human health as well as to the Earth's ecosystems.

Indoor air pollution and urban air quality are listed as two of the world's worst pollution problems in the 2008 Blacksmith Institute World's Worst Polluted Places report.

Types of air pollution

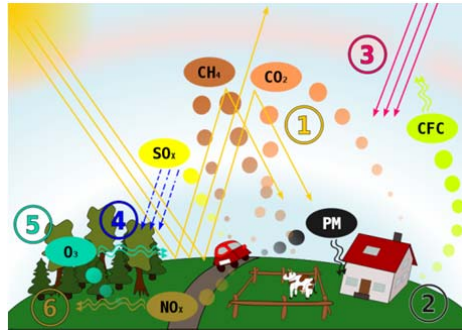

Figure 3.16 Source: http://en.wikipedia.org/wiki/Air_pollution

Air pollution solutions

Air pollution has many terrible effects that need to be limited. In order to achieve this, governments, scientists and environmentalists are using or testing a variety of methods aimed at reducing pollution.

There are two main types of pollution control.

Input control involves preventing a problem before it occurs, or at least limiting the effects the process will produce.

Five major input control methods exist. People may try to restrict population growth, use less energy, improve energy efficiency, reduce waste, and move to non-polluting renewable forms of energy production. Also, automobile-produced pollution can be decreased with highly beneficial results.

Output control, the opposite method, seeks to fix the problems caused by air pollution. This usually means cleaning up an area that has been damaged by pollution.

Input controls are usually more effective than output controls. Output controls are also more expensive, making them less desirable to tax payers and polluting industries.

Current air pollution control efforts are not all highly effective. In wealthier countries, industries are often able to shift to methods that decrease air pollution. In the United States, for example, air pollution control laws have been successful in stopping air pollution levels from rising. However, in developing countries and even in countries where pollution is strictly regulated, much more needs to be done.

Solutions to Air Pollution

To fight pollution in the United States, the Clean Air Act Amendments of 1970 gave the Environmental Protection Agency (EPA) the authority to establish and enforce air pollution standards and to set emission standards for new factories and extremely hazardous industrial pollutants. The states were required to meet "ambient air quality standards" by regulating the emissions of various pollutants from existing stationary sources, such as power plants and incinerators, in part by the installation of smokestack scrubbers, electrostatic precipitators, and other filters. Auto

manufacturers were mandated to install exhaust controls or develop less polluting engines. The Clean Air Act, as amended in 1977, authorized the EPA to impose stricter pollution standards and higher penalties for failure to comply with air quality standards.

In 1990 when the act was reauthorized it required most cities to meet existing smog reduction regulations by the year 2005. The 1990 amendments also expanded the scope and strength of the regulations for controlling industrial pollution. The result has been limited progress in reducing the quantities of sulphur dioxide, carbon monoxide, nitrogen oxide, ozone, particulate matter, and lead in the air. The EPA also regulated hazardous air pollutants, which in 1992 included mercury, beryllium, asbestos, vinyl chloride, benzene, radioactive substances, and inorganic arsenic.

The most satisfactory long-term solutions to air pollution may well be the elimination of fossil fuels and the ultimate replacement of the internal-combustion engine. To these ends efforts have begun in the United States, Japan, and Europe to develop alternative energy sources, as well as different kinds of transportation engines, perhaps powered by electricity or steam. A system of pollution allowances based on trading emission rights has been established in the United States in an attempt to use the free market to reward pollution reductions, and the international sale of surplus emission rights is permitted under the Kyoto. Other proposed solutions include raising electricity and gasoline rates to better reflect environmental costs and to discourage waste and inefficiency, and mechanical controls on coal-fired utility plants.

In 1992, 150 nations signed a treaty on global warming at the UN-sponsored summit on the environment in Rio de Janeiro. A UN Conference on Climate Change, held in Kyoto, Japan, in 1997, produced an international agreement to combat global warming by sharply reducing emissions of industrial gases. Although the United States abandoned the treaty in 2001, saying it was counter to U.S. interests, most other nations agreed that year on the details necessary to make the protocol a binding international treaty, and the necessary ratifications brought the treaty into force in 2005.



Case Study



Case Study / Example

Air pollution from Van Eck station 'OK'

By: BRIGITTE WEIDLICH

THE thick, black smoke rising from the coal-fired Van Eck power station in Windhoek for the past few weeks is no health risk, and within the acceptable limits of the World Health Organisation (WHO), says NamPower.

"NamPower took cognisance of the complaints by residents and businesses in proximity of that power station and understand their fear for possible health risks that the emissions can pose," a NamPower advertisement placed in newspapers yesterday stated. Instead of calling a press conference to address these complaints, the company's new Corporate Communications and Marketing Manager, John Kaimu, placed a small-print advertisement to state NamPower's case.

The chimneys at Van Eck have no pollution filters. Namibia also does not have any laws to regulate the emissions from factories and power stations. NamPower had to switch on the Van Eck power station a few weeks ago due to problems at Koeberg nuclear power plant in South Africa, from where Namibia receives about half of its electricity supply.

Koeberg has two units generating 900 megawatt of power each, but one of them was damaged about two years ago by a loose eight-centimetre-long bolt was apparently forgotten after routine maintenance. This caused severe power cuts in South Africa. A new turbine had to be imported from France and was installed. After that was done, the intact unit had to undergo an overhaul for about three months. According to the NamPower advertisement, one of the two Koeberg units is again out of operation - until the end of this month. The other Koeberg unit will be offline again for three months from January 2008, according to the NamPower advertisement. This has necessitated NamPower to keep the Van Eck power station running even longer, before putting it back on standby mode.

"In an effort to minimise smoke from Van Eck, a budget has been set aside to overhaul the cyclones of the power station. It does not have filters but makes use of cyclones," the advertisement said. "Once completed, we expect a significant reduction in the carbon dioxide emissions and fall-out dust levels." Instead of calling a press conference to address these complaints, the company's new Corporate Communications and Marketing Manager,

John Kaimu, placed a small-print advertisement to state NamPower's case. The chimneys at Van Eck have no pollution filters. Namibia also does not have any laws to regulate the emissions from factories and power stations.

NamPower had to switch on the Van Eck power station a few weeks ago due to problems at Koeberg nuclear power plant in South Africa, from

where Namibia receives about half of its electricity supply. Koeberg has two units generating 900 megawatt of power each, but one of them was damaged about two years ago by a loose eight-centimetre-long bolt was apparently forgotten after routine maintenance. This caused severe power cuts in South Africa. A new turbine had to be imported from France and was installed. After that was done, the intact unit had to undergo an overhaul for about three months. According to the NamPower advertisement, one of the two Koeberg units is again out of operation - until the end of this month. The other Koeberg unit will be offline again for three months from January 2008, according to the NamPower advertisement. This has necessitated NamPower to keep the Van Eck power station running even longer, before putting it back on standby mode."In an effort to minimise smoke from Van Eck, a budget has been set aside to overhaul the cyclones of the power station. It does not have filters but makes use of cyclones," the advertisement said."Once completed, we expect a significant reduction in the carbon dioxide emissions and fall-out dust levels."

Adapted from:

[http://www.namibian.com.na/index.php?id=28&tx_ttnews\[tt_news\]=40388&no_cache=1](http://www.namibian.com.na/index.php?id=28&tx_ttnews[tt_news]=40388&no_cache=1)

Resources

Reference

Moore, J. K. (2010). <http://allafrica.com/stories/201002251315.html>

<http://www.biocab.org/overpopulation.html>

<http://en.wikipedia.org/wiki/Overpopulation>

<http://www.buzzle.com/articles/land-pollution.html>

<http://www.buzzle.com/articles/causes-of-overpopulation.html>

<http://lifestyle.iloveindia.com/lounge/causes-and-effects-of-land-pollution-4470.html>

<http://www.buzzle.com/articles/water-pollution-solutions.html>

[http://www.namibian.com.na/index.php?id=28&tx_ttnews\[tt_news\]=40388&no_cache=1](http://www.namibian.com.na/index.php?id=28&tx_ttnews[tt_news]=40388&no_cache=1)

<http://www.infoplease.com/ce6/sci/A0856527.html>

http://library.thinkquest.org/26026/Environmental_Problems/air_pollution_-_solutions.html

http://en.wikipedia.org/wiki/Air_pollution



Unit summary



Summary

In this unit you learned what is ‘deforestation’?

An area is deforested when people cut down trees faster than what they can be replaced.

Trees are also important because:

- they form a natural habitat for birds and insects
- they provide fruit to animals and people
- they provide shade to animals and people
- their roots, leaves, bark and sap can be used to make medicine

More reasons for clearing vegetation include:

- using wood for heating purposes
- to plant crops
- for cattle ranching
- to expand towns and cities
- for mining purposes
- for road building
- to build hydro-electric power stations

In certain parts of the world slash and burn methods are practised. Trees are burned to clear large areas for crop production.

But sometimes natural factors can cause deforestation. This is when deforestation occurs due to natural factors, which are beyond human control. Natural causes of deforestation include:

- Drought
- Very little rainfall
- Natural forest fires

What is ‘desertification’?

- ‘Desertification’ occurs when previously vegetated and productive land turns into a desert-like area due to overuse of land. This means that land becomes degraded

Overpopulation is a term that refers to a condition by which the population density enlarges to a limit that provokes the environmental deterioration, a remarkable decline in the quality of life, or a population collapse.

The term population density refers to the number of people in a specific area, for example: 100 people per square kilometre.

Land pollution occurs everywhere and it is an ugly site to see and to think of it, it is us who are responsible for that.

Soil pollution is mainly caused by chemicals in pesticides, such as poisons that are used to kill agricultural pests like insects and herbicides that are used to get rid of weeds.

Air pollution is the introduction of chemicals, particulate matter, or biological materials that cause harm or discomfort to humans or other living organisms, or cause damage to the natural environment or built environment, into the atmosphere.

Assignment



Assignment

Ecology

- (a) Write down a suitable term for each of the descriptions below:
- The replacement of grasslands by scrubs and bushes. (1)
 - The gradual increase in average global temperature. (1)
 - When the natural resources available in a country can no longer sustain the growing population. (1)
 - The method of grazing by which farmers let their stock graze alternatively in different camps during the year. (1)
 - The gas in the atmosphere which is able to absorb and filter out the dangerous ultraviolet radiation from the sun. (1)
- (b) Study the figure below which shows some of the causes of deforestation.

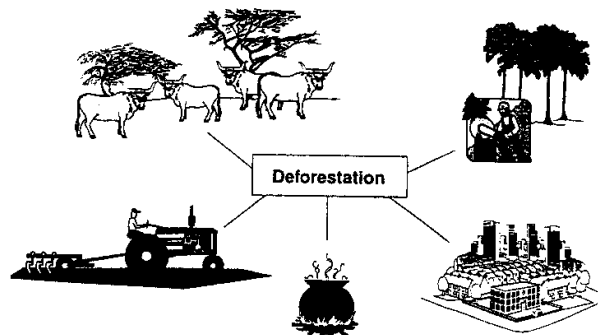

- Define the term deforestation. (1)
 - Suggest two reasons from the above figure why more and more forestland is being cleared. (2)
 - Suggest two possible solutions to reduce deforestation. (2)
- (c) Study the flow diagram below that shows how desertification takes place in a developing country.

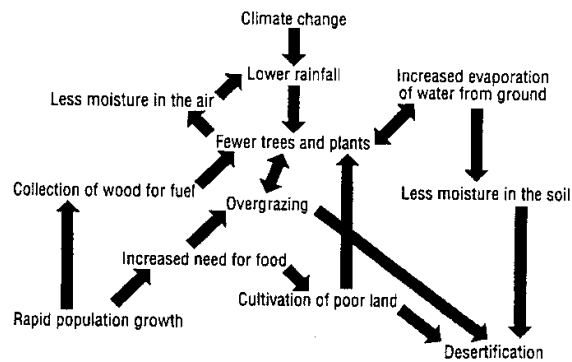

- (i) Distinguish between desertification and desertisation. (2)
- (ii) From the above diagram write down:
- (aa) one natural cause of desertification. (1)
- (bb) one man-made cause of desertification. (1)
- (iii) Describe how overgrazing can cause desertification. (1)

(d) The diagram below shows how a rural community uses a river.



- (i) Write down one way in which people make use of the river. (1)
- (ii) State two ways in which the river is being polluted. (2)
- (iii) Suggest how the people can be convinced to stop polluting the water. (2)
- (e) (i) State what is meant by overpopulation. (1)
- (ii) Suggest two indicators which show that a country is overpopulated. (2)
- (iii) Suggest two possible solutions to reduce overpopulation. (2)
- (iv) Write down one natural resource in Namibia which comes increasingly under pressure as a result of rapid population growth. (1)

Total: 25



Assessment Feedback



Assessment

Ecology

- (a) (i) Bush encroachment (1)
 (ii) Global warming (1)
 (iii) Overpopulation (1)
 (iv) Rotational grazing (1)
 (v) Ozone layer (1)
- (b) (i) Deforestation means the cutting down of trees faster than they can grow back or be replanted. (1)
 (ii) Plantation
 Timber
 Expansion of towns and cities
 Source of fuel for cooking purposes (2)
 (iii) Use alternative energy sources, e.g. solar energy.
 Use alternative building material e.g., bricks.
 Reforestation
 Recycling (2)
- (c) (i) Deforestation is the process caused by people, while desertification is the process caused by nature. (2)
 (ii) (aa) lower rainfall (1)
 (bb) overgrazing (1)
 (iii) Contributed to fewer plants and trees until nothing is left, the topsoil is blown away, increased soil erosion which contributes to desertification. (1)
- (d) (i) Washing clothes/dishes
 Bathing (1)
 (ii) Livestock drink in the river
 Washing of dishes (2)
 (iii) Provide taps to the people
 Build a separate channel for livestock to drink water
 Educate people about personal hygiene
 Awareness campaigns
 Cook the water before drinking it (2)

	(e) (i) Overpopulation means that the natural resources available in the country can no longer sustain the number of people in the country (1)
	(ii) Unemployment
	Famine
	Poverty
	A lot of children (2)
	(iii) Improved status of women
	Emancipation of women
	Family planning methods (2)
	(iv) Pressure on water, food and fuel
	Pressure on land because of demand for fuel (1)
	Total: (25)

Unit 4

Geomorphology

Introduction

Welcome to unit 4 which deals with geomorphology. Geomorphology is the study of the physical (natural) features of the surface (crust) of the earth and the forces that affect it from both inside and outside the earth. Therefore, in this unit we will explain everything on the basis of the following objectives.

Upon completion of this unit you should be able to:



Outcomes

- *explain* the causes of plate movements;
- *differentiate* between divergent, convergent and neutral plate boundaries;
- *identify* from sketches landforms like mid-oceanic ridges, deep-sea trenches and volcanic island archs;
- *explain* the relation between plate movements and fold mountains;
- *identify* different types of folds on sketches and photographs;
- *identify* fold mountain ranges on a world map;
- *understand* the relation between plate movements and earthquakes;
- *identify* the global distribution of earthquakes on a world map
- *identify* the causes of earthquakes and determine their impact on people;
- *explain* the relation between plate movements and volcanoes;
- *identify* the global distribution of volcanoes on a world map;
- *identify* what causes volcanoes and draw a simple sketch of a volcano;
- *explain* their impact on people and the environment;
- *differentiate* between weathering and erosion;
- *distinguish* between mechanical, chemical and biological weathering;
- *recognise* the agents of erosion, such as running water, wind and moving ice;
- *identify* the landforms created by weathering and erosion.



Terminology

Earthquake focus:	The exact point in the crust where an earthquake has started.
Epicentre of an earthquake:	The point on the surface of the earth, directly above the focus.
Seismograph:	The instrument used to record the strength and direction of an earthquake.
Seismogram:	The record drawn by a seismograph.
Weathering:	The breaking up of sediments on the surface of the earth, with no movement involved.
Erosion:	The process whereby weathered material is removed from its place of origin to new locations.
Erosion agents:	The elements that remove weathered material, e.g., wind, water, ice.
Deposition:	When eroded materials are put down in new locations.
Tectonic plate:	A huge section of the earth's crust that floats on the mantle.
Plate boundaries:	The edges of plates.
Subduction zone:	The zone where a denser oceanic plate sinks underneath a less dense continental plate. The oceanic plate is forced into the mantle.
Constructive plate boundary:	Where plates are pulling apart or moving away from each other.
Destructive plate boundary:	Where an oceanic and continental plate moves to each and collide.
Shear plate boundary:	Where plates slide past each other in opposite directions.

Section 1 Endogenic (internal) forces

Let's start this unit and section with an explanation of endogenic (internal) forces. We can however ask a question like what are internal forces? But wait seeing that we are starting with geomorphology we should then answer that question. Geomorphology is the study of the physical features of the surface of the earth and their relation to its geological structures. In this section we will however only look at the internal forces. But wait you should study the outcomes first to familiarize yourself with what is expected of you in this section.



Section outcomes

By the end of this section you should be able to:

- *explain* the causes of plate movements;
- *differentiate* between divergent, convergent and neutral plate boundaries;
- *identify* from sketches landforms like mid-oceanic ridges, deep-sea; trenches and volcanic island archs.

Continental drift

We will first explain continental drift. Several Geologists explored the idea since the 19th and early 20th century that the continents may have moved across the Earth's surface. They were all inspired by the remarkable fit between the Atlantic coasts of Africa and South America. The hypothesis of continental drift was largely developed by the German Alfred L. Wegener, a lecturer in astronomy and meteorology, who suggested that the Earth's continents had at one time been joined in two supercontinents. In the year 1912, Wegener made the proposal that all the continents were previously one large continent, but then broke apart, and had drifted through the ocean floor to where they are now located. Apart from using the fit of the two continents already mentioned, Wegener also used fossil distribution and lithological similarity as evidence.

Using this evidence, he joined all of the southern continents, together with India, into a supercontinent which he named *Pangea*. Instead of a simple supercontinent, Du Toit reconstructed the continents at the South Pole and grouped the northern continents near the Equator. He called his southern supercontinent Gondwanaland and the northern land mass Laurasia. He devoted most of his book to Gondwanaland and as evidence for its existence he produced an impressive mass of data far more detailed than anything Wegener had attempted.

Plate Tectonics

According to the plate tectonic model, the surface of the Earth consists of a series of relatively thin, but rigid, plates which are in constant motion. The surface layer of each plate is composed of oceanic crust, continental crust or a combination of both. The lower part consists of the rigid upper layer of the Earth's mantle. The rigid plates pass gradually downwards into the plastic (soft) layer of the mantle, the asthenosphere. The plates may be up to 70 km thick if composed of oceanic crust or 150 km incorporating continental crust. Plates move at different velocities, The African plate moves about 25 mm per year, whereas the Australian plate moves about 60 mm per year.

Most of the Earth's tectonic, seismic and volcanic activity occurs at the boundaries of neighbouring plates. There are three types of plate boundaries: divergent, convergent and shear/neutral/transform boundaries. We are going to look at the different types of plates and what causes plates to move.



What causes plates to move?

Four main hypotheses have been put forward to explain this movement. This hypothesis suggests that the flow in the mantle is induced by **convection currents** which drag and move the lithospheric plates above the asthenosphere. Convection currents rise and spread below divergent plate boundaries and converges and descends along convergent plates. Three sources of heat produce the convection currents and they are:

- (1) cooling of the Earth's core;
- (2) radioactivity within the mantle and crust; and
- (3) cooling of the mantle.

Types of Plate Margins

By now you know that there are three types of plate margins and we will discuss them separately with example of landforms associated with these types of margins.

A. Divergent Margins: plates move away from one another. There is an evolution in the development of a divergent margin. The following landforms are formed:

- 1. Continental rift:** upwelling mantle heats bottom of continental lithosphere and this on the other hand may apply extensional stress. A typical example is the formation of a rift valley.
- 2. New ocean basin:** formation of oceanic lithosphere marks the creation of 2 plates where formerly 1 had existed.

B. Convergent margins: plates move toward one another. There are three basic types, depending upon the types of lithosphere involved and they are:

- 1. Subducting margins:** oceanic crust is pushed beneath an nearby plate, resulting in volcanism when the plate reaches 100 km.
 - a. Two oceanic plates** results in the formation of oceanic island arcs, and very deep trenches. An example is the (Marianas trench where Pacific plate descends beneath Philippines plate is -11040 m).
 - b. Oceanic and Continental Plates** where the Oceanic plate descends beneath Continental Plate. An example is the subduction of the Nazca Plate beneath South America.

2. Collisional margins. Here it involves the collision of two continental plates after an ocean basin is consumed by subduction. Partial subduction of one continental plate forms thick crust and generation of tremendous topography by isostasy (Mt. Everest is 8853 m). Here we can use the example of the collision of the India and Eurasian plates and the Iberian and Eurasian plates.

The last margin that we are going to look at is the transform/shear margins.

C. Transform/shear margins. Plates move past one another on transform faults that cut through the lithosphere. They may have features locally of either extension or shortening, because plate movement may not be exactly parallel to the continental margin. An example is the San Andreas Fault.



In-text question

What landforms do you think can be formed at these plate boundaries or island only being destroyed? Share your view with your friend.

Landforms Associated with Plate Boundary Activity

Fold Mountains

Fold Mountains are:

- upland areas formed by the buckling of the earth's crust - associated with convergence boundaries (destructive and collision margins)
- formed at destructive margins and it occur where oceanic crust is subducted underneath the continental plate, forcing the over-riding plate to crumple and uplift - the resulting folding and faulting results in the formation of a mountain chain roughly parallel to the oceanic trench - e.g. the Andes Mountains.
- collision zones and occur as the colliding plates resist subduction and uplift occur with folding and faulting - e.g. the Himalayas.



Figure 4.12

Oceanic Trenches

- These are often found in a linear pattern located just offshore;
- Deep oceanic trenches form at destructive margins where oceanic lithosphere is subducted into the asthenosphere below;
- the long and narrow oceanic trenches are formed during and mark the place where the ocean floor is deepest (about 10km below sea level);
- Example - the collision of the Nazca plate and South American plate has produced the Peru-Chile deep sea trench off the west coast of South America.

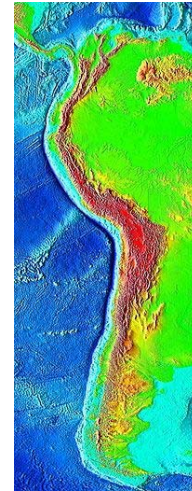

Figure 4.13

Source: http://en.wikipedia.org/wiki/Peru-Chile_Trench

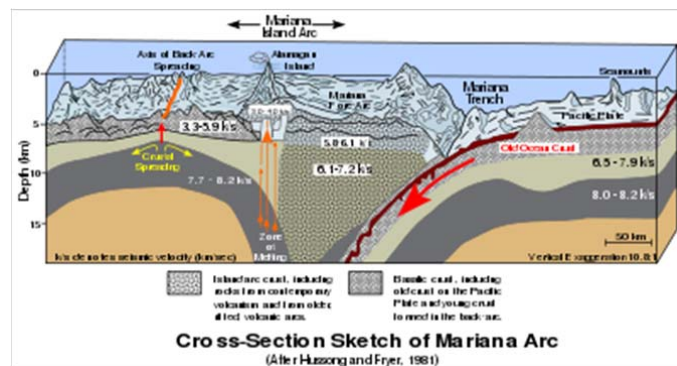

Figure 4.14

Source: http://en.wikipedia.org/wiki/Mariana_Trench

Island Arcs

- like oceanic trenches, these tend to form a linear pattern, although one which is "arc-shaped";
- an island-arc is a chain of volcanic islands that form at a destructive boundary where there is the convergence of two oceanic plates;
- during subduction, the subducting plate is melted (due to interior heat, friction and pressure) and creates a magma source;
- the light, less dense magma rises to the surface and erupts to form submarine volcanoes;
- eventually these volcanoes grow through successive eruptions to above the height of sea-level forming a chain of volcanic islands which is known as an island-arc.

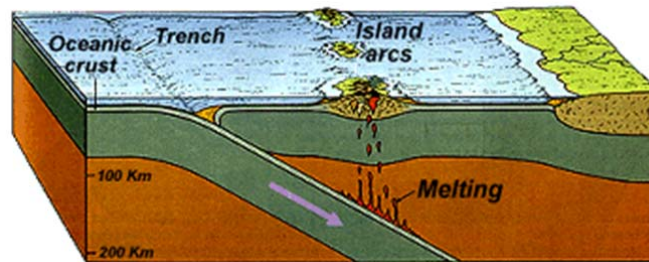

Figure 4.15

Source: Google images

Ocean Ridges

- These are underwater mountain ranges which develop where divergence takes place (as two plates move apart);
- Ocean ridges, occur in a linear pattern, usually through the middle of oceans (e.g. the Mid-Atlantic Ridge);
- As magma rises at this point (the rising limb of a convection cell), the rising magma causes the lithosphere to dome up creating the ridge and where tensional forces, creates weaknesses in the crust, magma erupts forming volcanoes which further build up the ridge;
- The East-Pacific Ridge is an anomaly from the pattern of mid-ocean ridges - which can be explained by the fact that the rising limb of the convection cells in the asthenosphere is located in this position.

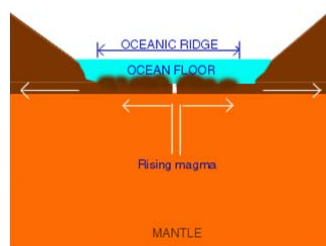

Figure 4.16

Source: <http://library.thinkquest.org/22752/Sea%20Structure/Ridge.html>

Now do activity 1

Activity 1



Activity

Time Required: In this activity you need at most 45 minutes to fully answer the question.



How long?

1. The following are all types of plate boundaries except
2. Continental crust is
3. At a divergent plate boundary...
4. The zone where one plate slides under another is called the
5. When two oceanic plates collide a (n) _____ is formed.
6. The lithosphere is made up of
7. When looking at mid ocean ridges, the oldest rocks are

Once done with the activity, please compare your answers with mine before you proceed.



Feedback

Section 2

Fold Mountains

If you take a piece of paper and apply compressive force from both sides or simply just from the other side then you are folding the piece of paper. But wait before we let the cat out of the bag let's study the section outcomes first.

By the end of this section you should be able to:

- *explain* the relation between plate movements and fold mountains;
- *identify* different types of folds on sketches and photographs;
- *identify* fold mountain ranges on a world map.



Section outcomes

Fold Mountains

Remember the piece of paper that I mentioned in the introduction. Let's continue by explaining that Fold Mountains are actually formed by crust (the upper layer of the internal structure) which have been uplifted and folded by compressional forces. Compressional force means a force or pressure that attempts to flatten or squeeze a material. Now we can ask

the question, but where is this taking place. This type of force occurs along convergent plate boundaries where two plates move towards each other, that means converging plates. This can happen between continental plates or between an oceanic and a continental plate. The crust and the rocks bent and crumpled and massive layers of Earth's crust gets uplifted as a result, forming spectacular fold mountains.

This is correct, it happened on earth and there are visible examples to support this. Well-know examples of Fold Mountains are the Himalayas in Asia and the Andes in South America.

Below is an example of different types of folds, but we will discuss them in more detail.

Types of folds

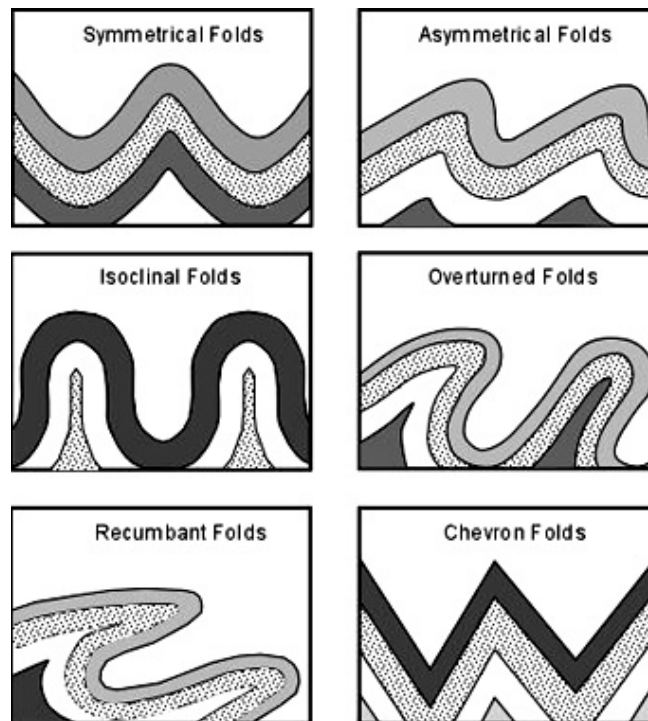

Figure 4.17

How are Fold Mountains formed?

Fold Mountains can either be formed when:

- two continental plates move towards each other or;
- a continental plate move towards an oceanic plate.

The movement of the two plates forces sedimentary rocks into a series of folds. Fold Mountains are usually formed from sedimentary rocks and are usually found along the edges of the continents. When plates collide the

accumulated layers of rock crumple and form a series of Fold Mountains. Remember that collide means to bump, run or crash into one another.

There are also two types of Fold Mountains:

- young fold mountains (10 to 25 million years of age, e.g. Rockies and Himalayas); and
- old fold mountains (over 200 million years of age, e.g. Urals and Appalachians of the USA).

Table 1 Showing types of folds

Description	Example
<p>Earth movements cause sedimentary rocks to be displaced i.e. to be pushed out of the horizontal plane so that the rocks are tilted or inclined.</p> <p>Earth movements can also cause folding and faulting of the sedimentary rocks. Folding results from lateral forces (compressional forces).</p> <p>Lateral forces of compression cause folding while either lateral or vertical forces of tension or compression cause faulting.</p>	
<p>The nature of folds</p> <p>The layers of rock which bend up form an up fold or anticline. Those which bend down form a down fold or syncline. The sides of a fold are called the limbs .if compression continues the simple folds are changed first to a symmetrical folds, then into over folds and finally into over thrust folds.</p>	
<p><u>Simple/Symmetrical fold</u> This type of fold has two limbs of <i>equal steepness</i>. It results when the two opposing forces moving towards each other are of equal strength.</p>	

<p><u>Asymmetrical fold</u></p> <p>This fold has one limb steeper than the other. It results when one opposing force is greater than the other.</p>	
<p><u>Overtaken fold</u></p> <p>This fold has one limb pushed over the other limb, until the axis of fold is almost horizontal and the two limbs are almost parallel. This is formed when one opposing force is very much greater than the other.</p>	
<p>Note: Fold Mountains can be found in the North West Africa i.e. Atlas Mountains and in South Africa i.e. Cape Ranges.</p> <p><u>Influence of Fold Mountains on human activities</u></p> <p>Fold Mountains often receive heavy rain or heavy snow falls which may give rise to important rivers. For example the Alps in Europe.</p> <p>NB: The process of folding was not significant in East Africa and therefore didn't create any significant land forms.</p>	

Table 1

Source: <http://www.elateafrica.org/elate/geography/earthmovements/earthmovementsintro.html>

Asymmetrical fold

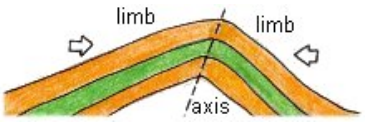
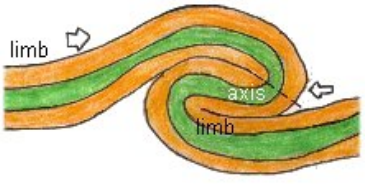
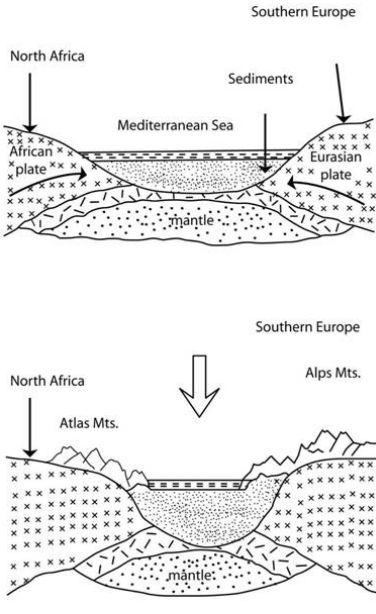
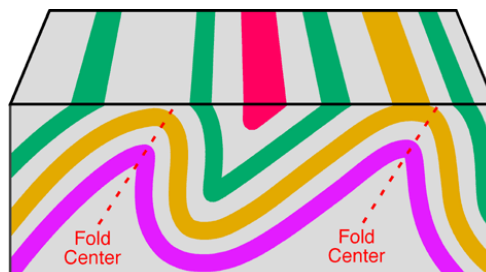

Figure 4.18

Source: <http://www.physicalgeography.net/fundamentals/101.html>

Fold mountain formation

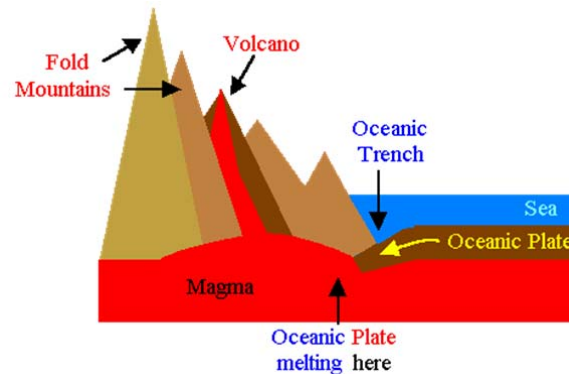

Figure 4.19
Source:

Folding

When rocks deform by plastic deformation they can bend and fold. The process of **folding** occurs when rock is compressed, as it is along colliding plate boundaries. Uprturned folds are called **anticlines** (as shown below in figure 4.20) and down turned folds are called **synclines**. Anticlines and synclines are geologic structures, that is, they are folds in rock material. The sides of the fold between the anticline and syncline are called the **limbs**. Each fold has an **axial plane**, an imaginary plane that runs down its length and divides the fold in half.

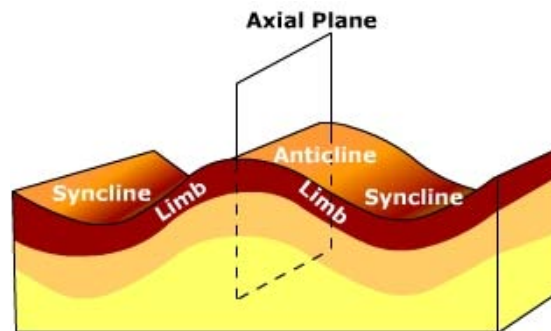

Figure 4.20
http://www.uwsp.edu/geo/faculty/ritter/geog101/textbook/tectonics_landforms/folding.html



In-text question

Will you be able to explain the different types of folds?

Fold Mountain distribution

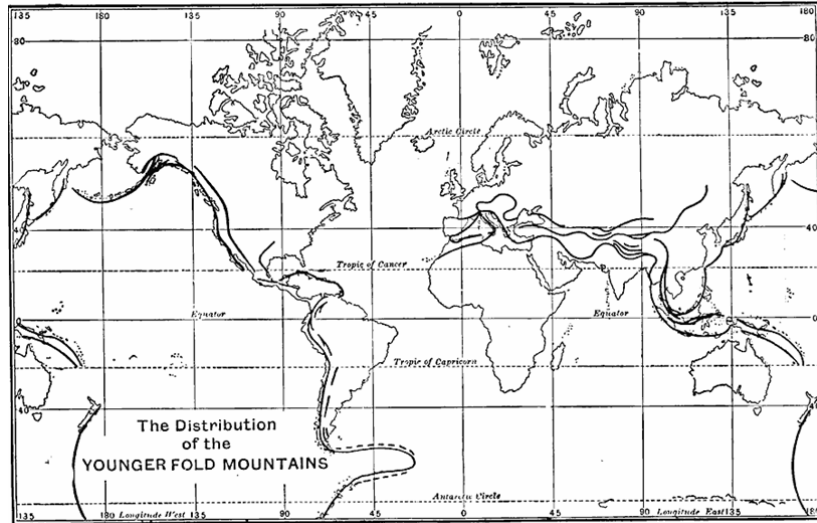

Figure 4.21

Source: <http://etc.usf.edu/maps/pages/3600/3636/3636.htm>

Now try the following activity to assess your understanding of fold mountains.

Activity 2



Activity



How long?

Time Required: In this activity you need at most 45 minutes to fully answer the question.

Once done with the activity, please compare your answers with mine before you proceed.



Feedback



Section 3 Earthquakes

To give a short description of an earthquake we can say the shaking and vibration at the surface of the earth resulting from underground movement along a fault plane or from volcanic activity. This is how an earthquake can be described, but before we continue I want you to study the unit outcomes first.

By the end of this section you should be able to:



Section outcomes











A scientist who studies earthquakes is called a seismologist.





- *indicate* on a map the global distribution of earthquake zones;
- *explain* the causes of earthquakes;
- *explain* the relationship between plate tectonics and earthquakes;
- *explain* the impacts of earthquakes on civilization.

We often hear about earthquakes that have occurred in different parts of the world. Can you think of any recent earthquakes?

Look at the list of earthquakes that only occurred during January 2011 taken from Wikipedia, the free encyclopedia.

January 2011

-  Santiago del Estero Province, Argentina was struck by a magnitude 7.0 earthquake that occurred on January 1. At a depth of 583.6 km, shaking was weak and was not strongly felt.
-  Araucanía Region, Chile was struck by a magnitude 7.1 earthquake that occurred on January 2.
-  Loyalty Islands, New Caledonia was struck by a magnitude 6.3 earthquake that occurred on January 5.
-  South of Iran was struck by a magnitude 5.4 earthquake that occurred on January 5, injuring 16 and damaging homes.
-  Vanuatu was struck by a magnitude 6.6 earthquake that occurred on January 9.
-  Vanuatu was struck by a magnitude 6.1 earthquake on January 9, this followed an earlier 6.6 earthquake.
-  Bonin Islands was struck by a magnitude 6.5 earthquake that occurred on January 12.
-  Loyalty Islands, New Caledonia was struck by a magnitude 7.0 earthquake that occurred on January 13.
-  Southern Sumatra, Indonesia was struck by a magnitude 6.0 on January 17.
-  Southwestern Pakistan, 45 km west of Dalbandin, was struck by a magnitude 7.2 earthquake that occurred on January 18.
-  Tajikistan was struck by a magnitude 6.1 earthquake that occurred on January 24.

-  Simeulue was struck by a magnitude 6.1 earthquake that occurred on January 26.
-  Southeastern Iran was struck by a magnitude 6.2 earthquake that occurred on January 27.
-  Jan Mayen island region was struck by a magnitude 6.2 earthquake that occurred on January 29.
-  Tonga was struck by a magnitude 6.0 earthquake that occurred on January 31.

Isn't it amazing that so many earthquakes have occurred in one month only? Earthquakes can cause extensive damage and disrupt the lives of people and the economy of a country. That is why it is so important that people learn more about earthquakes in order to protect themselves from future earthquakes.

Now find the locations of the earthquakes listed above on the map below. What do these locations have in common? Yes, they are located along plate boundaries. Now let us study the map below which shows us where in the world earthquakes are found.

Global distribution of earthquakes

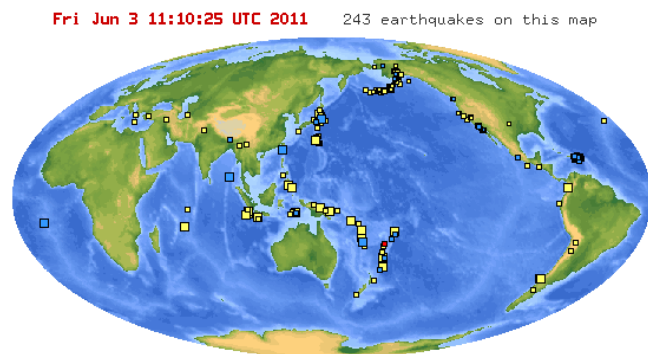

Figure 4.22

http://earthquake.usgs.gov/earthquakes/recenteqsww/Maps/world_moll/world_moll.gif

By carefully studying the map we can describe the global distribution of earthquakes as follows:

Earthquakes occur

- along plate boundaries (destructive, collision and shear)
- along the whole length of the Mid-Atlantic Ocean ridge
- along the boundaries of the Pacific plate which makes up the Pacific Ring of Fire

So does it mean that earthquakes do not occur in areas further away from plate boundaries?

No, it is not entirely true. Sometimes tremors can be felt very far away from the origin of an earthquake.

Minor earthquakes also occur along minor fault lines. Let us look at Windhoek, for example. Windhoek and Namibia in general, is situated far away from plate boundaries. However, some earthquakes have occurred in Windhoek.

19.10.2005

Light earthquake recorded in Windhoek

By: Absalom Shigwedha

A light earth tremor was felt in some parts of Windhoek around noon on Friday, the Department of Geological Survey in Ministry of Mines and energy confirmed yesterday.

Seismologist Azangi Mangongolo told The Namibian that the earthquake's epicentre was about seven kilometres east of Windhoek. He said the quake measured 3 on the Richter scale and was felt in areas such as Northern Industrial Area, Rocky Crest, Khomasdal and Hochland Park.

"Some people in Rocky Crest who were in a shop said they saw things falling and shaking in the shop," said Mangongolo.

(An extract from The Namibian, 19 September 2010)

How are earthquakes formed?

An earthquake is a sudden shake in the earth's crust, caused by the movement of tectonic plates. It is sometimes accompanied by a very loud noise or rumbling which sounds terrifying. Earthquakes mostly occur along collision, destructive and shear plate boundaries.

As two plates collide against each other, or move past each other, the jagged edges of the plates hook onto each other. Friction occurs as the plates collide into each other. As these plates are now stuck against each other they continue to move in opposite directions. Pressure and large amounts of energy build up and when the hooked rocks snap, the energy is released very suddenly. The energy travels in the form of shock waves or seismic waves. Seismic waves are the strongest at the point where the earthquake originates.

Let us look at the diagram below.

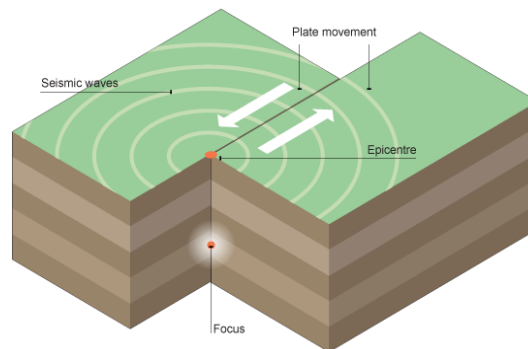

"On average, each year there are 17 earthquakes of magnitude 7.0 to 7.9 and one quake above magnitude 8.0"

Matt Rosenberg - About.com

Figure 4.23

http://www.bbc.co.uk/schools/gcsebitesize/geography/images/tec_007.gif

In the diagram above two plates are sliding along each other in opposite directions. The point inside the crust where the earthquake originates is

called the **focus**. The point on the surface of the earth, directly above the surface is called the **epicenter**.

The energy released by an earthquake travels through the crust and is felt as **seismic waves**, which spread out in all directions from the epicenter. As the seismic waves travel further from the epicenter they become less strong, meaning the ground shakes less. Thus the impact of an earthquake is greater at the epicenter.

Earthquakes could result in devastating effects such as many deaths, destroy settlements and change landscapes.

How is the strength of an earthquake measured?

The intensity of an earthquake is measured on a Richter Scale, which is not an instrument, but a logarithmic scale, which ranges from 1 - 10. The magnitude (strength) of an earthquake is determined from the readings of the seismic waves caused by the earth's vibrations. Earthquakes that are not generally felt by humans are called 'micro-earthquakes. They are only detected by seismographs and could register 2.0 or less on the Richter scale. With every whole point the magnitude rise, the strength of the waves increases by ten times. This means that an earthquake with a magnitude of 6 is ten times stronger than an earthquake with a magnitude of 5. (Refer to the Richter scale below.) Seismic waves with a magnitude of 8.0 or more is considered a 'great earthquake.'

Let us now look at the Richter scale below:

The left column shows the magnitude. The right column shows how the earthquake could be experienced by people.

Richter Magnitude	Feels like KG of TNT	Extra Information
0-1	0.6-20 kilograms of dynamite	We can not feel these.
2	600 kilograms of dynamite	Smallest quake people can normally feel.
3	20,000 kilograms of dynamite	People near the epicenter feel this quake.
4	60,000 kilograms of dynamite	This will cause damage around the epicenter. It is the same as a small fission bomb.
5	20,000,000 kilograms of dynamite	Damage done to weak buildings in the area of the epicenter.
6	60,000,000 kilograms of dynamite	Can cause great damage around the epicenter.
7	20 billion kilograms of dynamite	Creates enough energy to heat New York City for one year. Can be detected all over the world. Causes serious damage.
8	20 billion kilograms of dynamite	Causes death and major destruction. Destroyed San Francisco in 1906.
9	20 trillion kilograms of dynamite	Rare, but would causes unbelievable damage!

Table 2

Now let us look at the seismographs below:

A seismograph is the instrument used to record the force and direction of an earthquake by detecting the vibrations that travel through the crust of the earth.

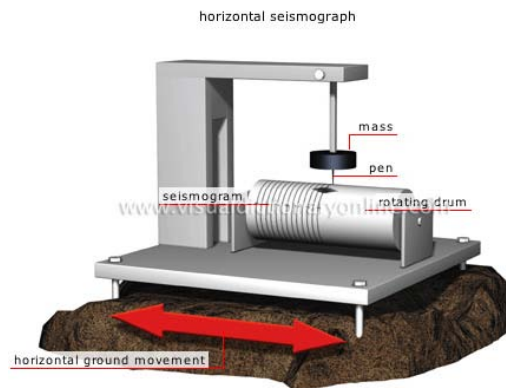

Figure 4.24

http://visual.merriam-webster.com/images/earth/geology/earthquake/seismographs_2.jpg

A seismograph consists of mass which remains stationary during an earthquake, thus serving as a reference for measuring the amplitude of tremors. A pen is attached to the mass. The pen draws a graph (consisting of oscillations moving up and down) on graph paper, which is attached to a rotating drum. The rotating drum rotates under the pen, recording ground movements on paper. The graph drawn by the pen is called a seismogram. The stronger the vibrations of the ground, the greater are the oscillations.

Below is a photograph of a seismograph, with an example of a seismogram.

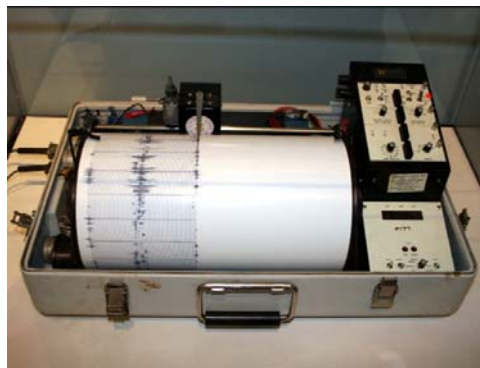

Figure 4.25

Source: http://commons.wikimedia.org/wiki/File:Kinematics_seismograph.jpg

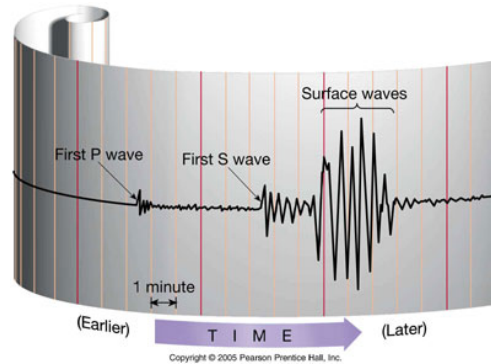

Figure 4.26

Different seismic waves are generated by an earthquake:

Primary waves (or P waves) are the fastest moving waves. They are felt first and cause little damage.

Secondary waves (also called shear waves, or S waves) are another type of body wave. They move a little slower than P waves.

Longitudinal waves (also called long waves, or L waves) move along the surface of the Earth. It is these waves that cause havoc. They move up and down the earth's surface, shaking the foundations of structures like buildings and dam-walls. Surface waves move slower than P and S waves. This means that the most intense shaking usually occurs at the end of the earthquake.

How are people affected by earthquakes?

- People may be killed or injured by collapsing buildings, highways and bridges.
- Buildings may collapse.
- Roads and highways may be damaged and trains may be derailed.
- Power lines are damaged, causing electricity failures.
- Exposed electric wires and broken gas pipes may start fires.
- Dam walls may break, causing floods.
- Landslides may occur.
- Tsunamis may destroy harbours and farms.
- Animals may be killed and their habitats destroyed.
- Damaged infrastructure and a loss of people to work may lead to economic losses.
- The tourism industry could be negatively affected because people may be too scared to travel to areas which are prone to earthquakes and tsunamis.
- Aftershocks can cause further damage.



Figure 4.27 Clearing rubble after an earthquake, Bhuj, India

http://wiki.answers.com/Q/How_does_an_earthquake_have_an_impact_on_people#ixzz1Oag4Qntm



Figure 4.28 Collapsed bridges – USGS

It is possible to classify the impacts of an earthquake, by taking the following factors into account:

- short-term (immediate) impacts
- long-term impacts
- social impacts (the impact on people)
- economic impacts (the impact on the wealth of an area)
- environmental impacts (the impact on the landscape)

	Social impacts	Economic impacts	Environmental impacts
Short-term (immediate) impacts	People may be killed or injured. Homes may be destroyed. Transport and communication links may be disrupted. Water pipes may burst and water supplies may	Shops and business may be destroyed. Looting may take place. The damage to transport and communication links can make trade difficult.	The built landscape may be destroyed. Fires can spread due to gas pipe explosions. Fires can damage areas of woodland. Landslides may occur. Tsunamis may cause flooding

	Social impacts	Economic impacts	Environmental impacts
	be contaminated.		in coastal areas.
Long-term impacts	Disease may spread. People may have to be re-housed, sometimes in refugee camps.	The cost of rebuilding a settlement is high. Investment in the area may be focused only on repairing the damage caused by the earthquake. Income could be lost.	Important natural and human landmarks may be lost.

Why do some earthquakes result in more damage than others?

The following factors may cause more damage:

Physical factors

The magnitude or intensity: Earthquakes with a higher reading on the Richter scale tends to cause more damage to an area.

Distance from the epicentre: Areas closer to the epicentre often experience more damage.

Depth of the focus: When the focus is closer to the earth's surface it travels for a shorter distance, resulting in more intense seismic waves that may create more damage.

If the focus is on the ocean floor a tsunami may follow, resulting in more damage and loss of life.

Soil and underlying rock structure: When water in loose ground material rises during an earthquake, liquefaction occurs. Surface soil becomes soft and very unstable, causing the foundations

Human factors

More economically developed countries are more likely to have highly trained scientist and technology to monitor earth movements can issue warnings more in advance and so save more lives.

Where buildings are not earthquake resistant more people could die because more buildings may collapse and trap or kill people.

In areas where buildings are made of wood more people may die because the wood may catch fire.

Areas of higher population densities often suffer more loss of life because it takes longer to evacuate more people.

Preparedness: If people are educated on what to do during and after an earthquake, more lives are saved. Having regular earthquake drills and well trained rescue teams



of buildings to 'sink' downwards. More damage is then caused.

more people could be saved.

Countries with limited funds and resources may find it more difficult to put emergency plans into action. It may also be difficult for such countries to clear up after the earthquake.

Time of day when an earthquake strikes: When an earthquake occurs during the night when people are asleep, more people could be killed by buildings collapsing on them. Or during rush hour traffic when more vehicles find themselves on highways and other busy roads.

Season: When an earthquake occurs during summer less damage and loss of life could occur because people tend to spend more time outdoors during summer. This could give them a better chance to escape.

What can be done to protect people from earthquakes?

Several measures such as the following can be taken to reduce the impact of earthquakes;

- Earth movements must be studied so that early warnings could be issued.
- Following on early warnings, people must be evacuated in time.
- People must be educated on what to do during and after an earthquake. Earthquake drills must be practised on a regular basis. This must be done at home, school and at work places.
- More earthquake resistant buildings must be built.
- Money must be invested to train rescue teams and medical personnel to respond rapidly in order to save people's lives.

Case studies

Kobe, Japan, 1995 – MEDC

On 17th January 1995, an earthquake struck Kobe, a heavily populated urban area in Japan. It measured 7.4 on the Richter scale and occurred as a result of plate movement along the boundary between the Philippines Plate, Pacific Plate and Eurasian Plate.

Effects

The results of the earthquake are grouped into primary and secondary effects. Primary effects happen immediately, while secondary effects usually occur as a result of the primary effects.

Here are some of the primary and secondary effects which occurred after the Kobe earthquake:

Primary effects

35000 people injured.
Buildings and bridges collapsed despite their earthquake proof design.

Secondary effects

Buildings destroyed by fire when the gas mains fractured.
316000 people left homeless and refugees moved into temporary housing.

These effects can last for a short or long time after the earthquake:

Short term

People were evacuated and emergency rations provided.
Rescue teams searched for survivors for 10 days.

Long term

Many people moved away from the area permanently.
Jobs were created in the construction industry as part of a rebuilding programme.

Kashmir earthquake – LEDC

On 8th October 2005, an earthquake measuring 7.6 on the Richter scale hit the Kashmir region of Pakistan. The earthquake was the result of collision between the Indian and Eurasian plates.

Effects

Primary effects

Buildings collapsed.
79000 people were killed.
Landslides, and large cracks appeared in the ground.

Secondary effects

Broken sewerage pipes contaminated water supplies and spread disease.
People died of cold during the harsh winter.

Short term

The army and emergency services arrived to join the rescue effort.
Tents were given out by charities.
Aid workers arrived from

Long term

Schools and hospitals were rebuilt.
Building regulations were improved to reduce damage and the death rate in future earthquakes.

Short term

abroad to find survivors and treat the injured.

Long term

Very often, the impacts of earthquakes are worse in Less Economically Developed countries than in More Economically Developed countries because LEDCs do not often have the financial resources to implement the measures named above.

Tsunamis

A tsunami is a series of huge waves created when an earthquake occurs on the ocean floor. Tsunamis can also be caused by a volcanic eruption, rockslides under the ocean or by an asteroid or meteoroid crashing into the ocean. Most tsunamis are caused by earthquakes on the ocean floor, but not all sub-marine earthquakes result in tsunamis. The magnitude of an underwater earthquake must be over 6.75 on the Richter scale for it to cause a tsunami. Approximately 90 percent of all tsunamis occur in the Pacific Ocean.

Tsunamis cause damage by two mechanisms: the smashing force of a wall of water travelling at high speed, and the destructive power of a large volume of water draining off the land and carrying all with it, even if the wave did not look large.

How is a tsunami formed?

It happens at destructive plate boundaries where tectonic activity causes a shift in the ocean floor. As one plate drops, the column of water above it drops with the seafloor, while another column of water rises with the sea floor as the plate rises.

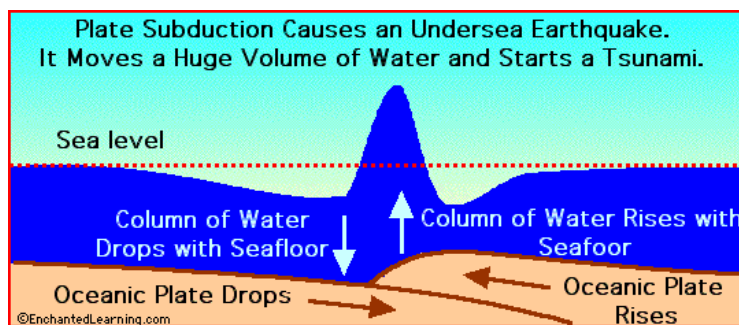

Figure 4.29

Source: EnchantedLearning.com

As the column of water drops, a drawback is created on the beach. This means that water along the shoreline pulls back much further than usual and areas that are normally underwater are exposed. Very often people are amazed at this unusual occurrence and remain on the beach, unaware of the danger that will follow soon.

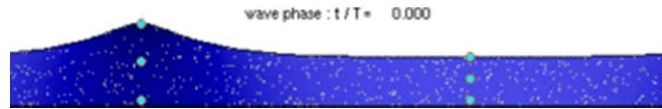

Figure 5.30

Source: Wikipedia - Wave animation showing the initial "drawback" of surface water

As the column of water rises with the seafloor, huge waves are formed. These waves travel in all directions from the starting point, at speeds over 800 kilometres per hour. However, tsunamis are hardly detected further offshore, because of the depth of the water. As the gigantic waves approach the coast, the water becomes shallower. Greater parts of the waves now come into contact with the seafloor, creating more friction, which slows down the bottom part of the wave. The top part of the wave does not experience friction and continue to rush towards the coast at extremely high speeds. The wave increases in height until it eventually topples over, and hits the coast with great force.

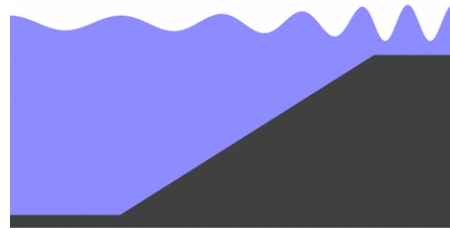

Figure 4.31

When the wave enters shallow water, it slows down and its amplitude (height) increases.

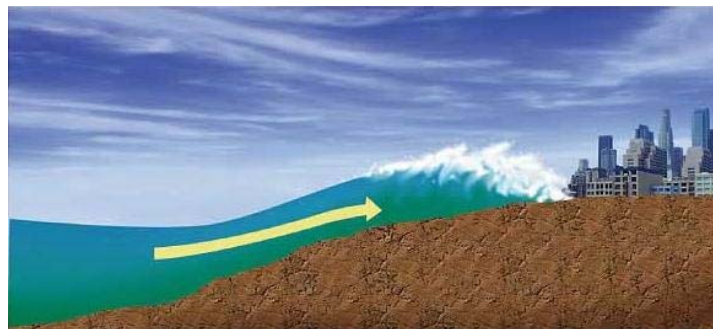

Figure 4.32

The wave further slows and amplifies as it hits land.



What can be done to protect people against tsunamis?

By using modern technology, seismologists are able to detect many tsunamis before they reach the land could be detected before they hit land, and the loss of life could be minimized, with the use of modern technology, including seismographs (which detect earthquakes), computerized offshore buoys that can measure changes in wave height, and a system of sirens on the beach to alert people of potential tsunami danger.



NOTE: If you see the water draw back quickly and unexpectedly from a beach (this is called drawback), run toward higher ground or inland -- there may be a tsunami coming. Also, if you are on the coast and there is an earthquake, it may have caused a tsunami, so run toward higher ground or inland. Some beaches have tsunami warning sirens - do not ignore them. The first wave in a tsunami is often not the largest; if you experience one abnormally - huge wave, go inland quickly - even bigger waves could be coming soon.

Case Study: Japan tsunami – March 2011

Japan weathers its worst crisis since World War II after the magnitude 9.0 earthquake that sent 33-foot tsunami waves crashing into its coast. As more details of the devastation become apparent, the death toll prediction has also been raised to staggering proportions as officials search desperately for survivors.

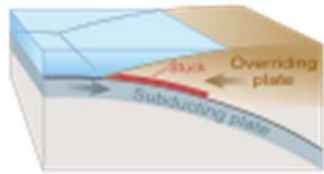
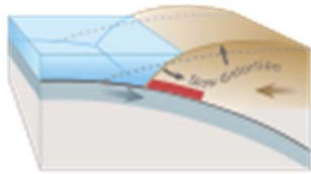
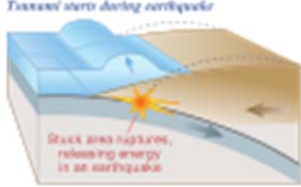
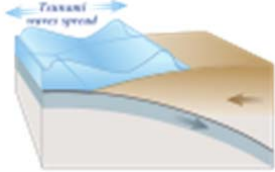
 <ul style="list-style-type: none"> • Figure 4.33 A <p>Drawing of tectonic plate boundary before earthquake</p>	 <ul style="list-style-type: none"> • Figure 4.33 B <p>Overriding plate bulges under strain, causing tectonic uplift.</p>
 <ul style="list-style-type: none"> • Figure 4.33 C <p>Plate slips, causing subsidence and</p>	 <ul style="list-style-type: none"> • Figure 4.33 D <p>The energy released produces</p>

releasing energy into water.

tsunami waves.

Effects of the tsunami:

- People were injured and many others were killed
- The water that travelled inland killed people.

Below are some images showing the devastating effects of tsunamis.



Figure 4.34
A buoy used by the Deep-ocean Assessment and Reporting of Tsunamis (DART) system



Figure 4.35
Smoke from Tagajo City billows into the air after an 8.9 magnitude earthquake struck on March 11, 2011, off the coast of north-eastern Japan. The quake struck offshore at 2:46 p.m. local time, triggering a tsunami wave. (Photo by Kiyoshi Ota/Getty Images)



Figure 4.36
Houses are left damaged by landslides in Fukushima, Japan, after an 8.9 magnitude earthquake struck on March 11, 2011, off the coast of north-eastern Japan. The temblor was



Figure 4.37
A residential area damaged by the tsunami is seen after an 8.9 magnitude earthquake struck on March 11, 2011, off the coast of north-eastern Japan in Sendai. Geologists say the quake was preceded by smaller quakes in the area on March 9. (Photo by Kiyoshi Ota/Getty Images)

one of the strongest in recorded history. (Photo by Kiyoshi Ota/Getty Images)



Figure 4.38

A damaged road is seen after an 8.9 magnitude earthquake struck on March 11, 2011, off the coast of north-eastern Japan in Sendai, Japan. Early damage estimates from the quake and tsunami were in the billions of dollars. (Photo by Kiyoshi Ota/Getty Images)



Figure 4.39

Members of the Ground Self-Defense Forces help local residents as they walk through an area damaged by tsunami after an earthquake on March 11, 2011, off the coast of north-eastern Japan devastated towns such as Sendai. (Photo by Kiyoshi Ota/Getty Images)



Figure 4.40

A damaged gas station in Sendai shows the destruction after a strong earthquake struck the north-eastern coast of Japan on March 11, 2011, followed by tsunami waves that reached 33 feet high. (Photo by Kiyoshi Ota/Getty Images)



Figure 4.41

These two handout satellite photographs provided by the Center for Satellite Based Crisis Information of the German Aerospace Center show the city of Soma and surrounding area before, left, and after the devastating earthquake and tsunami. (Photo by German Aerospace Center DLR/ZKI via Getty Images)

Now do activity 3

Activity



Time Required: In this activity you need at most 45 minutes to fully answer the question.

Activity



How long?

Once done with the activity, please compare your answers with mine before you proceed.



Feedback

Section 4 Volcanoes

A volcano is an opening in the crust through which hot magma, volcanic ash and gases escape from the mantle. The substance that is ejected from a volcano is called **lava**, but is called **magma** while still underground. Let's look at the section outcomes first.

By the end of this section you should be able to:



Section outcomes

- *explain* the relation between plate movements and volcanoes;
- *identify* the global distribution of volcanoes on a world map;
- *identify* what causes volcanoes and draw a simple sketch of a volcano;
- *explain* their impact on people and the environment.

Global distribution of volcanoes

Where do volcanoes occur most frequently? Study the map below to answer the question:

Volcanoes generally occur along destructive and constructive plate boundaries.

For example:

- along the Mid-Atlantic Ocean ridge, which is a constructive plate
- where there is a thinning of the earth's crust in the interior of plates, e.g. in the East African Rift Valley
- along the boundaries of the Pacific plate which makes up the Pacific Ring of Fire (refer to the map below)

The Pacific Ring of Fire refers to the boundaries of the Pacific plate. It is surrounded by the Pacific Ocean. More than 50% of the world's volcanoes occur here. Magma is caused to rise through lines of weaknesses in the crust and erupt, forming these violent chains of volcanoes – referred to as the Pacific Ring of Fire. Frequent earthquakes are also common along the Pacific Ring of Fire. The Pacific Ring of Fire stretches from New Zealand to eastern Asia, to Alaska and along western North and South America.

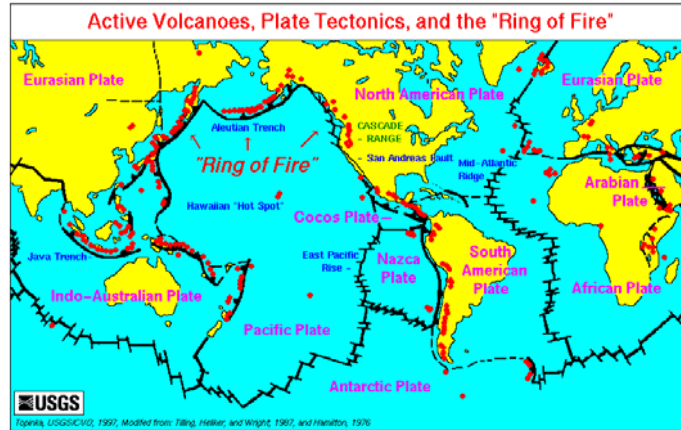

Figure 4.42

Source: <http://library.thinkquest.org/TQ0312395/rof.gif>

The Pacific Ring of Fire



Figure 4.43

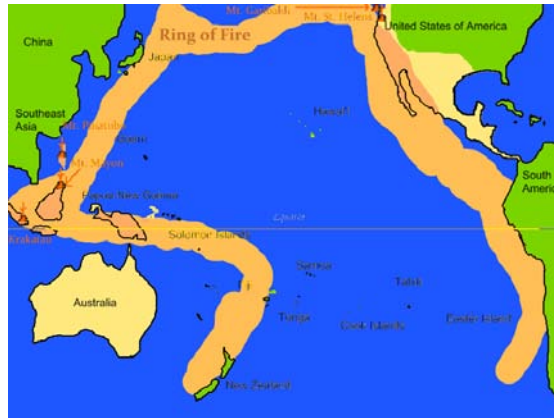
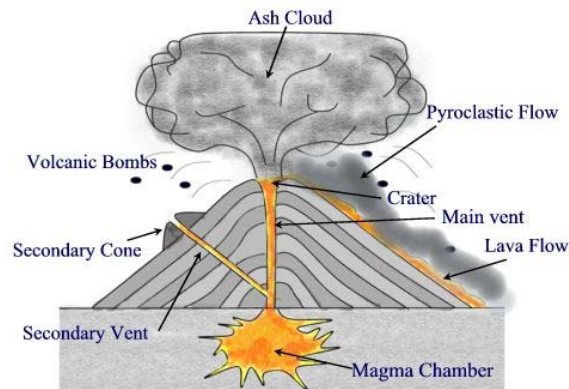

Figure 4.44

What are the main features of a volcano?



Main Features of a Volcano

Figure 4.45

<http://mail.colonial.net/~hkaiter/Aaascienceimages2137/VolcanoStructure.jpg>

The labels of the diagram above are explained in the table below:

Name	Description
magma chamber	The area within the mantle where magma accumulates before rising to the surface
main vent	Conduit / pipe which runs from the magma chamber, along which lava rises.
secondary vent	The pipe running from the main vent, taking magma to the surface.
crater	Opening at the top of the volcano through which lava, gas and volcanic material escape.
secondary crater /	The opening on the side of the volcano where materials



parasitic crater	from the secondary vent are ejected.
secondary cone / parasitic cone	The small volcanic formed on the side of the main volcano created by the materials ejected by the secondary vent.
magma	Molten rock under very high pressure found within the mantle.
lava	molten material that has reached the earth's surface
lava flow	molten material running down the slopes of the volcano
layers of lava and ash	Ash and lava form the layers that shape the volcano over time.
lava layer	Layer of volcanic rock formed by cooled lava.
volcanic bomb	Mass of magma ejected high into the air where it solidifies.
cloud of volcanic ash	Ash is formed of particles less than 0.08 in in diameter; it is composed of pulverized magma and ground rock.

Now let's do activity 4

Activity 4



Activity

Time Required: In this activity you need at most 45 minutes to fully answer the question.



How long?

Add the labels for the following numbers:

- 1 _____
- 3 _____
- 7 _____
- 9 _____
- 11 _____
- 12 _____
- 13 _____
- 14 _____
- 15 _____

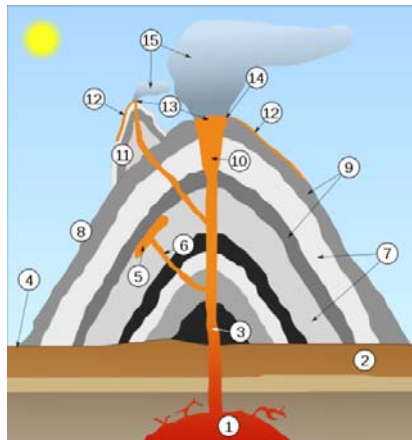

Once done with the activity, please compare your answers with mine before you proceed.



Feedback

Feedback to activity 3

- 1. magma chamber
- 3. Volcanic pipe
- 7. Layers of ash
- 9. Layers of lava
- 11. Parasitic cone
- 12. Lava flow
- 13. Crater / parasitic crater
- 14. Crater
- 15. Ash cloud

How are volcanoes formed?

Use the diagram above with the different processes below to find out how volcanoes erupt.

- 1. Magma rises through cracks or weaknesses in the Earth's crust.
- 2. Pressure builds up inside the Earth.



3. When this pressure is released, e.g. as a result of plate movement, magma explodes to the surface causing a volcanic eruption.
4. The lava from the eruption cools to form new crust.
5. Over time, after several eruptions, the rock builds up and a volcano forms

Compare the features of the volcano in the photograph below with the features of the volcano in the diagram above.



Figure 4.47
Krakatoa in the Sunda Strait, Indonesia

Now do activity 5

Activity 5

Time Required: In this activity you need at most 45 minutes to fully answer the question.



Activity



How long?

Once done with the activity, please compare your answers with mine before you proceed.



Feedback

Classification of volcanoes

Active – volcanoes that erupt regularly.

Dormant - volcanoes that have erupted in historical times but are now quiet. There may still be volcanic activities taking place underground.

Extinct - volcanoes that have not erupted in historical times because all volcanic activity have ceased. Scientists believe that they will not erupt again because they no longer have a lava supply.

Different types of volcanoes

Shield volcanoes

These volcanoes have broad and gentle slopes. They are called shield volcanoes because they remind of the shields of soldiers in earlier centuries. They occur along constructive plate boundaries and lava flows gently onto the surface. Lava is very hot, about 1200°C, thin (low viscosity) and has low silica content. It flows for long distances before cooling and solidifying. These volcanoes are common in Hawaii and Iceland.



Figure 4.48
A shield volcano in Iceland

Volcanic cones or cinder cones

Cinder cone volcanoes produce cinders which are small pyroclastic pieces, which build up around the vent. They produce cone-shaped hills.



Figure 4.49
A cinder cone volcano near Veyo, Utah

Strato volcanoes or composite volcanoes

These volcanoes are tall conical mountains composed of lava flows and other material in alternate layers. It is these layers or strata that give rise to the name. Strato volcanoes are also known as composite volcanoes, and are made of cinders, ash and lava. Cinders and ash pile on top of each other, lava flows on top of the ash, where it cools and hardens, and then the process begins again. Their slopes are steep because the lava is thick and sticky (very viscous) and has a high silica content. Lava is about 800°C and cools and solidifies quickly.

Strato volcanoes are seen as the most dangerous because ash is produced by an explosive eruption. They eject pyroclastic material, tephra and can produce lahars.

Pyroclastic flows are mixtures of hot ash, rock fragments, and gas. They are deadly because of their high temperatures of 850°C or higher and can reach speeds of 250 km/h or greater.



Figure 4.50
A strato volcano in the Philippines

Effects of volcanoes

Problems created by volcanoes:

- Materials ejected by volcanoes can kill or injure people and animals.
- The weight of volcanic ash may cause roofs to collapse.
- Running lava destroys crops and forests.
- When ash falls on crops, these are damaged – it could lead to food problems.
- Sulphur dioxide emissions from volcanoes contribute to acid rain.
- Dust and ash clouds creates atmospheric pollution.
- Volcanic ash may interfere with the mechanics of the engines of aircraft because ash particles are melted by the high operating temperatures. As a result air travel is disrupted.
- Volcanic eruptions may also eject aerosols into the atmosphere.
- Large injections may cause visual effects such as unusually colorful sunsets and affect global climate mainly by cooling it. Volcanic eruptions also provide the benefit of adding nutrients to soil through the weathering process of volcanic rocks. These fertile soils assist the growth of plants and various crops. Volcanic eruptions can also create new islands, as the magma cools and solidifies upon contact with the water.

Volcano Benefits:

- Volcanic ash produces fertile soil.
- New land is created as the magma cools and solidifies.
- Geothermal electricity can be generated from the natural heat of created by volcanic activity.
- Diamonds and other minerals (copper, lead, zinc, gold, silver) are often found within volcanic rocks.
- Geysers, hot springs and hot springs are great tourist attractions and can also be used to harness geothermal electricity.
- Ash clouds may result in spectacular sunsets.
- Tourism is stimulated as tourists may want to see volcanoes.
- Crushed lava rocks, pumice, cinders, and other eruptive products are a source of raw materials for the road-building, constructing, manufacturing and landscaping industries.

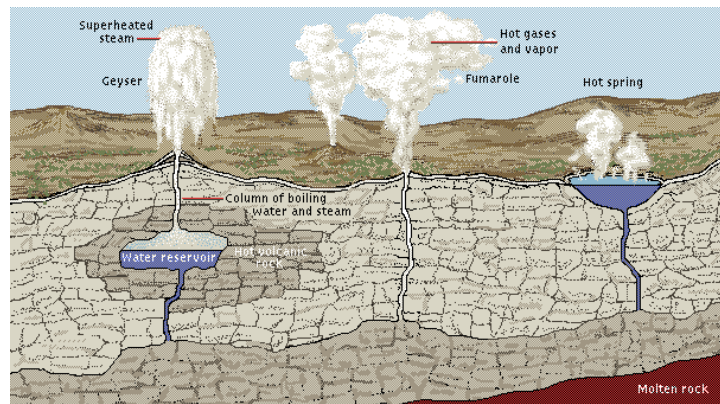

Figure 4.51

<http://www.angelfire.com/rings/mibu/images/T046050A.gif>

Geyser

Hot water spring that squirts out water and superheated steam with great force.

Fumaroles

Regular emission of gas from a fissure on the Earth's surface.

Hot spring

Underground water, heated by volcanic rocks, which come up naturally on the earth's surface.

Case Study: Mount Pinatubo

Benefits of Volcano Monitoring Far Outweigh Costs—The Case of Mount Pinatubo

The climactic June 1991 eruption of Mount Pinatubo, Philippines, was the largest volcanic eruption in this century to affect a heavily populated area. Because it was forecast by scientists from the Philippine Institute of Volcanology and Seismology and the U.S. Geological Survey, civil and military leaders were able to order massive evacuations and take measures to protect property before the eruption. Thousands of lives were saved and hundreds of millions of dollars in property losses averted. The savings in property alone were many times the total costs of the forecasting and evacuations.

On the morning of June 15, 1991, Mount Pinatubo on the island of Luzon in the Philippines exploded in the largest volcanic eruption on Earth in more than three-quarters of a century. The most powerful phase of this cataclysmic eruption lasted more than 10 hours, creating an enormous

cloud of volcanic ash that rose as high as 35 kilometres into the air and grew to more than 482 kilometres across, turning day into night over central Luzon. Falling ash blanketed an area of thousands of square miles, and avalanches of hot ash (pyroclastic flows) roared down the slopes of the volcano and filled deep valleys with deposits of ash as much as 182 metres thick.



Figure 4.52

Villagers fleeing the vicinity of Mount Pinatubo, Philip-pines, during heavy ash fall from the volcano's cataclysmic June 15, 1991, eruption. Scientists from the Philip-pine Institute of Volcanology and Seismology and the U.S. Geological Survey forecast this eruption, enabling people living near the volcano to evacuate to safety. The timely forecasts of these scientists saved at least 5,000 lives and prevented property losses of at least \$250 million. (Photo by Philippe Bourseiller/Jacques Durieux.)

Before the cataclysmic eruption, about 1,000,000 people lived in the region around Mount Pinatubo, including about 20,000 American military personnel and their dependents at the two largest U.S. military bases in the Philippines—Clark Air Base and Subic Bay Naval Station. The slopes of the volcano and the adjacent hills and valleys were home to thousands of villagers. Despite the great number of people at risk, there were few casualties in the June 15 eruption. This was not due to good luck but rather was the result of intensive monitoring of Mount Pinatubo by scientists with the Philippine Institute of Volcanology and Seismology (PHIVOLCS) and the U.S. Geological Survey (USGS).

The first recognized signs that Pinatubo was reawakening after a 500-year slumber were a series of small steam-blast explosions in early April 1991. Scientists from PHIVOLCS immediately began on-site monitoring and soon declared a 10-kilometer radius danger zone around the volcano. They were joined in a few weeks by USGS scientists from the Volcano Disaster Assistance Program, a cooperative effort with the Office of Foreign Disaster Assistance of the U.S. Agency for International Development.



Figure 4.53

Scientists from the U.S. Geological Survey and the Philippine Institute of Volcanology and Seismology making emergency repairs to monitoring instruments on Mount Pinatubo, Philippines, with U.S. Air Force helicopter support, the day before the volcano's cataclysmic June 15, 1991, eruption. (Photo by MSgt. Val Gempis, U.S. Air Force.)

The USGS scientists brought with them specially designed, portable instruments, which the joint Philippine-American team used to quickly set up monitoring networks on and around Mount Pinatubo. The team also conducted intensive studies of the volcano's past eruptive history. When the data from these efforts indicated that a huge eruption of the volcano was imminent, the joint team issued urgent warnings. These timely forecasts enabled civil and military authorities to arrange the evacuation of people and aircraft and other equipment to safe areas before Mount Pinatubo exploded on June 15.

Lives and Property Saved

The USGS and PHIVOLCS estimate that their forecasts saved at least 5,000 lives and perhaps as many as 20,000. The people living in the lowlands around Mount Pinatubo were alerted to the impending eruption by the forecasts, and many fled to towns at safer distances from the volcano or took shelter in buildings with strong roofs. Additionally, more than 15,000 American servicemen and their dependents were evacuated from Clark Air Base prior to the June 15 eruption. In the eruption, thousands of weaker roofs, including some on Clark, collapsed under the weight of ash made wet by heavy rains, yet only about 250 lowland residents were killed. Of the 20,000 indigenous Aeta highlanders who lived on the slopes of Mount Pinatubo, all but about 20 were safely evacuated before the eruption completely devastated their villages. Some might have left on their own—troubled by the steam blasts and earthquakes that preceded the eruption—but most would have remained had it not been for the forecasts and government-led evacuations.

In addition to the many lives saved, property worth hundreds of millions of dollars was protected from damage or destruction in the eruption. When aircraft and other equipment at the U.S. bases were flown to safe areas or covered, losses of at least \$200 to 275 million were averted. Philippine and other commercial airlines prevented at least another \$50 to 100 million in damage to aircraft by taking similar actions. By heeding warnings of hazardous volcanic ash clouds from Pinatubo, commercial and military pilots avoided severe damage to their aircraft and potentially saved hundreds of lives. Other commercial savings are harder to quantify but were probably less than \$100 million, and there is no way to estimate the sentimental or monetary value of the personal property saved by families.

Cost of Forecasting and Evacuations

PHIVOLCS and USGS scientists spent less than \$1.5 million responding to Mount Pinatubo's reawakening and forecasting its June 15, 1991, eruption, including salaries, helicopter and other logistical support, and the replacement of equipment destroyed by the eruption. Their forecasts were made possible by previous work in the area by PHIVOLCS and by the USGS' mobile monitoring capability, also available to respond to volcano crises in the United States. The costs of these earlier efforts can be roughly estimated at \$15 million (10 percent of the combined 1980&endash;90 volcano hazards budgets of PHIVOLCS and the USGS). Additionally, the Philippine and U.S. Governments and nongovernmental organizations together spent about \$40 million to evacuate, house, and feed local residents and American military personnel and their dependents.

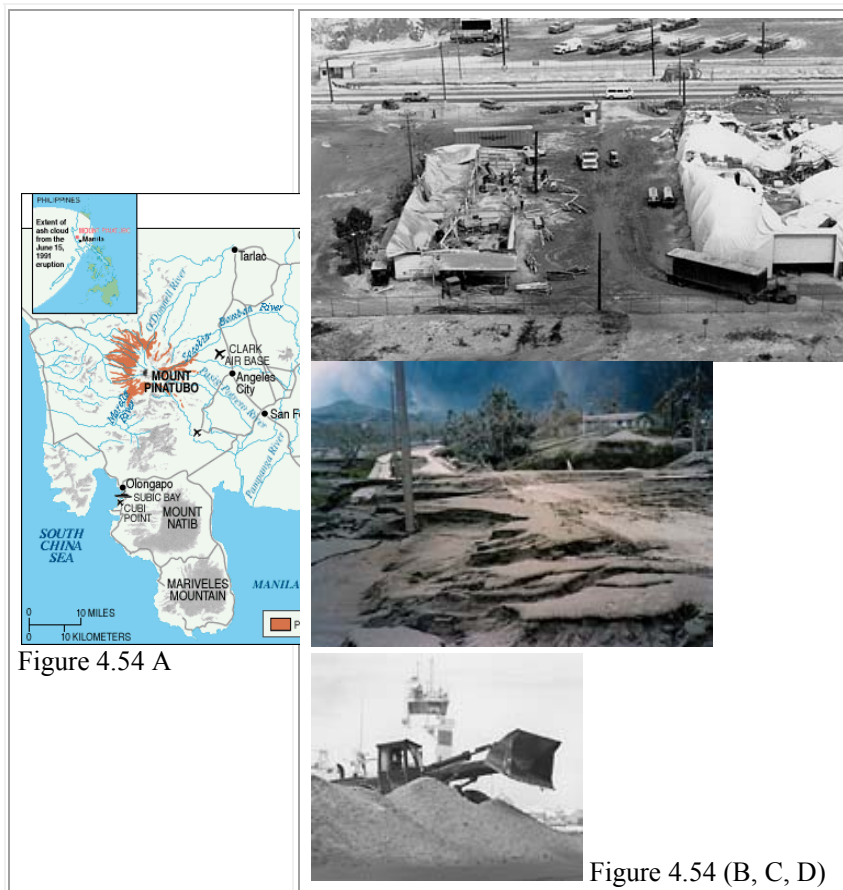

On June 15, 1991, Mount Pinatubo in the Philippines erupted cataclysmically, raining volcanic ash over an area of thousands of square miles and sending high-speed avalanches of hot ash (pyroclastic flows) roaring down the flanks of the volcano. Falling ash caused thousands of roofs to collapse, clogged stream channels, made roads impassable, and created massive cleanup problems (photos). Before the eruption more than 1,000,000 people lived within 48 kilometres of the volcano, including about 20,000 American military personnel and their



dependents. Because forecasts of this powerful eruption by a joint team of U.S. Geological Survey and Philippine scientists allowed timely evacuations, fewer than 300 people were killed. (U.S. bases have reverted to Philippine control since 1991.)

Were These Efforts a Good Investment?

The monitoring of Mount Pinatubo in 1991 and the successful forecasting of its cataclysmic June 15 eruption prevented property losses of at least \$250 million (this figure is intentionally conservative and should be considered a minimum value). No monetary value has been placed on the more than 5,000 lives saved, although other cost-benefit analyses have used values from \$100,000 to \$1 million per life.

Even when the costs of developing the portable monitoring capability and of the earlier studies of Mount Pinatubo are included, the total costs of safeguarding lives and property from the volcano's June 15, 1991, eruption were only about \$56 million. The savings in property alone amounted to at least five times this total investment!

Although savings may not always be as dramatic as those realized at Pinatubo, many lives can be saved and major property losses avoided in other volcano crises through similar relatively modest investments in volcano monitoring and eruption forecasting. The experience gained by scientists during Pinatubo's 1991 eruption crisis is being used by the USGS Volcano Hazards Program in the United States and by PHIVOLCS in the Philippines to better protect people's lives and property from the future volcanic eruptions that will inevitably occur. This is the end of section 4. In section 5 we will look at exogenic forces.

Section 5 Exogenic (external) forces

Exogenic simply means external forces. In this section we will explain how external forces have an influence of rocks specifically. As in the previous sections I want you to look at the section outcomes first.

By the end of this section you should be able to:

- *differentiate* between weathering and erosion;
- *distinguish* between mechanical, chemical and biological weathering;
- *recognise* the agents of erosion, such as running water, wind and moving ice;
- *identify* the landforms created by weathering and erosion.



Section outcomes

What is the difference between weathering and erosion?

Weathering: The breaking down of rocks into smaller particles in situ. This means that rocks lying on the surface are broken into smaller pieces with no movement involved.

Erosion: The removal of weathered material from one place to another due to the action of wind, water or ice.

Different types of weathering:

1. Freeze-thaw weathering:

This type of weathering occurs in mountainous areas, where temperatures fluctuate above and below freezing point. Snow on high mountain tops melt during the day when temperatures rise. The melt water runs into cracks of rocks. At night the water freezes when temperatures drop below freezing point. The following day ice melts again and water runs deeper into the cracks. The process is repeated until cracks become wider and parts of the rock eventually break off. The parts that break off fall down the mountain and collect at the foot of the mountain and are called scree.

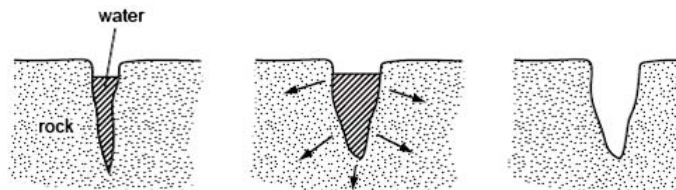

Figure 4.55

Source: Cambridge International Examinations



Figure 4.56

Source: Cambridge International Examinations

2. Exfoliation:

This type of weathering occurs in hot deserts with temperature extremes. During the day temperatures rise. Rocks heat and expand. At night temperatures drop so rocks cool down and contract. Continuous expansion and contractions weakens the rock. Outer layers expand and contract faster and peel off layer by layer.



Figure 4.57
http://i1.treklens.com/photos/26649/finder_of_god.jpg



Figure 4.58
<http://upload.wikimedia.org/wikipedia/commons/b/b8/45172890.lud569.jpg>



Figure 4.59
http://www.klausdierks.com/images/Namibia.FishRiver_Canyon3.jpg

Bogenfels is a location in the coastal Namib Desert of Namibia, noted for its natural rock formations (hence the name, which means "arch rock"). The main formation is a 55 metre high rock arch close to the coast. It is not easily accessible, due to the terrain and its location within a restricted diamond-mining area, but there are official guided tours.



Figure 4.60
http://upload.wikimedia.org/wikipedia/commons/thumb/5/51/D%C3%BCne_S-Schlag_Sossusvlei.JPG/800px-D%C3%BCne_S-Schlag_Sossusvlei.JPG

Erosion

Cliff erosion in Pacifica, California



Figure 4.61 From Wikipedia, the free encyclopedia

Erosion is the process of weathering and transport of solids (sediment, soil, rock and other particles) in the natural environment or their source and deposits them elsewhere. It usually occurs due to transport by wind, water, or ice; by down-slope creep of soil and other material under the force of gravity; or by living organisms, such as burrowing animals, in the case of bioerosion.

Erosion is a natural process, but it has been increased dramatically by human land use and we have a negative effect on erosion, especially industrial agriculture, deforestation, and urban sprawl. Land that is used for industrial agriculture generally experiences a significantly greater rate of erosion than that of land under natural vegetation, or land used for sustainable agricultural practices. This is particularly true if tillage is used, which reduces vegetation cover on the surface of the soil and disturbs both soil structure and plant roots that would otherwise hold the soil in place. However, improved land use practices can limit erosion, using techniques such as terrace-building, no-till, and tree planting.

A certain amount of erosion is natural and, in fact, healthy for the ecosystem. For example, gravels continuously move downstream in watercourses. Excessive erosion, however, causes serious problems, such as receiving water sedimentation, ecosystem damage and outright loss of soil.

Erosion is distinguished from weathering, which is the process of chemical or physical breakdown of the minerals in the rocks, although the two processes may occur concurrently.

Causes



Figure 4.62
Soil erosion exposing roots



Figure 4.63
A natural arch produced by erosion of differentially weathered rock in Jebel Kharaz (Jordan)

The rate of erosion depends on many factors. Climatic factors include the amount and intensity of precipitation, the average temperature, as well as the typical temperature range, and seasonality, the wind speed, storm frequency. Erosion is caused by “fluid flow”. Any substance, like wind, water, or ice, which flows consistently from one place to another, will facilitate erosion. The geologic factors include the sediment or rock type, its porosity and permeability, the slope (gradient) of the land, and whether the rocks are tilted, faulted, folded, or weathered. The biological factors include ground cover from vegetation or lack thereof, the type of organisms inhabiting the area, and the land use.

In general, given similar vegetation and ecosystems, areas with high-intensity precipitation, more frequent rainfall, more wind, or more storms are expected to have more erosion. Sediment with high sand or silt contents and areas with steep slopes erode more easily, as do areas with highly fractured or weathered rock. Porosity and permeability of the sediment or rock affect the speed with which the water can percolate into the ground. If the water moves underground, less runoff is generated, reducing the amount of surface erosion. Sediments containing more clay tend to erode less than those with sand or silt. Here, however, the impact of atmospheric sodium on erodibility of clay should be considered.

The factor that is most subject to change is the amount and type of ground cover. In an undisturbed forest, the mineral soil is protected by a litter layer and an organic layer. These two layers protect the soil by absorbing the impact of rain drops. These layers and the underlying soil in a forest are porous and highly permeable to rainfall. Typically, only the most severe rainfall and large hailstorm events will lead to overland flow in a forest. If the trees are removed by fire or logging, infiltration rates become high and erosion low to the degree the forest floor remains intact. Severe fires can lead to significantly increased erosion if followed by heavy rainfall. In the case of construction or road building, when the litter layer is removed or compacted, the susceptibility of the soil to erosion is greatly increased.

Roads are especially likely to cause increased rates of erosion because, in addition to removing ground cover, they can significantly change

drainage patterns, especially if an embankment has been made to support the road. A road that has a lot of rock and one that is "hydrologically invisible" (that gets the water off the road as quickly as possible, mimicking natural drainage patterns) has the best chance of not causing increased erosion.

Many human activities remove vegetation from an area, making the soil susceptible to erosion. Logging can cause increased erosion rates due to soil compaction, exposure of mineral soil, for example roads and landings. However it is the removal of or compromise to the forest floor not the removal of the canopy that can lead to erosion. This is because rain drops striking tree leaves coalesce with other rain drops creating larger drops. When these larger drops fall (called throughfall) they again may reach terminal velocity and strike the ground with more energy than had they fallen in the open. Terminal velocity of rain drops is reached in about 8 meters. Because forest canopies are usually higher than this, leaf drop can regain terminal velocity. However, the intact forest floor, with its layers of leaf litter and organic matter, absorbs the impact of the rainfall.



Figure 4.64

A Linxia City, China, farmer is gradually losing his land as the edge of the loess plateau is eroded away

Heavy grazing can reduce vegetation enough to increase erosion. Changes in the kind of vegetation in an area can also affect erosion rates. Different kinds of vegetation lead to different infiltration rates of rain into the soil. Forested areas have higher infiltration rates, so precipitation will result in less surface runoff, which erodes. Instead much of the water will go in subsurface flows, which are generally less erosive. Leaf litter and low shrubs are an important part of the high infiltration rates of forested systems, the removal of which can increase erosion rates. Leaf litter also shelters the soil from the impact of falling raindrops, which is a significant agent of erosion. Vegetation can also change the speed of surface runoff flows, so grasses and shrubs can also be instrumental in this aspect.

One of the main causes of erosive soil loss in the year 2006 is the result of slash and burn treatment of tropical forest. When the total ground surface is stripped of vegetation and then seared of all living organisms, the upper soils are vulnerable to both wind and water erosion. In a number of regions of the earth, entire sectors of a country have been rendered unproductive. For example, on the Madagascar high central plateau, comprising approximately ten percent of that country's land area,



virtually the entire landscape is sterile of vegetation, with gully erosive furrows typically in excess of 50 meters deep and one kilometer wide. Shifting cultivation is a farming system which sometimes incorporates the slash and burn method in some regions of the world. This degrades the soil and causes the soil to become less and less fertile.

Effects

Approximately 40% of the world's agricultural land is seriously degraded. According to the UN, an area of fertile soil the size of Ukraine is lost every year because of drought, deforestation and climate change. In Africa, if current trends of soil degradation continue, the continent might be able to feed just 25% of its population by 2025, according to UNU's Ghana-based Institute for Natural Resources in Africa.



Figure 4.65
Bank erosion started by four wheeler all-terrain vehicles, Yauhanna, South Carolina

When land is overused by animal activities (including humans), there can be mechanical erosion and also removal of vegetation leading to erosion. In the case of the animal kingdom, this effect would become material primarily with very large animal herds stampeding such as the Blue Wildebeest on the Serengeti plain. Even in this case there are broader material benefits to the ecosystem, such as continuing the survival of grasslands, that are indigenous to this region. This effect may be viewed as anomalous or a problem only when there is a significant imbalance or overpopulation of one species.

In the case of human use, the effects are also generally linked to overpopulation. When large number of hikers use trails or extensive off road vehicle use occurs, erosive effects often follow, arising from vegetation removal and furrowing of foot traffic and off road vehicle tires. These effects can also accumulate from a variety of outdoor human activities, again simply arising from too many people using a finite land resource.

One of the most serious and long-running water erosion problems worldwide is in the People's Republic of China, on the middle reaches of the Yellow River and the upper reaches of the Yangtze River. From the Yellow River, over 1.6 billion tons of sediment flows into the ocean each

year. The sediment originates primarily from water erosion in the Loess Plateau region of the northwest.

Processes

Gravity



Figure 4.66

Wadi in Makhtesh Ramon, Israel, showing gravity collapse erosion on its banks.

Mass wasting is the down-slope movement of rock and sediments, mainly due to the force of gravity. Mass movement is an important part of the erosional process, as it moves material from higher elevations to lower elevations where other eroding agents such as streams and glaciers can then pick up the material and move it to even lower elevations. Mass-movement processes are always occurring continuously on all slopes; some mass-movement processes act very slowly; others occur very suddenly, often with disastrous results. Any perceptible down-slope movement of rock or sediment is often referred to in general terms as a landslide. However, landslides can be classified in a much more detailed way that reflects the mechanisms responsible for the movement and the velocity at which the movement occurs. One of the visible topographical manifestations of a very slow form of such activity is a scree slope.

Slumping happens on steep hillsides, occurring along distinct fracture zones, often within materials like clay that, once released, may move quite rapidly downhill. They will often show a spoon-shaped isostatic depression, in which the material has begun to slide downhill. In some cases, the slump is caused by water beneath the slope weakening it. In many cases it is simply the result of poor engineering along highways where it is a regular occurrence.

Surface creep is the slow movement of soil and rock debris by gravity which is usually not perceptible except through extended observation. However, the term can also describe the rolling of dislodged soil particles 0.5 to 1.0 mm in diameter by wind along the soil surface.

Water



Figure 4.67
Nearly perfect sphere in granite, Trégastel, Brittany.

Splash erosion is the detachment and airborne movement of small soil particles caused by the impact of raindrops on soil.

Sheet erosion is the detachment of soil particles by raindrop impact and their removal downslope by water flowing overland as a sheet instead of in definite channels or rills. The impact of the raindrop breaks apart the soil aggregate. Particles of clay, silt and sand fill the soil pores and reduce infiltration. After the surface pores are filled with sand, silt or clay, overland surface flow of water begins due to the lowering of infiltration rates. Once the rate of falling rain is faster than infiltration, runoff takes place. There are two stages of sheet erosion. The first is rain splash, in which soil particles are knocked into the air by raindrop impact. In the second stage, the loose particles are moved downslope by broad sheets of rapidly flowing water filled with sediment known as sheetfloods. This stage of sheet erosion is generally produced by cloudbursts, sheetfloods commonly travel short distances and last only for a short time.

Rill erosion refers to the development of small, ephemeral concentrated flow paths, which function as both sediment source and sediment delivery systems for erosion on hillslopes. Generally, where water erosion rates on disturbed upland areas are greatest, rills are active. Flow depths in rills are typically on the order of a few centimeters or less and slopes may be quite steep. These conditions constitute a very different hydraulic environment than typically found in channels of streams and rivers. Eroding rills evolve morphologically in time and space. The rill bed surface changes as soil erodes, which in turn alters the hydraulics of the flow. The hydraulics is the driving mechanism for the erosion process, and therefore dynamically changing hydraulic patterns cause continually changing erosional patterns in the rill. Thus, the process of rill evolution involves a feedback loop between flow detachment, hydraulics, and bed form. Flow velocity, depth, width, hydraulic roughness, local bed slope, friction slope, and detachment rate are time and space variable functions of the rill evolutionary process. Superimposed on these interactive processes, the sediment load, or amount of sediment in the flow, has a large influence on soil detachment rates in rills. As sediment load increases, the ability of the flowing water to detach more sediment decreases.

Where precipitation rates exceed soil infiltration rates, *runoff* occurs. Surface runoff turbulence can often cause more erosion than the initial raindrop impact.

Gully erosion, also called *ephemeral gully erosion*, occurs when water flows in narrow channels during or immediately after heavy rains or melting snow. This is particularly noticeable in the formation of hollow ways, where, prior to being tarmacked, an old rural road has over many years become significantly lower than the surrounding fields.

A gully is sufficiently deep that it would not be routinely destroyed by tillage operations, whereas rill erosion is smoothed by ordinary farm tillage. The narrow channels, or gullies, may be of considerable depth, ranging from 0.61 m to as much as 30 m. Gully erosion is not accounted for in the revised universal soil loss equation.

Valley or stream erosion occurs with continued water flow along a linear feature. The erosion is both downward, deepening the valley, and headward, extending the valley into the hillside. In the earliest stage of stream erosion, the erosive activity is dominantly vertical, the valleys have a typical **V** cross-section and the stream gradient is relatively steep. When some base level is reached, the erosive activity switches to lateral erosion, which widens the valley floor and creates a narrow floodplain. The stream gradient becomes nearly flat, and lateral deposition of sediments becomes important as the stream meanders across the valley floor. In all stages of stream erosion, by far the most erosion occurs during times of flood, when more and faster-moving water is available to carry a larger sediment load. In such processes, it is not the water alone that erodes: suspended abrasive particles, pebbles and boulders can also act erosively as they traverse a surface.

At extremely high flows, kolks, or vortices are formed by large volumes of rapidly rushing water. Kolks cause extreme local erosion, plucking bedrock and creating pothole-type geographical features called Rock-cut basins. Examples can be seen in the flood regions result from glacial Lake Missoula, which created the channeled scablands in the Columbia Basin region of eastern Washington.

Bank erosion is the wearing away of the banks of a stream or river. This is distinguished from changes on the bed of the watercourse, which is referred to as *scour*. Erosion and changes in the form of river banks may be measured by inserting metal rods into the bank and marking the position of the bank surface along the rods at different times.

Shoreline



Figure 4.68
Erosion due to wave
pounding at Venus Bay,
South Australia.



Figure 4.69
Wave cut platform caused by erosion of
cliffs by the sea, at Southerndown in
South Wales

Shoreline erosion, which occurs on both exposed and sheltered coasts, primarily occurs through the action of currents and waves but sea level (tidal) change can also play a role.

Hydraulic action takes place when air in a joint is suddenly compressed by a wave closing the entrance of the joint. This then cracks it. *Wave pounding* is when the sheer energy of the wave hitting the cliff or rock breaks pieces off. *Abrasion* or *corrasion* is caused by waves launching seaload at the cliff. It is the most effective and rapid form of shoreline erosion (not to be confused with *corrosion*). *Corrosion* is the dissolving of rock by carbonic acid in sea water. Limestone cliffs are particularly vulnerable to this kind of erosion. *Attrition* is where particles/seaload carried by the waves are worn down as they hit each other and the cliffs. This then makes the material easier to wash away. The material ends up as shingle and sand. Another significant source of erosion, particularly on carbonate coastlines, is the boring, scraping and grinding of organisms, a process termed *bioerosion*.

Sediment is transported along the coast in the direction of the prevailing current (longshore drift). When the upcurrent amount of sediment is less than the amount being carried away, erosion occurs. When the upcurrent amount of sediment is greater, sand or gravel banks will tend to form. These banks may slowly migrate along the coast in the direction of the longshore drift, alternately protecting and exposing parts of the coastline. Where there is a bend in the coastline, quite often a build up of eroded material occurs forming a long narrow bank (a spit). Armoured beaches and submerged offshore sandbanks may also protect parts of a coastline from erosion. Over the years, as the shoals gradually shift, the erosion may be redirected to attack different parts of the shore.

For example, the large-scale oceanic erosion that has been taking place off the coast of southwest Japan can illustrate the environmental effects of erosion. Over time, a V-shaped depression has formed in the ocean

floor which, in turn, has released methane gas into the water and atmosphere. Once this gas was released, it further facilitated erosion through gas erosion by creating a positive feedback loop. As more and more methane was released, more sedimentary rock was eroded, thus worsening the problem.

Ice

Ice erosion can take one of two forms. It can be caused by the movement of ice, typically as glaciers, in a process called *glacial erosion*. It can also be due to freeze-thaw processes in which water inside pores and fractures in rock may expand causing further cracking.

Glaciers erode predominantly by three different processes: abrasion/scouring, plucking, and ice thrusting. In an abrasion process, debris in the basal ice scrapes along the bed, polishing and gouging the underlying rocks, similar to sandpaper on wood. Glaciers can also cause pieces of bedrock to crack off in the process of plucking. In ice thrusting, the glacier freezes to its bed, then as it surges forward, it moves large sheets of frozen sediment at the base along with the glacier. This method produced some of the many thousands of lake basins that dot the edge of the Canadian Shield. These processes, combined with erosion and transport by the water network beneath the glacier, leave moraines, drumlins, ground moraine (till), kames, kame deltas, moulins, and glacial erratics in their wake, typically at the terminus or during glacier retreat.

Cold weather causes water trapped in tiny rock cracks to freeze and expand, breaking the rock into several pieces. This can lead to gravity erosion on steep slopes. The scree which forms at the bottom of a steep mountainside is mostly formed from pieces of rock (soil) broken away by this means. It is a common engineering problem wherever rock cliffs are alongside roads, because morning thaws can drop hazardous rock pieces onto the road.

In some places, water seeps into rocks during the daytime, then freezes at night. Ice expands, thus, creating a wedge in the rock. Over time, the repetition in the forming and melting of the ice causes fissures, which eventually breaks the rock down.

Wind



Figure 4.70
A rock formation in the Altiplano, Bolivia sculpted by wind erosion.



Figure 4.71
Wind-eroded alcove near Moab, Utah.

In arid climates, the main source of erosion is wind. The general wind circulation moves small particulates such as dust across wide oceans



thousands of kilometers downwind of their point of origin, which is known as deflation. Erosion can be the result of material movement by the wind. There are two main effects. First, wind causes small particles to be lifted and therefore moved to another region. This is called deflation. Second, these suspended particles may impact on solid objects causing erosion by abrasion (ecological succession). Wind erosion generally occurs in areas with little or no vegetation, often in areas where there is insufficient rainfall to support vegetation. An example is the formation of sand dunes, on a beach or in a desert. Loess is a homogeneous, typically nonstratified, porous, friable, slightly coherent, often calcareous, fine-grained, silty, pale yellow or buff, windblown (aeolian) sediment. It generally occurs as a widespread blanket deposit that covers areas of hundreds of square kilometers and tens of meters thick. Loess often stands in either steep or vertical faces. Loess tends to develop into highly rich soils. Under appropriate climatic conditions, areas with loess are among the most agriculturally productive in the world. Loess deposits are geologically unstable by nature, and will erode very readily. Therefore, windbreaks (such as big trees and bushes) are often planted by farmers to reduce the wind erosion of loess.

Thermal

Thermal erosion is the result of melting and weakening permafrost due to moving water. It can occur both along rivers and at the coast. Rapid river channel migration observed in the Lena River of Siberia is due to thermal erosion, as these portions of the banks are composed of permafrost-cemented non-cohesive materials. Much of this erosion occurs as the weakened banks fail in large slumps. Thermal erosion also affects the Arctic coast, where wave action and near-shore temperatures combine to undercut permafrost bluffs along the shoreline and cause them to fail. Annual erosion rates along a 100-kilometer segment of the Beaufort Sea shoreline averaged 5.6 meters per year from 1955 to 2002.

Soil erosion and climate change

The warmer atmospheric temperatures observed over the past decades are expected to lead to a more vigorous hydrological cycle, including more extreme rainfall events. In 1998 Karl and Knight reported that from 1910 to 1996 total precipitation over the contiguous U.S. increased, and that 53% of the increase came from the upper 10% of precipitation events (the most intense precipitation). The percent of precipitation coming from days of precipitation in excess of 50 mm has also increased significantly.

Studies on soil erosion suggest that increased rainfall amounts and intensities will lead to greater rates of erosion. Thus, if rainfall amounts and intensities increase in many parts of the world as expected, erosion will also increase, unless amelioration measures are taken. Soil erosion rates are expected to change in response to changes in climate for a variety of reasons. The most direct is the change in the erosive power of rainfall. Other reasons include:

- a) changes in plant canopy caused by shifts in plant biomass production associated with moisture regime;
- b) changes in litter cover on the ground caused by changes in both plant residue decomposition rates driven by temperature and moisture

dependent soil microbial activity as well as plant biomass production rates;

c) changes in soil moisture due to shifting precipitation regimes and evapo-transpiration rates, which changes infiltration and runoff ratios;

d) soil erodibility changes due to decrease in soil organic matter concentrations in soils that lead to a soil structure that is more susceptible to erosion and increased runoff due to increased soil surface sealing and crusting;

e) a shift of winter precipitation from non-erosive snow to erosive rainfall due to increasing winter temperatures;

f) melting of permafrost, which induces an erodible soil state from a previously non-erodible one; and

g) shifts in land use made necessary to accommodate new climatic regimes.

Studies by Pruski and Nearing indicated that, other factors such as land use not considered, we can expect approximately a 1.7% change in soil erosion for each 1% change in total precipitation under climate change.

Measuring & Preventing Erosion

Erosion is measured and further understood using tools such as the micro-erosion meter (MEM) and the traversing micro-erosion meter (TMEM). The MEM has proved helpful in measuring bedrock erosion in various ecosystems around the world. It can measure both terrestrial and oceanic erosion. On the other hand, the TMEM can be used to track the expanding and contracting of volatile rock formations and can give a reading of how quickly a rock formation is deteriorating.

Tactics for preventing erosion in the future have been under investigation by scientists and geologists all over the world. Today, the most effective method for erosion prevention is soil surface cover. In this method, some type of permeable material, left over crop residue for example, covers the soil surface, which includes rock and sediment debris. This decreases the deteriorating capabilities of the impact from rain, animals, machinery, or any other type of eroding agent. As a result, surface runoff is controlled which helps eliminate the transportation of eroded particles elsewhere, thus slowing the process of erosion as a whole.



Tectonic effects



Figure 4.72
River eroding volcanic ash flow Alaska Southwest, Valley of Ten
Thousand Smokes

The removal by erosion of large amounts of rock from a particular region, and its deposition elsewhere, can result in a lightening of the load on the lower crust and mantle. This can cause tectonic or isostatic uplift in the region. Research undertaken since the early 1990s suggests that the spatial distribution of erosion at the surface of an orogen can exert a key influence on its growth and its final internal structure (see erosion and tectonics).

No do activity 1

Activity



Activity



How long?

Time Required: In this activity you need at most 45 minutes to fully answer the question.

ADD ACTIVITY PLEASE

Once done with the activity, please compare your answers with mine before you proceed.



Feedback

References

Reference

References for images

http://en.wikipedia.org/wiki/Peru-Chile_Trench

http://en.wikipedia.org/wiki/Mariana_Trench

<http://library.thinkquest.org/22752/Sea%20Structure/Ridge.html>

<http://www.physicalgeography.net/fundamentals/10l.html>

http://www.uwsp.edu/geo/faculty/ritter/geog101/textbook/tectonics_landforms/folding.html

<http://etc.usf.edu/maps/pages/3600/3636/3636.htm>

http://earthquake.usgs.gov/earthquakes/recenteqsww/Maps/world_moll/world_moll.gif

http://www.bbc.co.uk/schools/gcsebitesize/geography/images/tec_007.gif

http://visual.merriam-webster.com/images/earth/geology/earthquake/seismographs_2.jpg

http://commons.wikimedia.org/wiki/File:Kinematics_seismograph.jpg

http://wiki.answers.com/Q/How_does_an_earthquake_have_an_impact_on_people#ixzz1Oag4Qntm

EnchantedLearning.com

Wikipedia - Wave animation showing the initial "drawback" of surface water

(Photo by German Aerospace Center DLR/ZKI via Getty Images)

<http://library.thinkquest.org/TQ0312395/rof.gif>

<http://mail.colonial.net/~hkaite/Aaascienceimages2137/VolcanoStructure.jpg>

<http://www.angelfire.com/rings/mibu/images/T046050A.gif>

http://i1.treklens.com/photos/26649/finger_of_god.jpg

<http://upload.wikimedia.org/wikipedia/commons/b/b8/45172890.lud569.jpg>

http://www.klausdierks.com/images/Namibia.FishRiver_Canyon3.jpg

http://upload.wikimedia.org/wikipedia/commons/thumb/5/51/D%C3%BCne_S-Schlag_Sossusvlei.JPG/800px-D%C3%BCne_S-Schlag_Sossusvlei.JPG



Summary



Summary

In this unit you learned In this unit you learned

- The earth consists of three layers:
 - an outer layer called the crust
 - the mantle below the crust
 - the outer and inner core in the centre of the earth.
- The crust is a solid layer that floats on the molten mantle below. The movements of molten material in the mantle, called convection currents, dragged the crust along in different directions. This caused the crust to break up into different slaps, called plates. These plates can carry an ocean, a continent or both on them.
- Each plate has margins. Where two plates are moving away from each other, it forms a diverging or constructive margin, because new crust or sea floor is constructed by the outpouring of lava. This movement can cause mid-oceanic ridges to form on the ocean floor. If a continent lies on top of a divergent margin, a rift valley is formed in the continental crust, such as the Rift Valley in East Africa.
- Where two plates with different densities move towards each other, a converging or destructive margin is formed. The heavier, more dense, ocean plate is forced to dip below the lighter, less dense, continental crust. As the ocean plate is pushed deeper into the mantle, it starts to melt to become part of the magma in the mantle. The area where this plate dips down is called a subduction zone. On the sea floor a deep sea trench is formed where the oceanic plate starts to bend.
- Where two plates move alongside each other, either in different directions or in the same direction, but one plate moves faster than the other, a conservative margin is formed. Landforms are neither created nor destroyed. This is an area of earthquake activity, as the two plates can get stuck against each other and a lot of tension builds up. When this tension is suddenly released, an earthquake occurs. A good example is the San Andreas Fault line.
- When two plates collide, the material between them is crumpled up to form fold mountains. When oceanic and continental plates collide, fold mountains are formed on the edge of the continental plate and these are called peripheral fold mountains, for example, the Andes.
- When two continental plates collide, intercratonic fold mountains are formed, such as the Himalayas. These folds can occur in different forms: a monoclinical fold where slight tension came from one side; a symmetrical fold where the tension was applied equally from both sides; and an asymmetrical overfold, where tension from one side

was much stronger.

- Earthquakes occur along convergent and conservative plate boundaries. Earthquakes can cause lots of damage to buildings, roads, bridges, water pipes, electricity lines, etc. They can also kill people.
- Volcanoes occur along divergent plate boundaries. The molten rock inside the crust is called magma and when it starts to pour out onto the crust, it is called lava. The enormous pressure that builds up inside the earth is released along weak spots (cracks) in the crust. It forms a vent or pipe through which the molten magma is forced out onto the surface.
- Eruptions can occur with an explosion or the magma can just flow out and spread over the surface. This will build up either shield volcanoes or strato volcanoes. Volcanoes can have positive effects: they create very fertile soil after weathering takes place; they can be used to generate geothermal electricity; they bring diamonds and other minerals to the earth's surface and they attract tourists.
- Weathering, erosion and deposition change the crust of the earth.
- Weathering is the process that breaks up sediments into smaller parts, and erosion and deposition are the processes that remove and deposit this weathered material in other places.
- Weathering can be divided into mechanical weathering, where temperature (heat and cold) plays a very important role, chemical weathering where water is involved and biological weathering, where plants and animals are involved.
- Erosion is the process that removes this weathered material from its place of origin and deposits it in other areas. Running water, ice, the oceans and wind are very important agents of erosion. Wind deposits create sand dunes.

The focus is the exact spot deep inside the crust where the earthquake originates, and the epicentre is the area directly above the focus on the crust where the most damage occurs. The energy is released in the form of waves that travel through the crust. The P and S waves move through the crust and cause little damage. The L waves move on the crust and (information missing).

Assessment



Assessment

1. (a) Write a short sentence or phrase to give the meaning of the following concepts:
- (i) plate (1)
 - (ii) subduction zone (1)
 - (iii) volcanism (1)
 - (iv) earthquake (1)
 - (v) erosion (1)

(b) Study the diagram below and answer the questions.

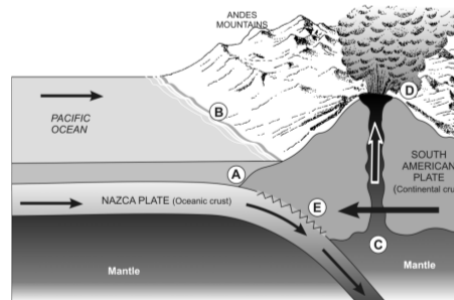

- (i) Identify the type of plate boundary. (1)
 - (ii) What do we call the zone at **A**? (1)
 - (iii) What landform can be created on the ocean floor at **B**? (1)
 - (iv) Explain how volcanoes are formed at this type of boundary. (2)
- (c) **The Figure below** shows a volcano. Study it and answer the questions.
- (i) Identify the parts labelled **A, B, C**. (3)
 - (ii) What problems can be caused by volcanic ash to people living nearby? (2)

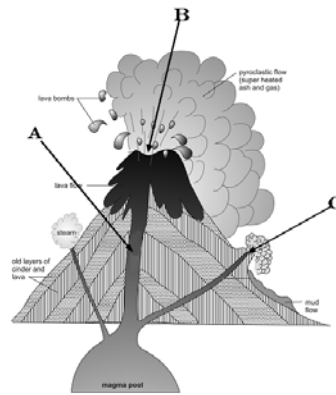

Assessment Feedback



Assessment

- (a) (i) **Plate** – sections or parts of the earth’s crust that is constantly moving. (1)
- (ii) **Subduction zone** – is an area where two plates collide. One plate is then forced to bend downwards below the other one into the mantle, where it slowly starts to melt again. (1)
- (iii) **Volcanism** – the process involved in the formation of volcanoes, and in the transfer of magma from the interior of the earth to its surface. (1)
- (iv) **Earthquake** – a violent shaking of the earth’s crust that may cause destruction to buildings and results from the sudden release of tectonic stress along a fault line or from volcanic activity. (1)
- (v) **Erosion** – it is the process that removes weathered materials from their place of origin to new locations. (1)
- (b) (i) Converging (destructive) boundaries (1)
- (ii) Subduction zone (1)
- (iii) Sea trench can be formed where the two plates meet. (1)
- (iv) The friction between the rocks generates heat which melts the plate material into magma. The pressure created can be released by volcanic eruptions on the surface of the crust. (2)
- (c) (i) **A** Vent pipe
B Crater (ejects pyroclastic flow, lava bombs)
C Conelet / Parasitic crater (3)
- (ii) Can cover the countryside with ash. It can kill livestock and cause famine. It can also hang in the earth’s atmosphere for a long time and is a serious threat to air traffic. (2)

Assignment 2



Assignment

SECTION A - ECOLOGY

Question 1

(a) Fig. 1 shows the advantages of trees and forests.

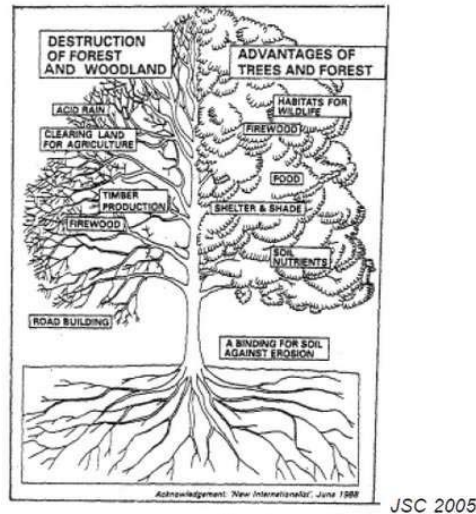

Fig. 1

(i) Give reasons why forests are important for

A - People

[1]

B - Wild animals

[1]

C - to prevent soil erosion

[1]

(ii) Explain why it is sometimes necessary to clear large areas covered by trees

A - Rural communities

[1]

B - Commercial purposes

[1]

(iii) Describe two problems that deforestation may cause for the environment.

[2]

(b) Fig. 2A shows areas in the world at risk of desertification and Fig. 2B shows some causes and problems created by desertification.

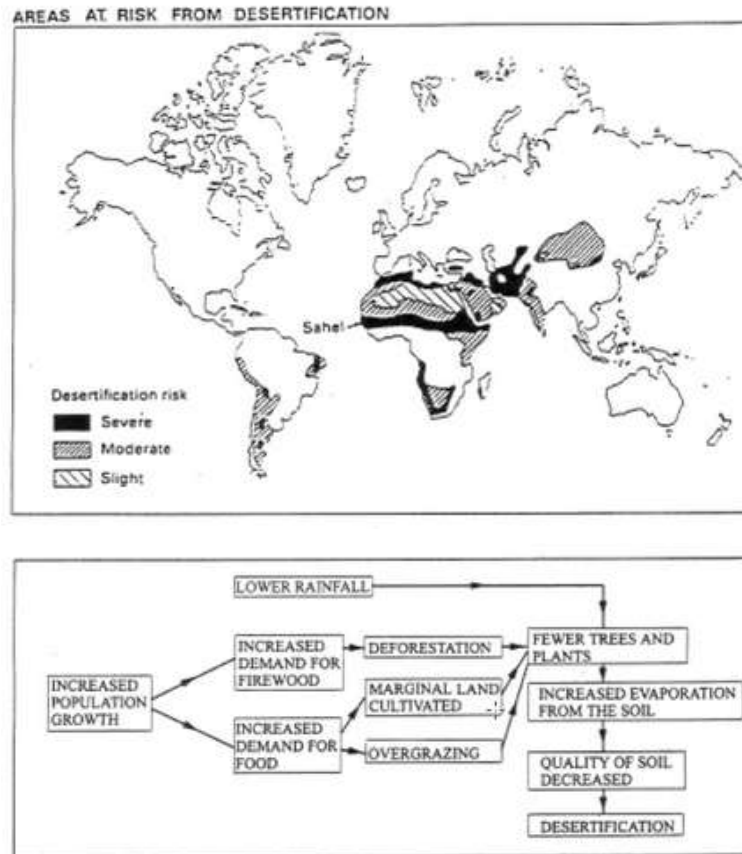

Fig. 2B

JSC 2000

[1]

(i) Which continent is at greatest risk of desertification? [1]

(ii) From Fig. 2B, suggest one human cause of desertification. [1]

(iii) From Fig. 2B, suggest one natural cause of desertification. [1]

(iv) By using Fig. 2B, explain why desertification is a difficult problem to solve. [1]

(v) The table below shows the percentage of the areas at risk of desertification. Use the information to complete the pie chart, which is half drawn. [3]

Areas at risk of desertification	%
Already desert	8
High risk	14
Moderate risk	12
Little or no risk	66

The pie chart is already divided into percentage segments. Use the key for the correct shading.

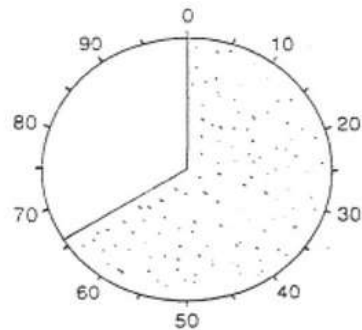

Key

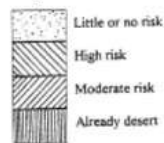

Question 2

(a) Fig. 3A shows changes in average global temperatures and Fig. 3B shows how the greenhouse effect works.

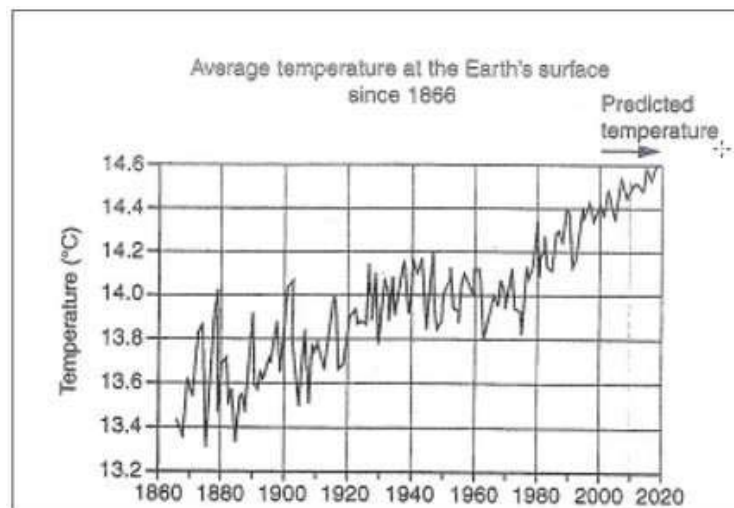

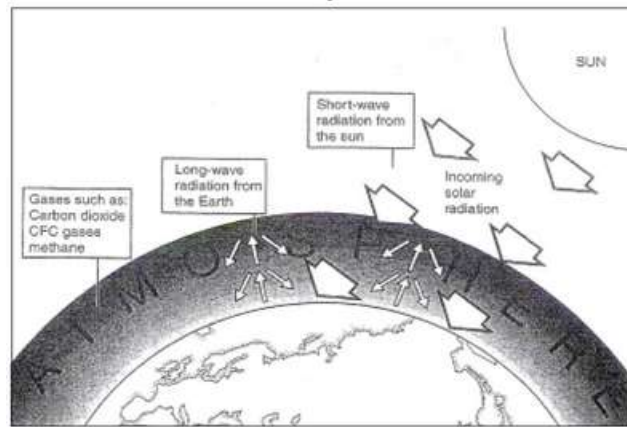

NSSC 2006

Fig. 3B

(i) According to the prediction in Fig. 3A, what will the average global temperature be in 2010? [1]

(ii) What has generally happened to global temperatures between 1860 and 2000? [1]

(ii) Use Fig.3B to explain how the greenhouse effect works. [3]

(iv) Name one greenhouse gas, apart from those given in Fig. 3B. [1]

(v) Explain how human activities may increase the amount of greenhouse gases in the atmosphere. [3]

(vi) Describe some of the problems, due to global warming, that might be experienced by low-lying coastal towns. [1]

(vii) Suggest three solutions to reduce the greenhouse effect in the

atmosphere.

[3]

(b) Fig. 4 shows one cause of acid rain.

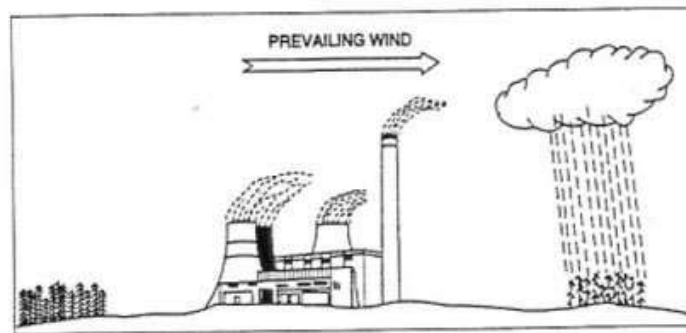

JSC 2002

Fig. 4

(i) Identify the source of pollution shown in the figure.

[1]

(ii) Name one gas released at the power station which causes this type of pollution.

[1]

(iii) Name the fossil fuel that is used in the power station.

[1]

(iv) Describe two ways in which acid rain poses a serious threat to people.

[2]

(v) Describe how acid rain can destroy forests.

[2]

(vi) Describe two other 'cleaner' methods of energy production that can be introduced by governments.

[2]

Brazil battles to hold back oil spill

Alex Bellos in Rio de Janeiro

Workers in southern Brazil were placing barriers across the Iguacu river and digging runoff channels to stop the country's worst river oil spill from reaching cities and the scenic Iguacu falls. About 4 million litres of crude oil spilled from a burst oil refinery pipe into a tributary of the Iguacu endangering drinking water, farm land and animal life.



CIE 2002

Fig. 6

(a) Describe how this oil spill poses a threat to humans. [2]

(b) What has been done to prevent the oil from reaching cities and the Iguacu waterfalls? [2]

(c) Why did the people try to prevent the oil from reaching the Iguacu waterfall? [2]

Total Marks for Section A: [50]

SECTION B - GEOMORPHOLOGY

Question 5

Fig. 7A is a map of the world's tectonic plates. Fig. 7B is a diagram of plate boundary B shown on Fig. 7A.

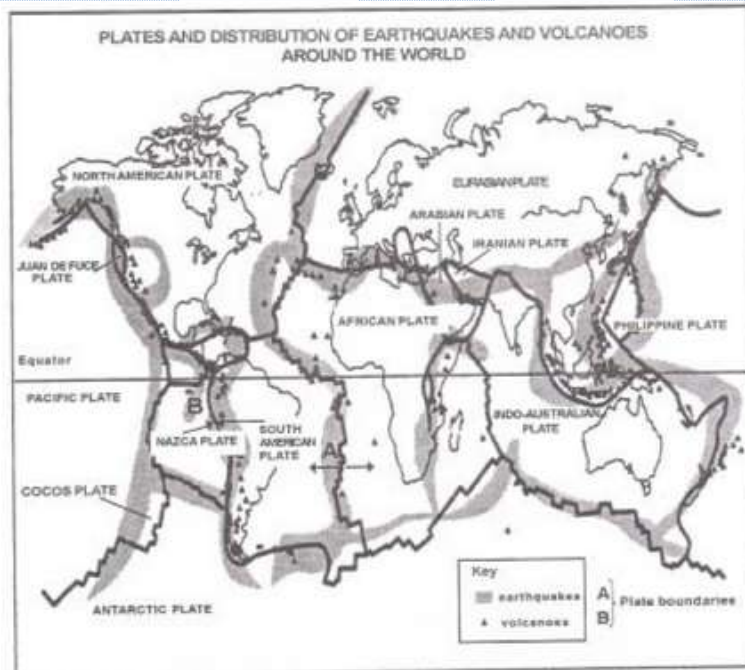

Fig. 7A

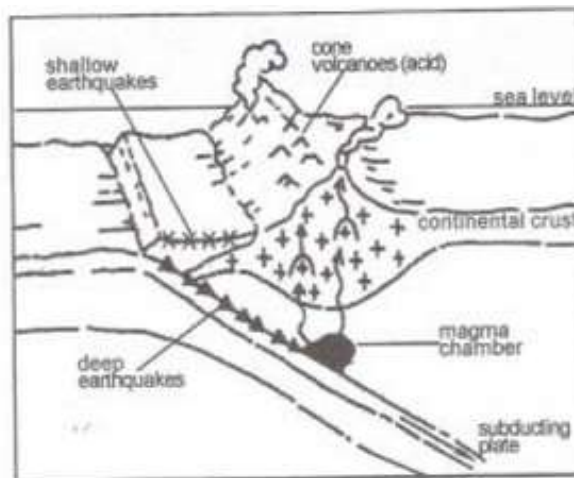

Fig. 7B

(a) (i) What is a tectonic plate? [2]

(ii) Briefly explain why plates move. [2]

(iii) What is meant with the term 'plate boundary'. [1]

(iv) Describe what coastal process is taking place at point A on Fig. 7A. [1]

(v) Describe how new crust is created at point A on Fig. 7A. [3]

(b) Refer to Fig. 7B.

(i) What type of plate boundary is shown in Fig. 7B. [1]

(ii) Give a reason for your answer in (i). [1]

(iii) Explain why earthquakes are likely to take place at these type of plate boundaries. [3]

QUESTION 6

(a) Study Figs. 8A and 8B below.

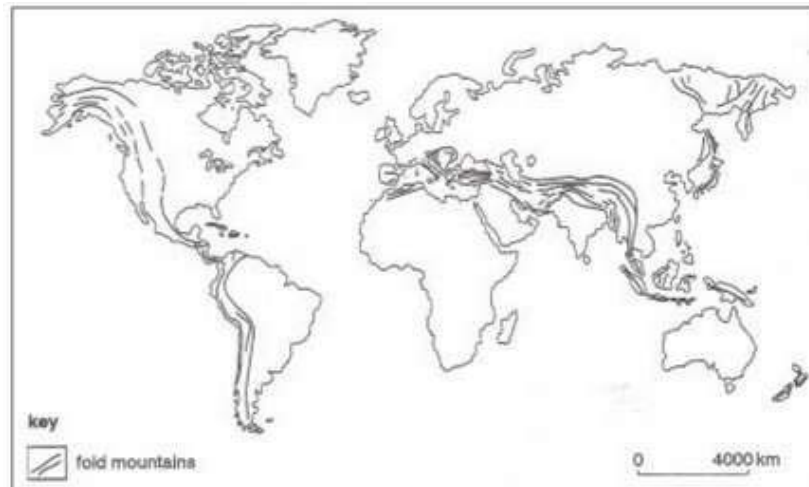
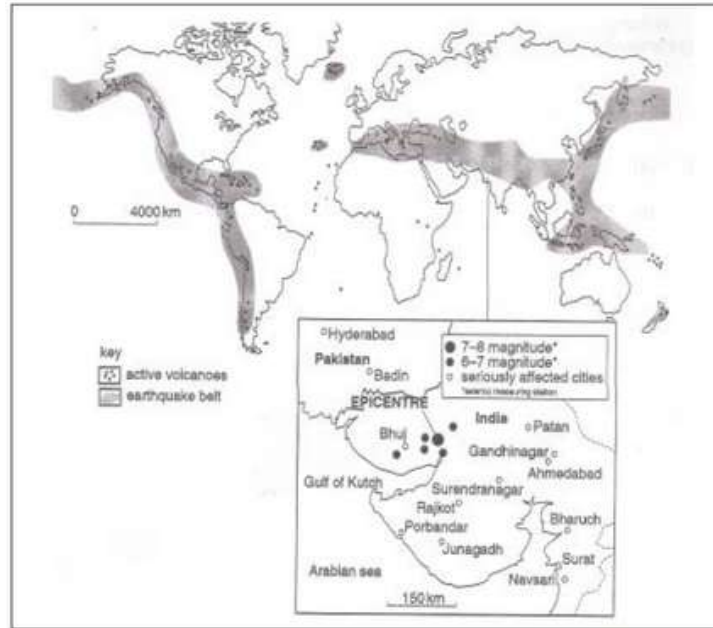

Fig. 8A

Fig. 8A



CIE 2003

Fig. 8B

(i) Describe the general distribution of fold mountains, earthquakes and volcanoes shown. [3]

(ii) Briefly explain why fold mountains, earthquakes and volcanoes are found in the areas described in (i). [3]

(iii) Use the insert in Fig. 8B, to explain why the city of Bhuj was more severely affected by the earthquake than the city of Patan. [2]

QUESTION 7

(a) Fig. 9 gives information about a major earthquake in Turkey in August 1999.

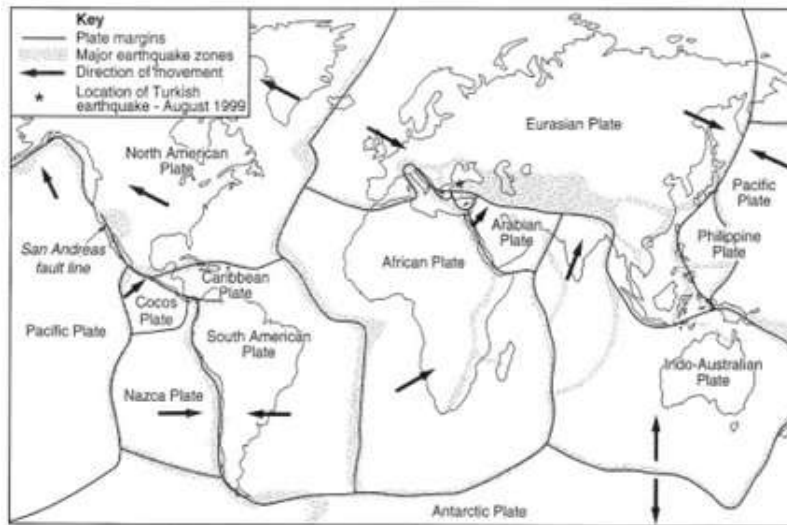

A Turkish earthquake kills thousands

An earthquake that struck north-western Turkey early on Tuesday morning left 15 000 dead and many injured.

Specialist teams dig through the night for survivors

Chris Morris in Ankara

Rescue workers were still tearing at the rubble early today, some with their hands, in a desperate effort to save thousands of people believed to be trapped in collapsed buildings across western Turkey, after one of the most devastating earth-quakes to strike the region in 20 years.

The death toll late last night stood at 15 000 but

was rising steadily as aid workers in some of Turkey's most populated and industrialised districts continued to pull bodies from wrecked buildings. Many people were crushed while asleep. Some of the bodies were shrouded in blankets and sheets from their own beds.

The earthquake lasted just 45 seconds. It happened at 03.02 hours. Many lived in poor districts where building regulations are often ignored. The epi-centre was near the industrial city of Izmit, about

90 km east of Istanbul. Turkish authorities placed the earthquake at 6.7 on the Richter scale.

In the space of 45 seconds, water and power supplies were cut across the region, roads and communication links destroyed and up to 100 000 people left homeless.

The result is a huge nightmare for relief services. Finding and treating survivors remains the priority, with damage to power, telephone and road networks hampering efforts to reach victims.

Tens of thousands of



people are now living in the open, either because their homes are destroyed or because they fear their buildings are unsafe to live in.

Fig. 9

(i) Explain what is meant with the following: [4]

The focus of an earthquake

The epicentre of an earthquake

The Richter scale

The seismograph

(ii) Use the information in Fig. 9 to explain how physical and human factors made the earthquake so devastating.

Physical factors

[4]

Human factors

[3]

(iii) What can people do to protect themselves from earthquakes? [4]

b) Study Fig. 10 which is a sketch of Mount Etna during a volcanic eruption in 1983.

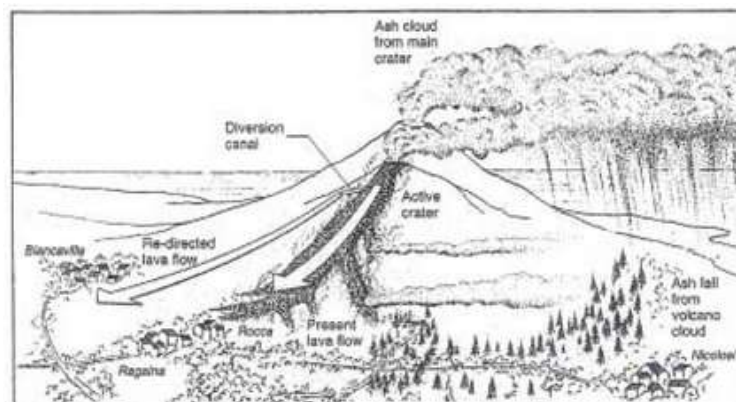

C/E 2005

Fig. 10

(i) Mount Etna is an active volcano. What does it mean? [1]

(ii) Identify the main hazard from the volcanic eruption which threatened:

A - Rocca and

Ragalna _____ [1]

B - Nicolosi _____ [1]

(iii) Describe how the volcanic activity has negatively impacted the lives of people who lived close to Mount Etna. [3]



(iv) Describe what can be done to protect people from volcanic eruptions. [3]

(v) Explain why many people choose to live near active volcanoes. [4]

Total Marks for Section B: [50]
Total Marks for Assignment 2: [100]

Assignment 2 Feedback



Assignment

Section A

Question 1

(a) (i)

A - People use trees for:

-fuelwood

-building material

-to make furniture

-paper for books (any 1)

[1]

B - Trees provide a habitat for wild animals, insects and birds.

[1]

C - Roots bind the soil against soil erosion.

[1]

(ii) A

Rural communities may need to clear forests to:

-build their villages/ houses

-plant crops

- heating / cooking purposes (any 1)

[1]

B Large areas may be cleared for

(commercial) crop production

-mining

-hydro-electric power stations

-cattle ranching

-logging / timber production

-road construction (any 1)

[1]

(iii) - Loss of medicines

- Decrease in soil fertility

- Land pollution by mining activities

- Increase in CO₂ levels causing the greenhouse effect

- Loss of land / homes belonging to indigenous people

- Loss / destruction of habitats for wildlife

- Soil erosion (any 2)

[2]

(b) (i) Africa

[1]

(ii) -Increased population growth

-Increased demand for firewood

- Increased demand for food
- Deforestation
- Cultivation of marginal land
- Overgrazing (any 1) [1]
- (iii) -Lower rainfall
- More evaporation from soil (any 1) [1]
- (iv) -Natural causes, e.g. lower rainfall and drought are beyond human control
- As long as population increases the demand for food and natural resources also increase. (any 1) [1]
- (v)

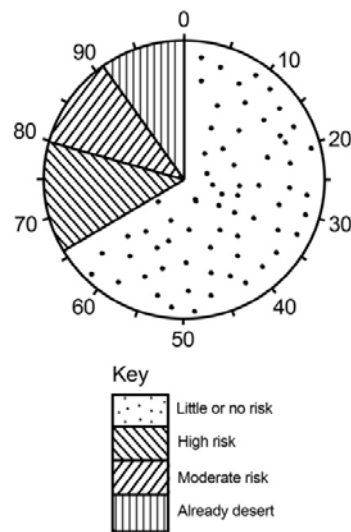

[3]

Question 2

- (a) (i) 14,5°C [1]
- (ii) Temperatures have increased. (but with fluctuations) [1]
- (iii) -Heat from the sun passes through the atmosphere / solar radiation
- It is radiated back from the surface
- Heat from the surface is trapped by layer of gases. [3]
- (iv) nitrous oxide / N₂O [1]
- (v) The following is produced by human activities:
 - Carbon dioxide from burning fossil fuels in vehicles, power stations and factories
 - CFC's are produced by fridges, aerosols, air conditioning systems
 - Methane from agriculture
 - Deforestation – increase CO₂ levels in atmosphere (any 3) [3]

- (vi) Low-lying coastal towns may be flooded. [1]
- (vii) -Controlling and reducing the burning of fossil fuels
 -Replanting forests that can absorb CO₂
 -Use renewable energy e.g. hydro-electricity, wind power, solar power
 -Reduce the use of CFCs by finding alternatives
 -Use unleaded fuel
 -Equip vehicles with catalytic converters
 -Buy electric cars
 -Improve technology (hybrid vehicles)
 -Reduce deforestation
- Also accept answers that explain what people can do to save electricity, e.g. switch off electrical appliances when not in use, provided explanations are given for it. (any 3) [3]
- (b) (i) power stations / factories [1]
 (ii) sulphur dioxide / nitrogen oxide [1]
 (iii) coal [1]
- (iv) -When people inhale acidic particles their lung tissues could be damaged.
 -Acidic particles may irritate eyes.
 -Smog reduces visibility which may cause car accidents / traffic jams.
 -Health risk to humans if they eat contaminated seafood. (any 2) [2]
- (v) -Acid rain may wash nutrients out of the soil / makes soil infertile
 -It weakens trees and limits their growth
 - It kills trees. (any 2) [2]
- (vi) -Use renewable energy from wind, water and sun
 -Burn natural gas because it creates less sulphur dioxide than coal. [2]
- Question 3**
- (a) (i) Occurs when open savannah / grassy areas become covered in dense woody plants. [1]
 (ii) black thorn / false umbrella thorn / mopane / sickle bush / silver terminalia (any 2) [2]
 (iii) -poor farming management
 -preventing forest fires means that woody plant species will grow abundantly and produce many seeds
 -bare areas that were cleared for cultivation quickly fill with bush species



-more grazing livestock leads to fewer browsing game animals which will allow bush to grow denser and form thickets

-subsidies to farmers to feed animals during drought encourage farmers to keep more animals which deplete grass further. (any 2) [2]

(iv) -Long, severe droughts

-Floods remove the fertile top soil making it difficult for grass to grow

-Kudu's graze on sickle bush and the seeds contained in kudu dung is spread over a vast area. (any 2) [2]

(v) -Boer goats browse on the leaves of bush species.

-They also debark the stem and branches.

-This will reduce their growth. (any 1) [1]

Question 4

(a) The oil spill

-endangered drinking water

-contaminated / pollutes farmland [2]

(b) Workers

-placed barriers across the Iguacu river

-dug run-off channels [2]

(c) The Iquacu waterfall

-is a major tourist attraction

-will spread oil further [2]

Total Marks for Section A [50]

Section B

Question 5

(a) (i) A huge section / part / piece of the earth's crust (~) that floats on the mantle.(~) [2]

(ii) Movement of convection currents in the mantle (~) drag and push the plates of the crust in different directions.(~) [2]

(iii) The edges of plates / where two plates meet/diverge. [1]

(iv) Plates are diverging / moving apart from each other. [1]

(v) -A gap forms as plates move apart

-Magma rises to the surface

-Lava cools and solidifies and new crust / ridges / volcanic islands/ is formed [3]

(b) (i) destructive / converging plate boundary [1]

(ii) It is destructive because an oceanic plate is subducted under a continental plate or two plates colliding with each other and crust is

destroyed. [1]

- (iii) -Plates are colliding / plates ride over each other
- Friction occurs between plates / plates hook onto each other
- Friction builds up and tension increases
- Build up of energy / pressure build-up
- Energy released and shockwaves are created. / plates jerk loose, sending out energy in the form of shockwaves. [3]

Question 6

- (a) (i) -They occur along plate boundaries
- Along the west coasts of North and South America
- Earthquakes and volcanoes are common along the Pacific Ring of Fire
- Volcanoes also occur in the Mid-Atlantic Ocean
- Fold mountains occur along edges of continents
- They also occur from South Europe through the Middle East to Southeast Asia Along East African Rift valley (any 3) [3]

(ii) -Continental movements occur along plate boundaries / unstable zones

- Pressure builds up due to plate movements
- Tension released through earthquakes / sudden movements
- High degree of active plate boundaries (any 3) [3]

- (iii) -The epicentre was closer to Bhuj than to Patan
- The magnitude was stronger at Bhuj than at Patan. [2]

Learners's answers must be comparative.

Question 7

(a) (i) Focus – exact point in the crust where the earthquake has started.

Epicentre – point on the crust directly above the focus.

Richter scale – Scale on which the strength of an earthquake is measured.

Seismograph – Instrument that records the force and direction of an earthquake. [4x1]

(ii) Physical factors

-the earthquake lasted 45 seconds

-it happened at 03h02 in the morning



- it measured 6.7 on the Richter scale
 - the epicentre was very close to the city of Izmit [4]
- Human factors
- the city was heavily populated
 - there were many buildings
 - building regulations were ignored
 - buildings were not earthquake resistant
 - people were asleep, no time to escape
 - rescue operations were hampered by damaged power, telephone and road networks (any 3) [3]
- (iii) -Scientists must monitor seismic activity.
- Early warnings must be given to people.
 - Early evacuation of the area in danger.
 - Prevent building on weak rock, e.g. reclaimed land from the sea.
 - Place rubber shock absorbers between the foundations and superstructure of buildings.
 - Use more flexible gas, water and power lines.
 - Plan and prepare people for emergency and evacuation procedures
 - Make sure that the rescue operation network and equipment is good
 - Greater public awareness / education in schools. (any 4) [4]
- (b) (i) Volcanoes that are likely to erupt / have erupted recently. [1]
- (ii) A – lava flow
B – ashfall [2]
- (iii) -People were killed
- People were injured
 - Loss of property
 - Farmland was damaged
 - People had to move away from their homes
 - Breathing problems (any 3) [3]
- (iv) -Emergency service plan should be in action

- Educate people on what to do during and after an eruption.
 - Scientists must monitor seismic activity.
 - Early warnings must be given to people.
 - Early evacuation of the area in danger.
 - Water can be sprayed on lava to cool it down and stop it.
 - Canals can be dug to divert or stop lava flow.
 - Concrete blocks can divert or stop lava flow.
- People must wear protective clothing (e.g. goggles/ face masks) to protect them from volcanic ash. (any 3) [3]

- (v) -Fertile soil formed by ash and lava
- tourist attractions
 - lava flows create new land
 - fumaroles contain mineral deposits
 - diamonds are brought to the surface through volcanic activity
 - volcanic material(pumice lava) is used in household products, e.g. toothpaste
 - hot springs and fumaroles are used for geothermal energy
 - geysers, hot springs are tourist attractions (any 4) [4]

Total marks for Section B: [50]

Total marks for Assignment 2: [100]



Unit 5

Population Geography

Introduction

Welcome to population geography. In this unit we will look at factors that affect the growth of a population, densely and sparsely populated areas, factors that lead to rapid population growth, the demographic transition model and population pyramids. Explain terms such as fertility, mortality and migration and the factors that influence fertility, mortality and migration. Other aspects that we will look at are rural-urban migration, social standards, pressure on natural resources, provision of services, rapid population growth, dependency ratio and infrastructure. But before we continue with the discussion I want you to look at the unit outcomes first.

Upon completion of this unit you should be able to:



Outcomes

- *identify* and give reasons for densely populated areas in the world;
- *identify* and give reasons for sparsely populated areas in the world;
- *describe* the population distribution and density of Namibia;
- *explain / give reasons* for the population distribution and density of Namibia;
- *explain / give reasons* for the rapid growth of world population since 1950;
- *identify* the largest cities in the world in terms of their population numbers;
- *explain and give reasons* for the rapid growth of population in Namibia;
- *use* the Demographic Transition Model to calculate birth rates, death rates and natural increase;
- *understand* why population growth is categorised in different stages of the model;
- *describe and explain* the shape of population pyramids corresponding with each stage of the model;
- *use* population pyramids to calculate birth rates, death rates, infant mortality rates, life expectancy and the sizes of different age groups of a population;
- *use* population pyramids to determine if a country is a More Economically Developed Country (MEDC) or a Less Economically Developed Country (LEDC);
- *explain* the terms Fertility, Mortality and Migration;

- *explain* the factors that influence fertility, mortality and migration.
- *describe* how population growth can affect the following positively or negatively:
 - ▣ rural-urban migration, social standards, pressure on natural resources, provision of services, rapid population growth, dependency ratio, infrastructure;
- *describe* how successful the following strategies are which were implemented to reduce the spread and impact of HIV and AIDS in Namibia:

Awareness campaigns, gender equality, anti-retroviral drugs, social services to orphans.

Now that you have studied the outcomes and know what is expected of you I want you to look at the timeframe first to see how much time is needed to complete this unit.



How long?

You will need approximately 25 hours to complete the unit.

Now that you have familiarize yourself with the time study the following terminologies first.



Terminology

Population distribution:	The way in which people are spread out across the world.
Population density:	The number of people per km ² .
Birth rate:	The number of babies born per 1000 people per year.
Death (Mortality) rate:	The number of people per 1000 who die in a year.
Natural increase:	The rate at which the population of a country is growing.
Infant mortality rate:	The number of babies who die in their first year of life per 1000 births per year.
Fertility rate:	The number of young children in relation to the number of women in their fertile age in a population.
Life expectancy:	The number of years that a person can expect to live.
Literacy rate:	The percentage of the total population that can read and write.

Migration:	The movement of people from one place to another.
Gross National Product (GNP):	The total value of all the goods and services produced in a country in one financial year.
GNP per capita:	The GNP divided by the total number of people in a country.

Section 1

Population density and distribution

This section explains why certain areas in the world, including some areas in Namibia, have very dense populations while other areas are sparsely populated. Study the section outcomes first.

Upon completion of this section you should be able to:

- *identify* on a map the major population clusters in the world and in Namibia;
- *explain* the factors that influence population distribution;
- *explain* the factors that influence population density.



Section outcomes

Population density 2006

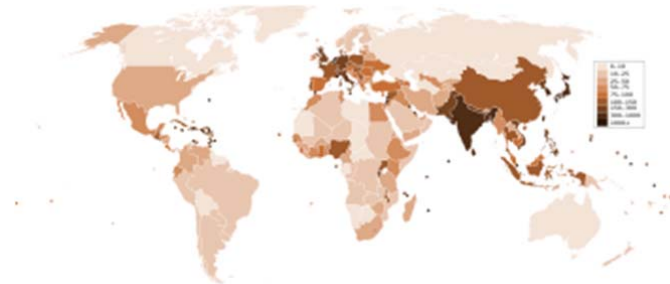

Figure 5.1

Source: http://en.wikipedia.org/wiki/Population_density

For humans, population density is the number of people per unit of area usually per square kilometre (which may include or exclude cultivated or potentially productive area). Commonly this may be calculated for a county, city, country, another territory, or the entire world.

The world's population is 6.8 billion, and Earth's total area (including land and water) is 510 million square kilometers. Therefore the worldwide human population density is $6.8 \text{ billion} \div 510 \text{ million} = 13.3 \text{ per km}^2$. If only the Earth's land area of 150 million km^2 is taken into account, then human population density increases to 45.3 per km^2 . This calculation includes all continental and island land area, including Antarctica. If

Antarctica is also excluded, then population density rises to 50 people per km². Considering that over half of the Earth's land mass consists of areas inhospitable to human habitation, such as deserts and high mountains, and that population tends to cluster around seaports and fresh water sources, this number by itself does not give any meaningful measurement of human population density.

Several of the most densely-populated territories in the world are city-states, microstates, micro nations, or dependencies. These territories share a relatively small area and a high urbanization level, with an economically specialized city population drawing also on rural resources outside the area, illustrating the difference between high population density and overpopulation.

Cities with high population densities are, by some, considered to be overpopulated, though the extent to which this is the case depends on factors like quality of housing and infrastructure and access to resources. Most of the most densely-populated cities are in southern and eastern Asia, though Cairo and Lagos in Africa also fall into this category.

City population is, however, heavily dependent on the definition of "urban area" used: densities are often higher for the central municipality itself, than when more recently-developed and administratively unincorporated suburban communities are included, as in the concepts of agglomeration or metropolitan area, the latter including sometimes neighboring cities. For instance, Milwaukee has a greater population density when just the inner city is measured, and not the surrounding suburbs as well. http://en.wikipedia.org/wiki/Population_density



In-text question

Can you think of factors that has some influence on population distribution and density?

Population Distribution

Population distribution means the pattern of where people live. World population distribution is uneven. Places which are sparsely populated contain few people. Places which are densely populated contain many people. Sparsely populated places tend to be difficult places to live. These are usually places with hostile environments e.g. Antarctica. Places which are densely populated are habitable environments e.g. Europe.

Population Density

Population density is a measurement of the number of people in an area. It is an average number. Population density is calculated by dividing the number of people by area. Population density is usually shown as the number of people per square kilometer. The map below is a choropleth (shading) map and illustrates population density. The darker the colour the greater the population density.

<http://www.geography.learnontheinternet.co.uk/topics/popn1.html>



The map above shows that world population distribution is uneven. Some areas have a high population density while others have a low population density. Areas of high population density tend to be located between 20° and 60°N. This area contains a large land area and a relatively temperate climate.

Factors Affecting Population Density

There are a range of human and natural factors that affect population density. The tables below illustrate this.

Physical Factors	High Density	Low Density
Relief (shape and height of land)	Low land which is flat e.g. Ganges Valley in India	High land that is mountainous e.g. Himalayas
Resources	Areas rich in resources (e.g. coal, oil, wood, fishing etc.) tend to be densely populated e.g. Western Europe	Areas with few resources tend to be sparsely populated e.g. The Sahel
Climate	Areas with temperate climates tend to be densely populated as there is enough rain and heat to grow crops e.g. UK	Areas with extreme climates of hot and cold tend to be sparsely populated e.g. the Sahara Desert

Human Factors	High Density	Low Density
Political	Countries with stable governments tend to have a high population density e.g. Singapore	Unstable countries tend to have lower population densities as people migrate e.g. Afghanistan.
Social	Groups of people want to live close to each other for security e.g. USA	Other groups of people prefer to be isolated e.g. Scandinavians
Economic	Good job opportunities encourage high population densities, particularly in large cities in MEDCs and LEDCs around the world.	Limited job opportunities cause some areas to be sparsely populated e.g. Amazon Rainforest

Population Change

The world's population is growing very rapidly. In 1820 the world's population reached 1 billion. In 1990 it reached 6 billion people.

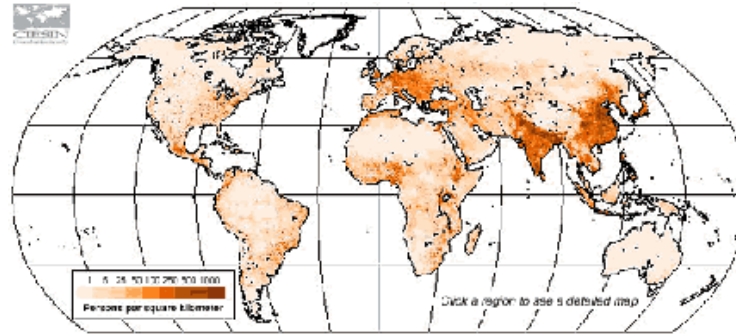

Figure 5.2

Source: <http://www.geography.learnontheinternet.co.uk/topics/popn1.html>

This rapid growth in population has been called a **population explosion**.

The major reason for population changes, whether in an individual country or for the whole world, is the change in birth and death rates. The **birth rate** is the number of live babies born in a year for every 1000 people in the total population. **Death rates** are number of people dying per 1000 people. When birth rates are higher than death rates the population of an area will increase.

Over the past 150 years improvements in **health care** and **sanitation** around the world have led to a drop in the death rate. While birth rates have dropped in MEDCs, birth rates are still high in LEDCs. Therefore the number of people in the world has grown rapidly.

Life Expectancy

Life expectancy is the average age a person can expect to live to in a particular area. Life expectancy can be used as an indicator of the overall 'health' of a country. From this figure you can determine many features of a country e.g. standard of living. As a general rule the higher the life expectancy the more healthy (or developed) a country is.

Activity



Activity

Time Required: In this activity you need at most 45 minutes to fully answer the question.



How long?

ADD ACTIVITY PLEASE

Once done with the activity, please compare your answers with mine before you proceed.



Feedback

What are the factors affecting the distribution of population?

The factors affecting population are numerous however there are a few general but important ones.

1. The Climate of the Area- if the area is grassland or forested then it has a low population density because these areas are prone to rainfall in dry or desert areas there is also a low population density as the climate is too dry.

2. Mineral Resources- persons tend to live near areas that they are able to access employment easily for example in mining or bauxite areas e.g. Kirkvine Manchester Jamaica or also in the business sector.

3. Births -every time many babies are born in different places and countries and many more. Birth rates are increasing because of many people that are ready to have children.

4. Deaths -death rates are slower because of proper sanitation, proper nutrition, and proper health. This means more people are away of death and more people will stay in the population.

1. Physical Features
2. Agriculture
3. Fresh Water
4. Available Power
5. Access to Other Communities

http://wiki.answers.com/Q/What_are_the_factors_affecting_the_distribution_of_population

Atmosphere disturbance:

Storms, cyclones, earthquake volcanism are common in some areas. So people fear to live in those areas. Population density remains low there.

Physiographic:

Mountain: In mountain areas population is very low because of unavailability of resources. Transport style is not there.

Plain: In plains every facility is available. So population density is very high in plain areas

Plateau: In plateau population is moderate.

Desert: In desert areas population density is very low because unavailability of water

Section 2

Population Growth

In this section we will briefly discuss the difference between developed and developing countries.

Upon completion of this section you should be able to:



Section outcomes

- *explain* the fast growth in the world, as well as in Namibian, population since 1950;
- *identify* cities with more than a million inhabitants on a map of Africa;
- *explain* different patterns of growth in Namibia's population.

The **world population** is the total population of humans on the planet Earth, **currently estimated to be 6.915128 billion** by the United States Census Bureau. The world population has experienced continuous growth since the end of the Bubonic Plague around the years 1348-1350. The highest rates of growth—increases above 1.8% per year—were seen briefly during the 1950s, for a longer period during the 1960s and 1970s; the growth rate peaked at 2.2% in 1963, and declined to 1.1% by 2009. Annual births have reduced to 140 million since their peak at 173 million in the late 1990s, and are expected to remain constant, while deaths number 57 million per year and are expected to increase to 80 million per year by 2040. Current projections show a continued increase of population (but a steady decline in the population growth rate) with the population expected to reach between 7.5 and 10.5 billion in the year 2050. http://en.wikipedia.org/wiki/World_population

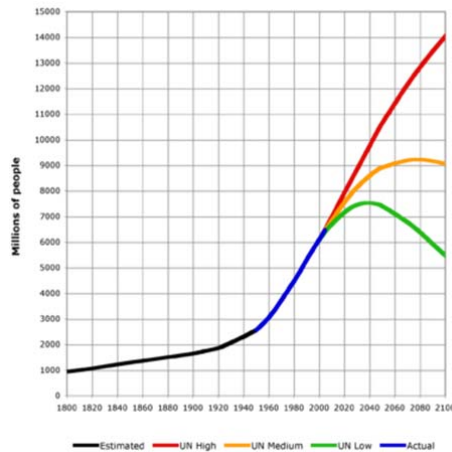

Figure 5.3
 Source; http://en.wikipedia.org/wiki/World_population

Largest populations by country

The 10 countries with the largest total population:

Rank	Country / Territory	Population	Date	% of world population	Source
1	People's Republic of China ^[54]	1,343,710,000	April 29, 2011	19.4%	Chinese Official Population Clock
2	India	1,210,193,422	March 2011	17%	[2]
3	United States	311,253,000	April 29, 2011	4.5%	United States Official Population Clock
4	Indonesia	238,400,000	May 2010	3.39%	SuluhNusantara Indonesia Census report
5	Brazil	194,576,000	February 29, 2011	2.81%	Brazilian Official Population Clock
6	Pakistan	175,887,000	April 29, 2011	2.54%	Official Pakistani Population clock
7	Bangladesh	164,425,000	2010	2.38%	2008 UN estimate for year 2010
8	Nigeria	158,259,000	2010	2.29%	2008 UN estimate for year 2010
9	Russia	141,927,297	January 1, 2010	2.05%	Federal State Statistics Service of Russia
10	Japan	127,380,000	June 1, 2010	1.84%	Official Japan Statistics Bureau

Figure 5.4
 Source: http://en.wikipedia.org/wiki/World_population

Densest populations by country

The 10 most densely populated countries/regions

Rank	Country/Region	Population	Area (km ²)	Density (Pop per km ²)
1	 Monaco	32,719	1.95	16,779
2	 Singapore	5,076,700	707.1	6,535
3	 Vatican City	824	0.44	1,873
4	 Maldives	385,375	298	1,293
5	 Malta	404,032	316	1,279
6	 Bahrain	723,967	665	1,089
7	 Bangladesh	157,813,124	147,570	1,069
8	 Palestinian territories	4,223,760	6,020	702
9	 Nauru	13,918	21	663
10	 Republic of China (Taiwan)	22,955,395	36,190	634

Figure 5.5

Source: http://en.wikipedia.org/wiki/World_population

Population Growth

This lesson will introduce you to some basic concepts of population growth and allow you to experiment with them using the included Java applets.

The term "population growth" refers to how the number of individuals in a population increases (or decreases) with time. This growth is controlled by the rate at which new individuals are added to the population -- the birth rate, and the rate at which individuals leave the population -- the death rate.

There are many types of plants and animals, and different types show different kinds of population growth. In this lesson we will consider a very simple type of growth where the animals in one generation give birth to the next generation and then die. Because the parents die immediately after giving birth, at any given time all individuals in a population are of the same age. This pattern of reproduction is very common in insects and some species of fish.

The number of children a parent gives birth to is known as the birth rate. If all individuals in a population have two children then the birth rate will be 2. However, it is not necessary for the birth rate to be a whole number such as 1, 2, 3, etc. For example, if half the individuals of the population have 2 children and the other half has 3, then on average the birth rate will be 2.5. Likewise, if the population consists of equal numbers of males and females, and if the females give birth to 3 children each (and the males 0), then the average birth rate of the population will be 1.5.

With these basics we can now consider two simple models of population growth:

- Exponential Growth
- Logistic Growth.

These pages describe each growth model and provide several experiments you can perform using the included Java applets. The experiments will help you to better understand that type of population growth. Follow the links and do the experiments there before returning to the discussion below.

Discussion

One of the greatest dangers planet Earth faces today is that of over-population by humans. Since the beginning of human history our population has been growing exponentially (actually a little faster than exponentially). However, there is now little additional land that can be put into use for food production and our wastes are rapidly polluting the environment. Unless major technological breakthroughs are made, we are close to the Earth's carrying capacity.

Compounding the problem is the fact that our average birth rate is still very high (greater than 2.0). It is possible we will overshoot the Earth's carrying capacity and for the first time in recorded history have massive population decline brought on by disease and starvation. You have seen how sensitive a population's growth is to its birth rate. The decrease in birth rate needed to avert a disaster is not large, but it is one that everyone needs to work on together to achieve.

<http://www.otherwise.com/population/index.html>

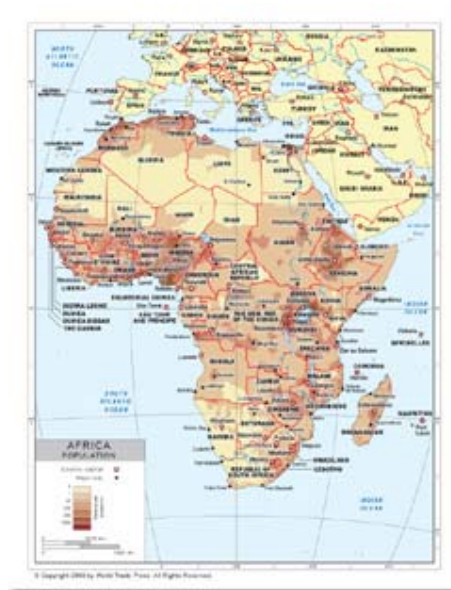

Figure 5.6



Activity

Time Required: In this activity you need at most 45 minutes to fully answer the question.

Activity



ADD ACTIVITY PLEASE

How long?

Once done with the activity, please compare your answers with mine before you proceed.



Feedback

Section 3

The Demographic Transition Model

Birth and death rates are responsible for changes in a country's population growth. If the birth rate is higher, the population will increase.

If the death rate is higher, the population will decrease. Upon completion of this section you should be able to:

- *calculate* birth rates, death rates and population growth from a demographic transition model;
- *understand* why populations are classified in different stages according to the model.



Section outcomes

The Demographic Transition Model

The **Demographic Transition Model** attempts to show how population changes as a country develops.

The model is divided into four stages.

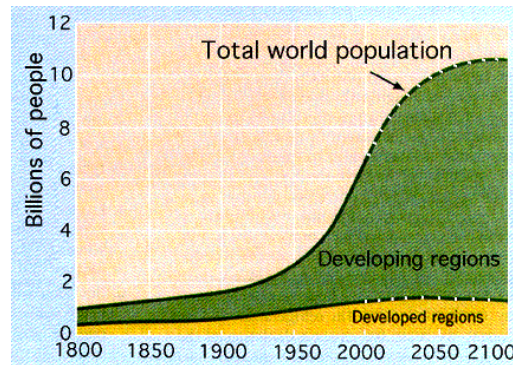

Figure 5.7

Source: <http://www.geography.learnontheinternet.co.uk/topics/popn1.html>

This rapid growth in population has been called a **population explosion**.

The major reason for population changes, whether in an individual country or for the whole world, is the change in birth and death rates. The **birth rate** is the number of live babies born in a year for every 1000 people in the total population. **Death rates** are number of people dying per 1000 people. When birth rates are higher than death rates the population of an area will increase.

Over the past 150 years improvements in **health care** and **sanitation** around the world have led to a drop in the death rate. While birth rates have dropped in MEDCs, birth rates are still high in LEDCs. Therefore the number of people in the world has grown rapidly.

Life Expectancy

Life expectancy is the average age a person can expect to live to in a particular area. Life expectancy can be used as an indicator of the overall 'health' of a country. From this figure you can determine many features of a country e.g. standard of living. As a general rule the higher the life expectancy the more healthy (or developed) a country is.

The Demographic Transition Model

The **Demographic Transition Model** attempts to show how population changes as a country develops.

The model is divided into four stages.

The Demographic Transition

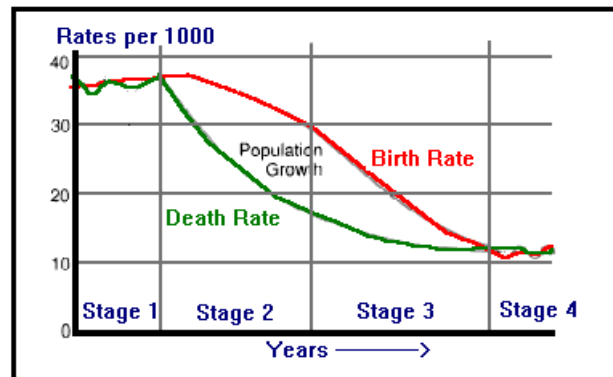

Figure 5.8

Source: <http://www.geography.learnontheinternet.co.uk/topics/popn1.html>

Stage 1

Birth rate and death rate are high - low natural increase - low total population

Stage 2

Birth rate is high - death rate is falling - high natural increase (population growth)

Stage 3

Falling birth rate - low death rate - high natural increase (population growth)

Stage 4

Birth rate and death rate is low - low natural increase - high total population

The Demographic Transition Model does not take into account migration.

Population Structure / Population Pyramids

The population structure for an area shows the number of males and females within different age groups in the population. This information is displayed as an age-sex or population pyramid. Population pyramids of LEDCs (Less Economically Developed Countries) typically have a wide base and a narrow top. This represents a high birth rate and high death rate. Population pyramids of MEDCs (More Economically Developed Countries) typically have a roughly equal distribution of population throughout the age groups. The top obviously gets narrower as a result of deaths. Population pyramids are used to show the structure of the population according to age and sex.

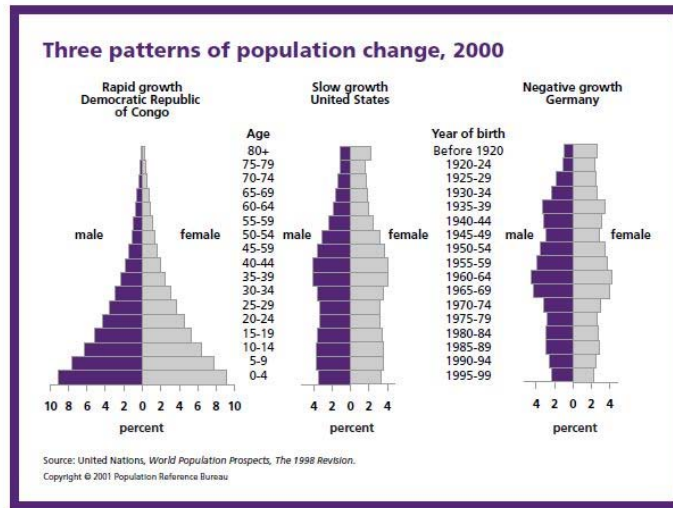

Figure 5.9

Source: <http://www.geography.learnontheinternet.co.uk/topics/popn1.html>

Now do activity 1

Activity



Time Required: In this activity you need at most 45 minutes to fully answer the question.

Activity

ADD ACTIVITY PLEASE



How long?

Once done with the activity, please compare your answers with mine before you proceed.



Feedback

Section 4

Population Pyramids

You have studied the growth of populations through an increase or decrease in their birth and death rates. You have also studied factors that affect these rates in different countries. To get an overall view of a country's population, the different ages and genders (male or female) of people in each age group must be recorded. This age and gender structure of a population is called the population structure of a country, and is drawn as a population pyramid.

Upon completion of this section you should be able to:



Section outcomes

- *calculate* birth and death rates, infant mortality rates, life expectancy and age groups of a population by using a population pyramid;
- *determine* from a population pyramid if a country is in the developing or developed stage.

A **population pyramid**, also called an **age structure diagram**, is a graphical illustration that shows the distribution of various age groups in a human population (typically that of a country or region of the world), which ideally forms the shape of a pyramid when the region is healthy. It is also used in Ecology to determine the overall age distribution of a population; an indication of the reproductive capabilities and likelihood of the continuation of a species.

It typically consists of two back-to-back bar graphs, with the population plotted on the X-axis and age on the Y-axis, one showing the number of males and one showing females in a particular population in five-year age groups (also called cohorts). Males are conventionally shown on the left and females on the right, and they may be measured by raw number or as a percentage of the total population.

Population pyramids are often viewed as the most effective way to graphically depict the age and sex distribution of a population, partly because of the very clear image these pyramids present.

A great deal of information about the population broken down by age and sex can be read from a population pyramid, and this can shed light on the extent of development and other aspects of the population. A population pyramid also tells how many people of each age range live in the area. There tends to be more females than males in the older age groups, due to females' longer life expectancy.

A helpful analogy to facilitate understanding population pyramids is that just as a builder employs a blueprint for showing a house's structure, demographers and geographers employ population pyramids as a blueprint for showing population dynamics.

http://en.wikipedia.org/wiki/Population_pyramid

Types of population pyramid

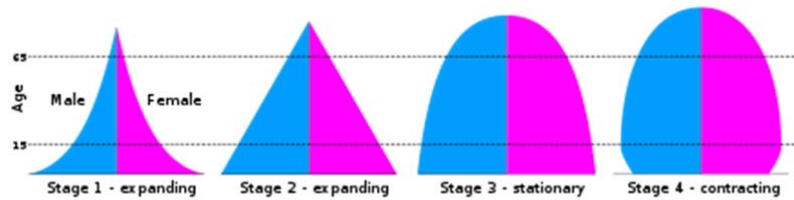

Figure 5.10

Population pyramids for 4 stages of the demographic transition model

While all countries' population pyramids differ, four general types have been identified by the fertility and mortality rates of a country.

Stable pyramid - A population pyramid showing an unchanging pattern of fertility and mortality.

Stationary pyramid - A population pyramid typical of countries with low fertility and low mortality, very similar to a constrictive pyramid.

Expansive pyramid - A population pyramid showing a broad base, indicating a high proportion of children, a rapid rate of population growth, and a low proportion of older people. This wide base indicates a large number of children. A steady upwards narrowing shows that more people die at each higher age band. This type of pyramid indicates a population in which there is a high birth rate, a high death rate and a short life expectancy. This is the typical pattern for less economically developed countries, due to little access to and incentive to use birth control, negative environmental factors (for example, lack of clean water) and poor access to health care.

Constrictive pyramid - A population pyramid showing lower numbers or percentages of younger people. The country will have a greying population which means that people are generally older, as the country has long life expectancy, a low death rate, but also a low birth rate. This pyramid has been occurring more frequently, especially when immigrants are factored out, and is often a typical pattern for a very developed country, a high over-all education and easy access and incentive to use birth control, good health care and a low number to no negative environmental factors.

Activity



Activity

Time Required: In this activity you need at most 45 minutes to fully answer the question.



How long?

ADD ACTIVITY PLEASE

Once done with the activity, please compare your answers with mine before you proceed.



Feedback

Section 5

Fertility, Mortality and Migration

This section deals with factors that influence fertility, mortality and migration rates both positively and negatively.

Upon completion of this section you should be able to:

- *explain* fertility, mortality and nett migration;
- *discus* factors that will influence fertility, mortality and nett migration.



Section outcomes

Fertility refers to births.

Mortality refers to deaths

Nett Migration refers to the difference between immigration and emigration or immigration minus emigration.

The above mentioned concepts can also be expressed as a rate.

Fertility rate refers to the number of young children in relation to the number of women of fertile age in the population.

Activity 1



Activity

Time Required:

In this activity you need at most 20 minutes to fully answer the question.



How long?

ACTIVITY: The two photographs below is an illustration of one woman of fertile age (under 50 years) and another one of infertile age (above 50 years).

Photo A- under 50



Photo B- above 50 years



Activity: Find out from your life science teacher or parents why women older than 50 years cannot bear children anymore.

Once done with the activity, please compare your answers with mine before you proceed.



Feedback

Mortality rate – refers to the number of deaths per thousand people per year.

Formula to calculate mortality rate:

$$\text{MR} = \frac{\text{Number of deaths per annum} \times 1000}{\text{total population}}$$

Nett Migration rate refers to emigration minus immigration per 1000 per year.

Emigration is when people leave their own country permanently.

Immigration is the movement of people into a country to stay permanently.

Activity: Is immigration, in general, greater than emigration? Discuss.

Factors influencing fertility

(a)Wealth: Poor rural populations have higher fertility rates, especially in developing countries. They need children to work on the fields and to take care of the old-age when they can no longer work. For some people it is a status to have many children.

(b)Medical care: Advance medical facilities leads to a decrease in infant mortality. Infertility is also reduced by technology causing higher birth rate.

(c)Birth control: Many people start using birth control measures. In some parts of the world sterilization is legalized. People practice family planning and use contraceptives.

(d)Education: People with a higher level of education will tend you have smaller families. Educated women will marry later and will have fewer children. Emancipation of women contributed to a decrease in fertility rate, because women also see material possessions like cars houses etc as very important.

(e)Religion: Many religions are opposed to the use of contraception e.g. Muslims and Roman Catholics. Young girls marry at the age of 16 and result is many child bearing years.

(f)Wars : It can lead to great loss of lives and eventually decreasing birth rates.

(g)Government policies: Governments can encourage people to have fewer children or introduce policies to reduce birth rates e.g. in China a one child policy was introduced. Some governments also urge couples to have more children to prevent ageing populations.

Factors influencing mortality rates

(a)Medical service: A lack of medical service increases the mortality rate especially in rural areas. Some people live in unhygienic conditions and in poverty. It means many could not afford basic services.

(b)Wealth: Death rate is usually higher in a less affluent section of the population than it is the more affluent section. Unemployment droughts, floods and diseases are some of the hardships that poor people should endure.

(c)Age structure: When a country has a very high percentage of old people, the death rate could be high.



(d)Wars: Wars will increase the death rates.

FACTORS INFLUENCING NETT MIGRATION

Pull factors	Factors	Push factors
Possible job opportunities	Employment	Scarcity of employment
Better education	Education	Poor education
Good services	Medical service	Poor services
Good housing	Housing	Lack of housing
Less natural disasters	Natural disasters	Occur often
Good weather	Climate	Harsh climates
Plenty of facilities	Entertainment facilities	Lack of facilities

Activity



Time Required: In this activity you need at most 45 minutes to fully answer the question.

Activity



ADD ACTIVITY PLEASE

How long?

Once done with the activity, please compare your answers with mine before you proceed.



Feedback

Section 6

Benefits and problems of population growth

In this section we will look at the positive and negative effects of population growth on the natural environment, resources and infrastructure of a country.

Upon completion of this section you should be able to:



Section outcomes

- describe the positive and negative aspects of population change in terms of:
 - rural-urban migration
 - rapid population growth
 - social standards
 - dependency ratio
 - pressure on natural resources
 - infrastructure
 - provision of services.

(a) **Rural – urban migration**

The influx of people from rural to urban centers is tremendous. This phenomenon leads to the rapid expanding of urban areas.

A rapid population increase contributes to lack of space and shortage of resources and services.

Reasons for rural – urban migration

- droughts, floods
- lack of jobs/low salaries
- harsh climates
- poor housing
- lack of medical services
- poor educational institutions
- retired and retrenched farm workers

Urban problems

- Unemployment
- Squatter camps
- Lack of housing
- Pollution
- traffic congestion
- social problems



(b) **Rapid population growth**

- overpopulation
- overcrowded services
- depletion of resources which may lead to poverty (hunger and starvation)
- degradation of environment
- unemployment
- strain on services

Besides the negative impact of rapid growth, it also has positive results.

It provides a labour force and prevents an ageing population.

(c) **Infrastructure and services**

Namibia has a very good infrastructure in some areas, but on the other hand, in many parts of the country, it is still a matter of great concern.

As the population increases, it puts a burden on the infrastructure.

Our infrastructure includes electricity, water, telecommunication, sewage and roads and railways.

(d) **Pressure on natural resources**

With our limited natural resources and a rapidly growing people, our country might become overpopulated. This will put a great strain on food sources, water, fuel, land etc.

Sustainable developments can prevent the depletion of our natural resources.

(e) **Dependency ratio**

Dependency ratio refers to the number of economically active people in relation to the economically non-active people (0-15 years and 60 years and older).

Formula to calculate dependency ratio:

Young people (younger than 15) + old people (65 and above)

Adult group 15 – 64

In developing countries, with high birth rates, the youth is the most dependent group.

They need: education, food, shelter, entertainment and medical care.

In developed countries, the elderly are the main burden for government and the adult group.

They need: pension, old age homes, food, medical care.

A high unemployment rate amongst the adult group can also affect the dependency ratio e.g. if many people (15 – 64) are unemployed, they are also a burden for the working group or government.

(f) **Social standing**

In Namibia many people have a low income or are unemployed. It means that a majority cannot provide food, medical care and education to their children. This leads to poverty and a poorly educated society.

This might be detrimental to the economy of the country.

Activity 2



Activity



How long?

Time Required: In this activity you need at most 45 minutes to fully answer the question.

Activity: Namibia has a good railway network. Find out the distance that the railway line covers in Namibia and the recent railway extensions.



Once done with the activity, please compare your answers with mine before you proceed.



Feedback

Section 7

The spread and impact of HIV and AIDS

In this last section of Population Geography, we are going to discuss HIV and AIDS. This disease is changing the conditions of life in our communities, as well as our mortality rate and population structure.

Upon completion of this section you should be able to:



Section outcomes

- analyse the effect of the following strategies on limiting the spread and impact of HIV and AIDS in Namibia:
 - ▣ awareness campaigns
 - ▣ gender equality
 - ▣ anti-retroviral drugs
 - ▣ social services to orphans.

HIV vs AIDS

HIV- stands for human immune deficiency virus. This is the virus that attacks the immune system.

AIDS- stands for acquired immune deficiency syndrome. AIDS is the final stage of HIV infection.

NB There is no cure for AIDS

(a) Awareness campaigns

We can divide the campaigns into two groups.

Group 1- People living with HIV/Aids

- being HIV positive is not the end of the world or the end of one's life.
- People who are HIV positive suffer from stress depression and they need professional help.
- Educate the people on the complexity of the disease.
- Counseling and support is of utmost importance for these people.
- Encourage the Aids victim not to take revenge on the innocent. - You can still live a normal life if you practice safe sex. - Provide special diets.
- Churches established organizations which can deal with the problem from a religious point of view.

NB: When both persons are HIV positive and have sex without protection it can lead to re-infection or HIV 1 and HIV 2

Group 2- People living without HIV/AIDS

- Free – testing is encouraged. Know your status.
- Abstain
- Be careful
- Use a condom.
- Be faithful – Stay with one partner.
- Educate the youth on social evils that might lead to HIV/Aids.
- Sex education has been introduced in various subjects at schools.
- TV, Radio programs are in place for the latest information on HIV/AIDS.

HIV CAMPAIGNS AND ORGANISATION IN NAMIBIA



Nasoma is responsible for the distribution of a variety of condoms



New start is responsible for counseling and testing

Activity



Time Required: In this activity you need at most 45 minutes to fully answer the question.

Activity



How long?

Activity: Visit your nearest HIV campaign centre or organization and write a short summary on the functions and daily activities.

Once done with the activity, please compare your answers with mine before you proceed.



Feedback

(b) GENDER EQUALITY

Women and men have equal opportunities regarding education and employment In Namibia.



Gender equality brought a new dimension in the lives of Namibian population. Unequal treatment or opportunities have a chain reaction. When women, e.g., are denied education, it affects their children who are the future of the country.

- * Education – own job, emancipation – career – less sex workers and.
- * Awareness making – unaware of the dangers of HIV/Aids.
- * Information – Contraception's – condom women more vulnerable.

(c) Provision of anti- retroviral drugs

- These drugs are freely available in Namibia.
- The anti- retroviral therapy program provides treatment for people living with HIV/Aids was launched in 2003.
- The Ministry of Health and Social Services trained many medical Practitioners from both the public and the private sector.

OTHER MEDICINES

- * **Statins** are drugs prescribed to treat high cholesterol
- * **Mevacor** increase T cells, which fight infections in the body
- * **Acupuncture** can help to reduce the pain (very thin needles inserted into the skin at certain points on the body)

HEALTHY DIETS

- Good nutrition keeps the immune system strong.
- Process medicine
- Proteins
- Multivitamin or Minerals
- Fruit and Vegetables

THE BODY

- Take care of your bodies
- Get enough sleep
- Exercise regularly
- Oxygen and other fluids

(d) Provision of Social Services Schemes to Orphans

Due to a very high HIV prevalence rate in Namibia, a greater number of children are orphans. The group in society, that are mostly affected is the poor section of society.

Orphans are forced to stay alone without income or with families that cannot meet their needs.

Many young children, thus, leave school and are forced into child labour or crime e.g. prostitution. Their childhood will be taken away from them at a very young age.

Organizations and programs to support orphans.

1. Catholic Aids Action and USAID Namibia

They provide education for children affected by Aids. School fees are paid, uniforms bought and various other needs for schools are provided for:

2. Multi-Purpose Centre in Walvis bay orphans and other vulnerable children (ovc) are provided with a meal twice a week.
3. Bernard Nordkamp Centre in Katutura. There is a soup kitchen that provides daily meals for children.
4. Psychosocial Training for OVC (Phillipi Trust Namibia programme) It is responsible for the training of peer counselors and identifying potential young leaders for further training to provide care and support to orphans and vulnerable children.
5. AIDS law Unit of legal Assistance centre (LAC) . This project is focusing on the rights of people living with HIV/AIDS and orphans and vulnerable children.



Activity

ACTIVITY:

Make a list of any other organizations that you know that also support orphans and vulnerable children and describe their activities.



References

Reference

<http://www.geography.learnontheinternet.co.uk/topics/popn1.html>

http://en.wikipedia.org/wiki/Population_density

<http://www.geography.learnontheinternet.co.uk/topics/popn1.html>

http://wiki.answers.com/Q/What_are_the_factors_affecting_the_distribution_of_population

http://en.wikipedia.org/wiki/World_population

http://en.wikipedia.org/wiki/World_population

<http://www.otherwise.com/population/index.html>

<http://www.geography.learnontheinternet.co.uk/topics/popn1.html>

http://en.wikipedia.org/wiki/Population_pyramid

Unit summary



Summary

In this unit you learned the following:

The following factors can increase a countries fertility rate:

- Tradition (polygamy)
- Religion that forbid the use of contraception.
- High infant mortality that caused parents to have more children in the hope that they will survive.

The following can decrease the fertility rate:

- Family planning/ birth control
- Use of contraceptives
- Better medical care
- More education for women

Mortality rate

Better medical care, better hygiene and sanitation and better education can decrease the mortality rates. Wars, natural disasters and diseases like HIV and AIDS can increase the death rate.

Population Movements

Migration is the movement of people between countries or within a country. Immigration is the movement into a country. Rural area to urban areas these movements are caused by push and pull factors

Push factors are: Drought, not enough job opportunities, not enough schools, clinics and entertainment, not enough housing.

Pull factors are: Better jobs, housing, schools, entertainment, transport etc.

Rapid population growth can have positive as well as a negative effect on a countries economy. It can supply surplus of workforce to a country or it can cause overpopulation which might lead to depletion of resources.

Assessment



Assessment

1. Fig. 1 shows the population distribution and density for Namibia.

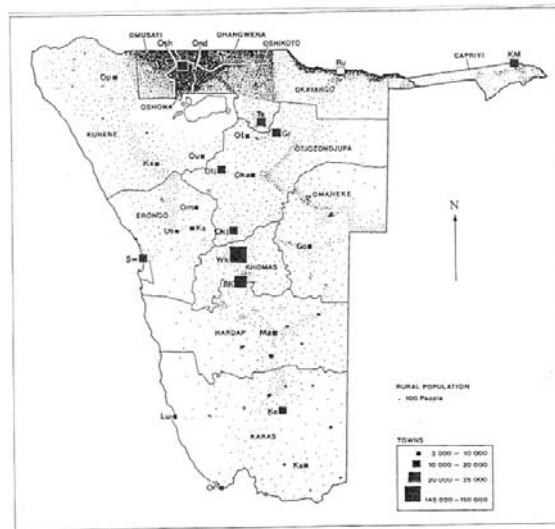

JSC 2003

Fig. 1

- Identify the region with the highest population density. [1]
- Suggest two reasons for the high density of population in the region named in (a). [2]
- Suggest two reasons for the decrease in population density towards the south and west of the country. [2]

2. Study the Demographic Transition Model (Fig. 2) shown below.

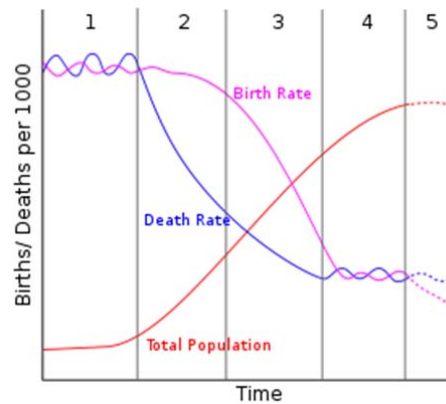

Fig. 2

- Explain why the birth and death rates are high and fluctuating in stage 1. [2x1]
- Describe how the death rate changes in stage 2. [1]
- Explain the change that takes place in the birth rate in stage 3. [2]
- Explain what will happen to growth of population in stage 5. [2]

3. Fig. 3 suggests that both “push” and “pull” factors influence people to migrate from rural to urban areas.

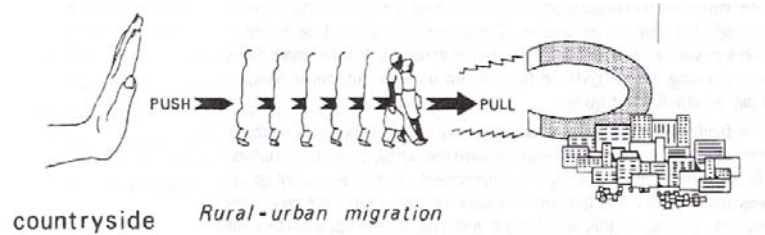
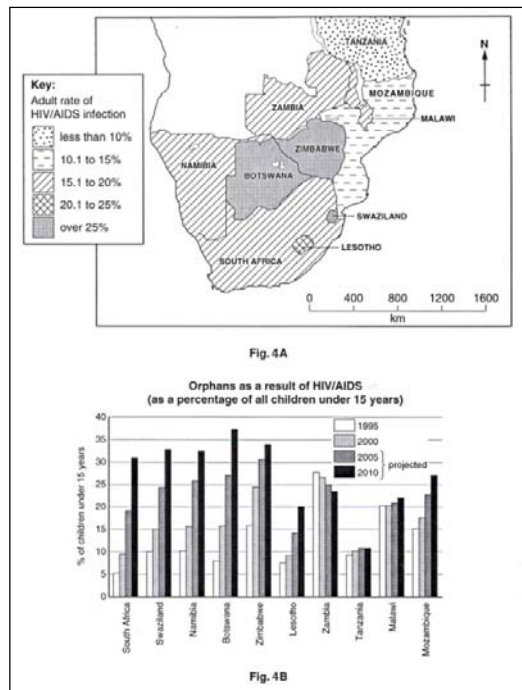

Fig. 3

- (a) Explain the term *rural-urban migration*. [1]
- (b) Suggest one “push” factor and one “pull” factor that may cause people to migrate from rural to urban areas. [2]
- (c) The growth of informal settlements in urban areas is a direct result of this type of migration.
- (i) Explain why the growth of informal settlements in cities is coupled to rural-urban migration. [2]
- (ii) Describe some of the problems experienced by people living in informal settlements. [2]

4. Figs. 4A and 4B show information about HIV/AIDS in southern Africa



*CIE 2005*

Study the information shown for Namibia in Figs. 4A and 4B.

- (a) State the adult rate of HIV/AIDS infection in the country. [1]
- (b) Describe how the high rate of HIV/AIDS infection amongst adults can impact the economy of the country. [2]
- (c) What is the projected percentage of orphans as a result of HIV/AIDS in 2010 for Namibia? [1]
- (d) Describe two problems that such orphans may experience. [2]

Assessment Feedback



Assessment

- 1 (a) Omusati and Ohangwena regions. (1)
- (b) High rainfall for farming with animals and planting, good food supply from oshanas. (2)
- (c) Decrease in rainfall which results in less vegetation and less grass for animals. Cannot plant crops and as a result less food supply. (2)
2. (a) Birth rate high because there was no family planning, for survival, no birth control, tradition and a sign of wealth.
Death rate high because of poor health facilities and high infant mortality rate. (2)
- (b) Death rate decreased because medical care improved, infant mortality rate also decreased and as a result population growth increased. (1)
- (c) Birth and death rate decreased due to advancement in medical care, education improved, family planning occurred, birth control measures were put into place and in general people started living a healthy lifestyle. (2)
- (d) Growth of population will stabilise and decrease eventually because the death rate is becoming higher than the birth rate. A negative growth in population will occur. (2)
3. (a) Movement of people from rural to urban areas. (1)
- (b) Push factors: no work, natural disasters like drought, poor medical facilities and lack of schools.
Pull factors: better jobs, better medical facilities, more schools, better work and housing, entertainment, better lifestyle. (2)
- (c) (i) People are not educated which result in no work and no housing. As a result people stay in informal settlements. (2)
- (ii) Crime, drug abuse, no schools, no services and as a result an unhealthy lifestyle. (2)
4. (a) 15.1 – 20% (1)
- (b) High HIV/AIDS infection affects a country negatively, because adults are the working group and they contribute to the economy of a country. (2)



	(c) Around 33%	(1)
	(d) More orphans means less support and that results other problems.	(1)

Unit 6

Regional Geography of Namibia

Introduction

In this unit you will learn about Namibia by looking at physical features such as drainage, vegetation and climate, and human activities such as crop and stock farming, fishing, mining, transport and tourism. You will also study economic growth in the country, as well as Namibia's role as a SADC country.

Upon completion of this unit you should be able to:



Outcomes

- *find* Namibia and its neighbouring countries on a world map;
- *identify* the most important rivers and mountains on a map of Namibia, as well as certain physiographic regions;
- *identify* on a map the most important vegetation regions;
- *explain* the factors that influence Namibia's climate;
- *explain* one crop farming, one stock farming and one mining activity in Namibia;
- *name* the types of fishing in Namibia and explain the economic importance of fishing for the country;
- *explain* one type of transport in Namibia and identify it on a map;
- *list* tourist attractions in Namibia and identify them on a map, and describe the importance of tourism for Namibia;
- *explain* how the following factors influence the economic growth of Namibia:
 - ▣ water resources
 - ▣ manufacturing industries
 - ▣ education.
- *explain* the origin, purposes and problems of SACU;

explain the origin, purposes and problems of SADC.

Now that you have studied the outcomes and know what is expected of you I want you to look at the timeframe first to see how much time is needed to complete this unit.



How long?

You will need approximately 25 hours to complete the unit.

Now that you have familiarize yourself with the time study the following terminologies first.



Terminology

tourism	Is travel for recreational, leisure or business purposes.
physiographic:	The features such as rivers, oceans, lakes and mountains.
drainage	Is the natural or artificial removal of surface and sub-surface water from an area..
Commercial farming:	Is farming to make a profit by selling the produce to a market.
Subsistence farming :	Is farming to support your immediate family without selling any of what is produced on the farm.
Pelagic fish	Fish that live near the surface of the ocean.
Demersal fish	Fish that live on or near the bottom of the sea.
Overfishing:	Is fishing more that the quota and as a result damaging the fishing population.
Upwelling	Is an oceanographic phenomenon that involves wind-driven motion of dense, cooler, and usually nutrient-rich water towards the ocean surface, replacing the warmer, usually nutrient-depleted surface water.
Open-cast	Open-pit mining, also known as open-cast mining, open-cut mining, and strip mining, refers to a method of extracting rock or minerals from the earth by their removal from an open pit or borrow.
SADC	Southern African Development Community
SACU	Southern African Customs Union

Section 1

Physical Features and Climate

In this section we will look at Namibia's neighbouring countries, as well as the most important rivers, mountains and physiographic regions in Namibia. We will also look at Namibia's climate and vegetation.

Upon completion of this section you should be able to:



Section outcomes

- *find* Namibia and its neighbouring countries on a world map;
- *identify* the most important rivers and mountains on a map of Namibia, as well as certain physiographic regions;
- *identify* on a map the most important vegetation regions;
- *explain* the factors that influence Namibia's climate.

Namibia and neighbouring countries

- Angola
- Botswana
- South Africa
- Zambia
- Zimbabwe

Neighbouring countries



Figure 6.1

Source: <http://www.worldatlas.com/webimage/countrys/africa/na.htm>

Physiographic map of Namibia



Figure 6.2

Source: <http://africa.theworldatlas.net/namibia/map.html>

Geography

Area: 823,145 sq. km. (320,827 sq. mi.); the size of Texas and Louisiana combined.

Cities: *Capital*--Windhoek (2001 census) pop. 233,529. *Other cities*--Grootfontein, Katima Mulilo, Keetmanshoop, Luderitz, Ondangwa, Oranjemund, Oshakati, Otjiwarongo, Swakopmund, Tsumeb, Walvis Bay.

Terrain: Varies from coastal desert to semiarid mountains and plateau.

Climate: Semidesert and high plateau.

Physiographic map

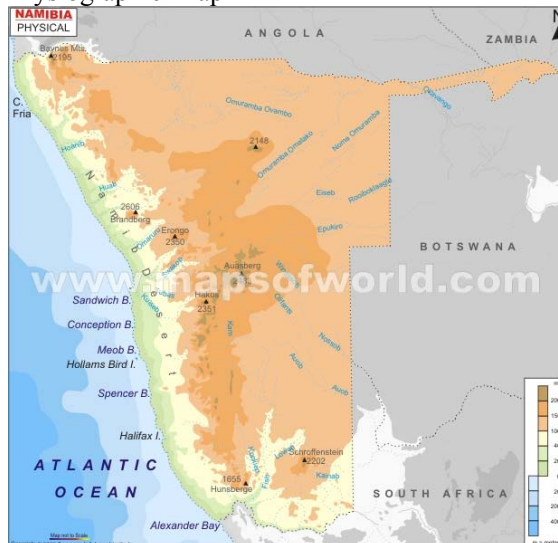

Figure 6.3

Source: <http://www.mapsofworld.com/physical-map/namibia-physical-map.html>

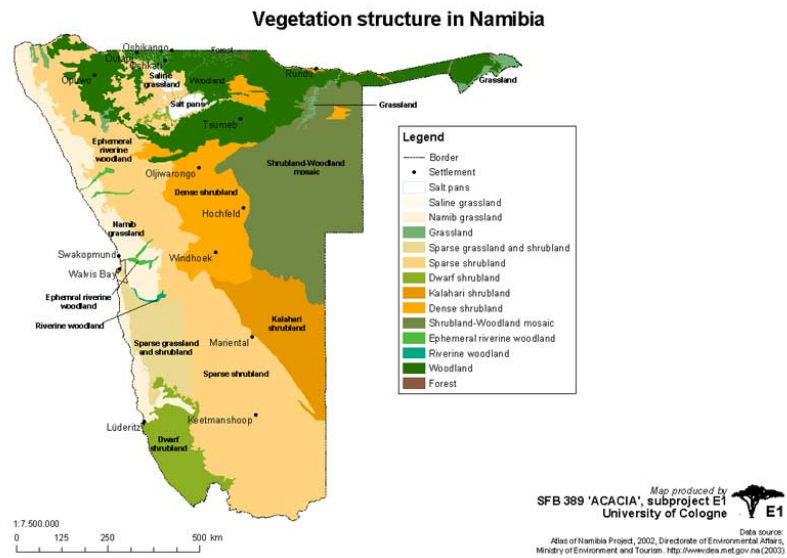

Figure 6.4
 Source: http://www.uni-koeln.de/sfb389/e/e1/download/atlas_namibia/pics/living_resources/vegetation-structure.jpg

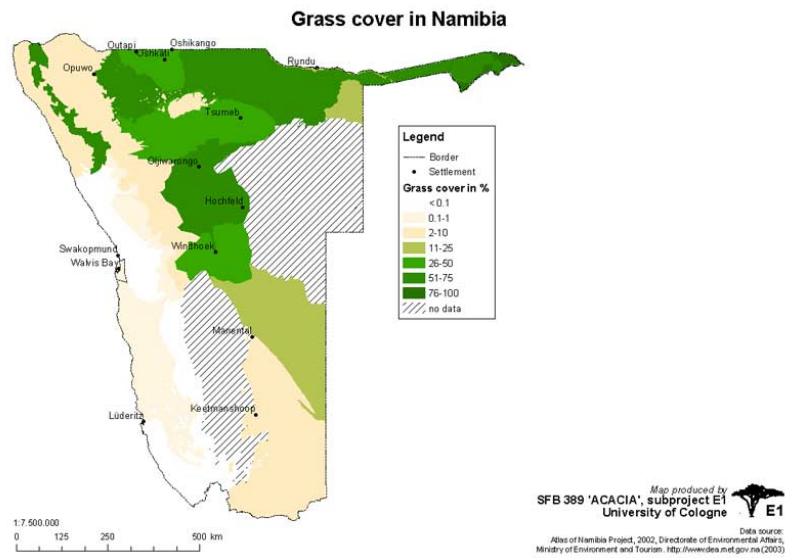

Figure 6.5
 Source: http://www.uni-koeln.de/sfb389/e/e1/download/atlas_namibia/pics/living_resources/grass-cover.jpg

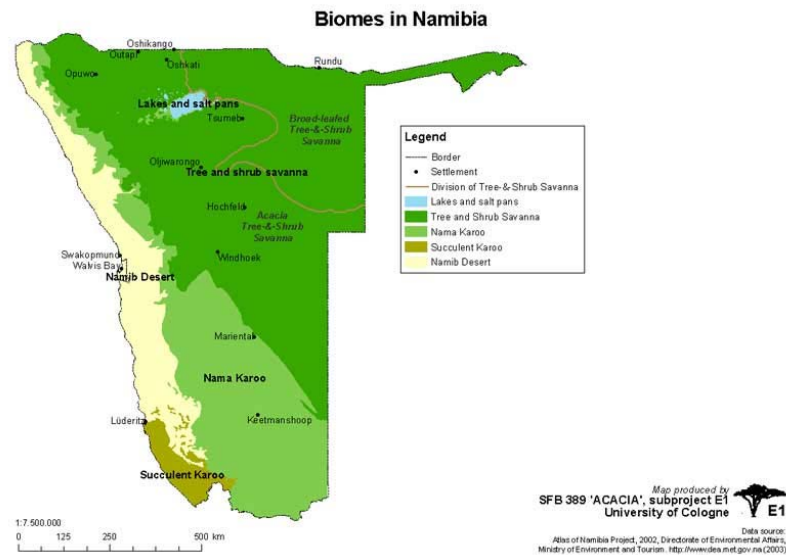

Figure 6.6

Source: http://www.uni-koeln.de/sfb389/e/e1/download/atlas_namibia/pics/living_resources/biomes.jpg

Factors influencing the climate of Namibia

1. Latitude

Does Latitude Affect Climate?

Latitude does exercise a large amount of control over any given area's climate. In fact, latitude is probably the single most important determining factor in climate. While other variables such as weather patterns and elevation have a large impact on any geographical area, latitude affects climate the most. For proof of this one only needs to compare areas of extreme northern or southern latitude, such as the North Pole or South Pole, with places that lie along the equator, such as Colombia or Somalia.

Effect of Latitude on Climate

Latitude affects climate in an area because it dictates the intensity and duration of sun exposure. As the Earth orbits the sun it also wobbles slightly on its axis. At times the Northern hemisphere is closer to the sun than the Southern hemisphere and at some times it is further from it. When an area is closer to the sun the days are longer and the sun's rays are stronger. This heats the climate. This is the reason that places experience seasonal variation in temperature. Those locations close to the equator, however, exist in a nearly constant state of summer because they always get relatively strong sunlight and have long days.

http://www.ehow.com/how-does_4586935_latitude-affect-climate.html

In geography, the **latitude** of a location on the Earth is the angular distance of that location south or north of the equator. The latitude is an angle, and is usually measured in degrees (marked with °). The equator has a latitude of 0°, the North pole has a latitude of 90° north (written 90° N or +90°), and the South pole has a latitude of 90° south (written 90° S or -90°). Together, latitude and longitude can be used as a geographic coordinate system to specify any location on the globe.

Curves of constant latitude on the Earth (running east-west) are referred to as lines of latitude. Each line of latitude is actually a circle on the Earth parallel to the equator, and for this reason lines of latitude are also known as *circles of latitude* or *parallels*. In spherical geometry, lines of latitude are examples of small circles, with the equator being a great circle.

<http://en.wikipedia.org/wiki/Latitude>

2. Pressure systems and wind

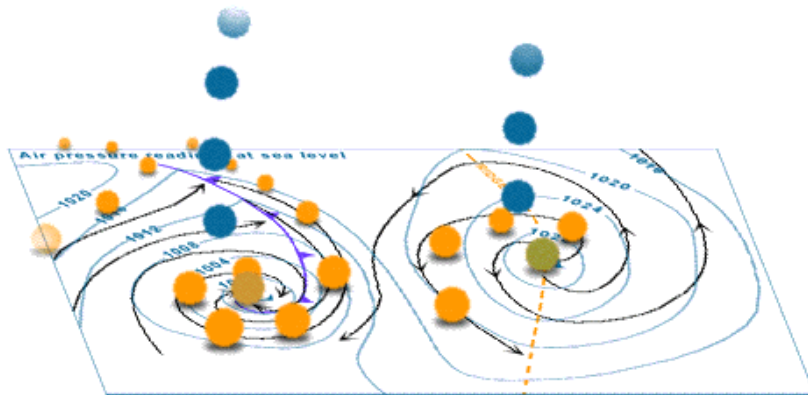

Figure 6.7

Source:

http://www.bom.gov.au/lam/Students_Teachers/pressure.shtml

Winds that blow from the sea often bring rain to the coast and dry weather to inland areas. Winds that blow to Britain from warm inland areas such as Africa will be warm and dry. Winds that blow to Britain from inland areas such as the Netherlands will be cold and dry in winter. Britain's prevailing winds come from a south westerly direction over the Atlantic. The winds are cool in the summer and mild in the winter.

3. Ocean currents

Ocean currents can increase or reduce temperatures. The diagram shows the ocean currents of the world. The main ocean current that affects the UK is the Gulf Stream.

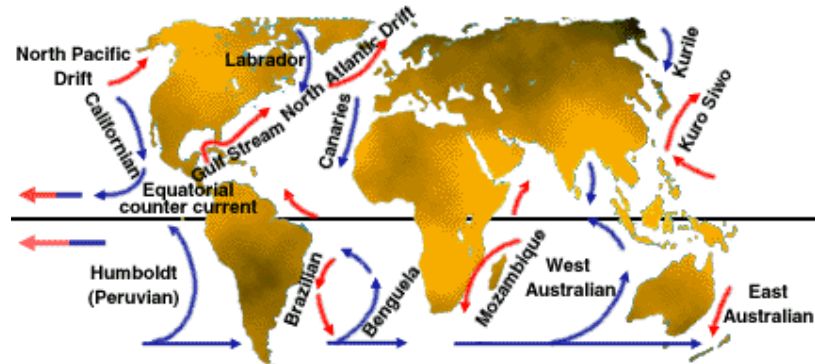

Figure 6.8

Source:

http://www.ecn.ac.uk/Education/factors_affecting_climate.htm

Can you see where the Gulf Stream is?

The Gulf Stream is a warm ocean current in the North Atlantic flowing from the Gulf of Mexico, northeast along the U.S coast, and from there to the British Isles.

The Gulf of Mexico has higher air temperatures than Britain as it's closer to the equator. This means that the air coming from the Gulf of Mexico to Britain is also warm. However, the air is also quite moist as it travels over the Atlantic Ocean. This is one reason why Britain often receives wet weather. The Gulf Stream keeps the west coast of Europe free from ice in the winter and, in the summer warmer than other places of similar latitude.

4. Distance from the sea (continentality)

The sea affects the climate of a place. Coastal areas are cooler and wetter than inland areas. Clouds form when warm air from inland areas meets cool air from the sea. The centre of continents is subject to a large range of temperatures. In the summer, temperatures can be very hot and dry as moisture from the sea evaporates before it reaches the centre of the continent.

5. Altitude

6. Relief

Climate can be affected by mountains.

Mountains receive more rainfall than low lying areas because the temperature on top of mountains is lower than the temperature at sea level. That is why you often see snow on the top of mountains all year round. The higher the place is above sea level the colder it will be. This happens because as altitude increases, air becomes thinner and is less able to absorb and retain heat.



Activity

Time Required: In this activity you need at most 45 minutes to fully answer the question.

Activity



ADD ACTIVITY PLEASE

How long?

Once done with the activity, please compare your answers with mine before you proceed.



Feedback

Section 2

Human activities in Namibia

In this section we are going to study the farming, mining and fishing activities in Namibia.

Upon completion of this section you should be able to:

- explain one crop farming, one stock farming and one mining activity in Namibia;
- name the types of fishing in Namibia and explain the economic importance of fishing for the country;
- explain one type of transport in Namibia and identify it on a map;
- list tourist attractions in Namibia and identify them on a map;
- describe the importance of tourism for Namibia.



Section outcomes

Agriculture

Although Namibian agriculture--excluding fishing--contributed between 5% and 6% of Namibia's GDP for the past 5 years, a large percentage of the Namibian population depends on agricultural activities for livelihood, mostly in the subsistence sector. Animal products, live animals, and crop



exports constituted roughly 10.7% of total Namibian exports. The government encourages local sourcing of agriculture products. Retailers of fruits, vegetables, and other crop products must purchase 27.5% of their stock from local farmers.

In the largely white-dominated commercial sector, agriculture consists primarily of livestock ranching. Cattle raising is predominant in the central and northern regions, while karakul sheep and goat farming are concentrated in the more arid southern regions. Subsistence farming is mainly confined to the "communal lands" of the country's populous north, where roaming cattle herds are prevalent and the main crops are millet, sorghum, corn, and peanuts. Table grapes, grown mostly along the Orange River in the country's arid south, are becoming an increasingly important commercial crop and a significant employer of seasonal labor.

The government's land reform policy is shaped by two key pieces of legislation: the Agricultural (Commercial) Land Reform Act 6 of 1995 and the Communal Land Reform Act 5 of 2002. The government remains committed to a "willing seller, willing buyer" approach to land reform and to providing just compensation as directed by the Namibian constitution. As the government addresses the vital land and range management questions, water use issues and availability are considered.

Fishing

The clean, cold South Atlantic waters off the coast of Namibia are home to some of the richest fishing grounds in the world, with the potential for sustainable yields of up to 1.5 million metric tons per year. Commercial fishing and fish processing is one of the significant sectors of the Namibian economy in terms of employment, export earnings, and contribution to GDP. In 2009, fishing contributed almost 3.6% of GDP, while on-shore processing of fish products contributed another 1.4%. The Namibian Government has actively pursued value-addition policies aimed at increasing on-shore processing of fish products.

The main species found in abundance off Namibia are pilchards (sardines), anchovy, hake, and horse mackerel. There also are smaller but significant quantities of sole, squid, deep-sea crab, rock lobster, and tuna. However, at the time of independence, fish stocks had fallen to dangerously low levels due to the lack of protection and conservation of the fisheries and the overexploitation of these resources. This trend appears to have been halted and reversed since independence, as the Namibian Government is now pursuing a conservative resource management policy along with an aggressive fisheries enforcement campaign. Namibia is a signatory to the Convention on Conservation and Management of Fisheries Resources in the South-East Atlantic (Seafo Convention). The country is also part of the Benguela Current Large Marine Ecosystem (BCLME) program, which is designed to help the Governments of Namibia, Angola, and South Africa manage their shared marine resources in an integrated and sustainable way.

Manufacturing and Infrastructure

In 2009, Namibia's manufacturing sector (including meat and fish processing) contributed about 13.5% of GDP. Namibian manufacturing

has historically been inhibited by a small domestic market, dependence on imported goods, limited supply of local capital, widely dispersed population, small skilled labor force and high relative wage rates, and subsidized competition from South Africa.

Walvis Bay has a well-developed, deepwater port, considered by many one of the best in Western Africa, and Namibia's fishing infrastructure is most heavily concentrated there. The Namibian Government expects Walvis Bay to become an important commercial gateway to the Southern African region. However, government officials acknowledge that many segments of Namibia's more than 2,300 kilometers of rail infrastructure require urgent rehabilitation. Upgrades to Namibia's rail infrastructure are considered a critical element in the government's plan to expand the port of Walvis Bay.

Namibia also boasts modern civil aviation facilities and an extensive, well-maintained land transportation network. Construction continues to expand two major arteries--the Trans-Capri and Trans-Kalahari Highways--which will further open up the region's access to Walvis Bay.

Tourism

Tourism is a rapidly growing sector of the Namibian economy and a significant generator of employment. It is the third-largest source of foreign exchange after mining and fisheries. Although the majority of Namibia's international visitors originate in the region, other international travelers are increasingly attracted by the country's unique mix of political stability, cultural diversity, and geographic beauty. Tourism in Namibia has had a positive impact on resource conservation and rural development. As of 2007, there were 50 communal conservancies established across the country, resulting in enhanced land management while providing tens of thousands of rural Namibians with much needed income.

Labor

While most Namibians are economically active in one form or another, the bulk of this activity is in the informal sector, primarily subsistence agriculture. In the formal economy, the official estimate of unemployment is 51.2% of the work force. In March 2011, the government introduced a 3-year budget that contains significant (30%) additional spending over prior years with a focus on public works and infrastructure to stimulate economic growth and generate employment opportunities, primarily for Namibia's unskilled workers. A large number of Namibians seeking jobs in the formal sector are held back due to a lack of necessary skills or training. The government is aggressively pursuing education reform to address this problem.

There are two main trade union federations in Namibia representing workers: the National Union of Namibian Workers (NUNW), which is affiliated with the ruling SWAPO party, and the Trade Union Congress of Namibia (TUCNA), which is not affiliated with any party. A new labor law went into effect in November 2008. The new law prohibited employers from using "labor hire" (third-party hiring of temporary or



contract workers); however, the Supreme Court declared this provision unconstitutional in December 2009.

Mining and Energy

As was the case for many countries, Namibia's extractive industries, particularly the diamond industry, experienced a significant decline due to the recent global economic downturn, although uranium was an exception. Mining contributed approximately 10% of GDP in 2009. While Namibia recovered over 2 million carats of diamonds in 2008, it mined only 929,000 carats in 2009, a 58% drop in production. Diamond mining rebounded in 2010, with close to 1.5 million carats recovered. Namibia is the world's fourth-largest producer of uranium oxide, representing approximately 10% of global uranium production. Namibia has two operational uranium mines. Two or three new uranium mines may open over the next 5 years. Other important mineral resources are zinc, copper, lead, gold, fluorspar, and salt. The country also is a source of natural stones such as granite and marble. Semiprecious stones are mined on a smaller scale.

During the pre-independence period, large areas of Namibia, including offshore, were leased for oil prospecting. Natural gas was discovered in 1974 in the Kudu Field off the mouth of the Orange River. The field is thought to contain reserves of over 1.3 trillion cubic feet. In 2009, the government announced changes to the ownership structure of the Kudu project. Tullow Oil Plc, which had owned 70% of the Kudu gas field, saw its stake drop to 31%. Japanese firm Itochu Corporation, which owned 20% in the project, now owns 15%. The Namibian Government through state petroleum firm NAMCOR has partnered with the Russian firm Gazprom to take a 54% stake in Kudu. NAMCOR had previously held a 10% interest. Plans are also underway to build the country's first combined cycle power station near Oranjemund. With power shortages facing the Southern African region, the government has stated its commitment to develop the Kudu gas field. However, supply of electricity in the short to medium term remains a challenge.

Namibia has a well-developed legislative framework governing the upstream and downstream oil business. Currently there are eight companies exploring for oil and gas.

Activity



Activity

Time Required: In this activity you need at most 45 minutes to fully answer the question.



How long?

ADD ACTIVITY PLEASE

Once done with the activity, please compare your answers with mine before you proceed.



Feedback

Section 3

Economic growth in Namibia

In this section we will look briefly at three factors that can influence Namibia's economic growth, such as water resources, industry and education.

Upon completion of this section you should be able to:



Section outcomes

- explain how the following factors influence the economic growth of Namibia:
 - ▣ water resources
 - ▣ manufacturing industries
 - ▣ education.

Economic growth in Namibia

Factors that influence Namibia's economic growth

(a) Water resources:

Rainfall in Namibia is very low and unreliable. Underground is also limited. High temperature cause high evaporation which leads to the scarcity of water.

Effects of water scarcity on the economy

- Low agricultural outputs.
- High water tariffs for mines and industries.
- Restrictions on domestic use of water.
- Over use of perennial sources of water.
- Groundwater is over-utilised.

(b) Manufacturing

Namibia has a very small manufacturing industry. Most of the manufactured commodities needs to be imported. Most manufactured products in Namibia are very expensive due to high cost of production. A lack of local skilled labour in the manufacturing is another constraint.

(c) Education

There's a lack of skilled labourers in Namibia. A high failure rate and drop outs contributed mainly to the high rate of unemployment.



Man on the side of the road

Educational institutions

Not enough schools contributed to overcrowded classrooms.

Shortage of qualified teachers in certain fields has a negative effect on human resource development.

The University of Namibia, Polytechnic colleges of education provided tertiary education. To supplement the full-time education sector, there are institutions like NEAC, MAMCOL and TUCSIN that provide open and distance learning.

ACTIVITY: Discuss in groups how education could contribute to economic growth.



AUGUSTINEUM SECONDARY SCHOOL (oldest school in Namibia)
It mainly offered technical subjects

ECONOMY

The Namibian economy has a modern market sector, which produces most of the country's wealth, and a traditional subsistence sector. Namibia's gross domestic product (GDP) per capita is relatively high among developing countries but obscures one of the most unequal income distributions on the African continent. Although the majority of the population depends on subsistence agriculture and herding, Namibia has more than 200,000 skilled workers, as well as a small, well-trained professional and managerial class.

The country's sophisticated formal economy is based on capital-intensive industry and farming. However, Namibia's economy is heavily dependent on the earnings generated from primary commodity exports in a few vital sectors, including minerals, livestock, and fish. Furthermore, the Namibian economy remains integrated with the economy of South Africa, as the bulk of Namibia's imports originate there.

Since independence, the Namibian Government has pursued free-market economic principles designed to promote commercial development and job creation to bring disadvantaged Namibians into the economic mainstream. To facilitate this goal, the government has actively courted donor assistance and foreign investment. The liberal Foreign Investment Act of 1990 provides for freedom from nationalization, freedom to remit capital and profits, currency convertibility, and a process for settling disputes equitably.

Namibia is part of the Common Monetary Area (CMA) comprising



Lesotho, Swaziland, and South Africa. Both the South African rand and the Namibian dollar are legal tender in Namibia, but the Namibian dollar is not accepted in South Africa. As a result of the CMA agreement, the scope for independent monetary policy in Namibia is limited. The Bank of Namibia regularly follows actions taken by the South African central bank.

Given its small domestic market but favorable location and a superb transport and communications base, Namibia is a leading advocate of regional economic integration. In addition to its membership in the Southern African Development Community (SADC), Namibia presently belongs to the Southern African Customs Union (SACU) with South Africa, Botswana, Lesotho, and Swaziland. Within SACU, no tariffs exist on goods produced in and moving among the member states. In July 2008, SACU signed a Trade, Investment and Development Cooperation Agreement (TIDCA) with the United States. SACU also has plans to negotiate free trade agreements with China, India, Kenya, and Nigeria. The SACU Secretariat is located in Windhoek.

Over 80% of Namibia's imports originate in South Africa, and many Namibian exports are destined for the South African market or transit that country. Outside of South Africa, the EU (primarily the U.K.) is the chief market for Namibian exports. Namibia's exports consist mainly of diamonds and other minerals, fish products, beef and meat products, grapes and light manufactures.

Namibia is seeking to diversify its trading relationships away from its heavy dependence on South African goods and services. Europe has become a leading market for Namibian fish and meat, while mining concerns in Namibia have purchased heavy equipment and machinery from Germany, Italy, the United Kingdom, the United States, and Canada. Namibia is an eligible country under the African Growth and Opportunity Act (AGOA), but has had limited success with exports under this program.

In 1993, Namibia became a General Agreement on Tariffs and Trade (GATT) signatory, and the Minister of Trade and Industry represented Namibia at the Marrakech signing of the Uruguay Round Agreement in April 1994. Namibia has been a member of the World Trade Organization since its creation in 1995 and is a strong proponent of the Doha Development Agenda announced at the Fourth Ministerial Conference in Doha, Qatar, in November 2001. Namibia also is a member of the International Monetary Fund and the World Bank. In December 2007 Namibia initialed an interim Economic Partnership Agreement (EPA) with the European Union, but has not yet signed the interim agreement. The EPA provides duty- and limited quota-free access to European markets for Namibian exports, thereby continuing many of the expiring trade benefits from the Cotonou Agreement. Negotiations continue over the new EPA.

State-owned enterprises operate in many key sectors of the Namibian economy. The government has stakes (often 100% ownership) in companies in the following sectors: telecommunications (fixed and

mobile voice and data services), energy, water, transport (air, rail, and road), postal services, fishing, mining, and tourism.



Activity

Activity

Time Required: In this activity you need at most 45 minutes to fully answer the question.

ADD ACTIVITY PLEASE

Once done with the activity, please compare your answers with mine before you proceed.

Section 4

Regional unions

This section deals briefly with two regional unions that play an important role in Namibia's economy: SACU and SADC.

Upon completion of this section you should be able to:



Section outcomes

- explain the origin, purposes and problems of SACU;
- explain the origin, purposes and problems of SADC.

Origin

The Southern African Customs Union (SACU) dates back to June 29 1910, when South Africa, Basutoland, Swaziland and Bechuanaland signed at Potchefstroom. Only Britain and South Africa were involved in the 1910 negotiations². This Agreement lasted until the British



Protectorates received Independence in the mid 1960s. It was then renegotiated with the apartheid government, culminating in the 1969 Agreement.

The 1969 Agreement has attracted widespread attention from economists and political commentators since it effectively ensured that throughout the sanctions period three frontline states (Botswana, Lesotho and Swaziland) continued to depend on South Africa for their imports and to a lesser extent their exports. The agreement also included a revenue sharing formula for the division of customs and excise revenue collected in the union and the BLS received a significant proportion of their government revenue through this formula.

When Namibia became independent in 1990 it became a SACU member in its own right. However, by then, it was evident that the 1969 Agreement had almost run its course.

REGIONAL UNIONS

Southern African Customs Union (SACU)

The member states are: Botswana; Lesotho; Namibia; South Africa and Swaziland.

SPACE FOR SACU MAP

REASONS FOR THE ESTABLISHMENT OF SACU

*The union offers a common external and a revenue-sharing formula by which the commonly collected revenue is distributed among the members of the union.

*no internal customs duties to be paid between the member states

SOUTHERN AFRICAN DEVELOPMENT COMMUNITY (SADC)

The SADC was formed in 1992. It has replaced the Southern African Development Co-ordinating Conference which had been formed in 1980.

MAP OF SADC

The member states are: Angola, Botswana, Democratic Republic of Congo; (DRC) Lesotho; Malawi; Mozambique; Namibia; Mauritius; Madagascar; South Africa; Swaziland; Tanzania; Zimbabwe and Zambia.

Official languages of the SADC are English, Portuguese and French

Aims of SADC

-to promote economic growth

- to promote and defend peace and security
- to strengthen economic and cultural cooperation between member states
- to develop common political values, systems and institutions
- to promote food production

Each member country is responsible for the coordination of a specific activity. Namibia is responsible for Marine Fisheries and Resources.

Problems of SADC

- high population growth in member states
- droughts lower production in the agricultural sector
- political and economic instability in member states
- high cost of imported goods
- low prices for raw materials that are exported
- not enough foreign investments
- not enough skilled human resources in own countries

Achievements of SADC

- peaceful co-operation among members
- strong support from foreign investors
- improved climate for investment between regions and members

ACTIVITY: The SADC TRIBUNAL was a milestone in the history of the SADC .What is the main function of the tribunal.



SADC Tribunal in Windhoek



Activity

Activity

Time Required: In this activity you need at most 45 minutes to fully answer the question.

ADD ACTIVITY PLEASE

Currently SADC has a membership of 15 Member States, namely; [Angola](#), [Botswana](#), [Democratic Republic of Congo \(DRC\)](#), [Lesotho](#), [Madagascar](#), [Malawi](#), [Mauritius](#), [Mozambique](#), [Namibia](#), [Seychelles](#), [South Africa](#), [Swaziland](#), [United Republic of Tanzania](#), [Zambia](#) and [Zimbabwe](#).

Once done with the activity, please compare your answers with mine before you proceed.

Unit summary



Summary

In this unit you learned Namibia is situated between 17°S and 29°S, and 12°E and 21°E. Namibia's borders are surrounded by: the Atlantic Ocean in the west, Angola and Zambia in the north, Botswana and Zimbabwe to the east and South Africa to the south-east.

The physiographic regions of the country include the Namib Desert or coastal plain to the west along the Atlantic ocean, the escarpment that separates the desert from the central plateau, the central plateau in the centre of the country that stretches from north to south and the Kalahari basin in the east. The central plateau forms a watershed that causes some rivers to drain towards the west, while others drain towards the east. Only the rivers that form the northern and southern borders of Namibia are perennial. All the other rivers are ephemeral (non-perennial). There are only two natural lakes in Namibia. Perennial rivers have water all year round. Non-perennial or ephemeral rivers only flow during the rainy season and they can either be periodic or episodic.

The vegetation is determined by the rainfall that decreases in occurrence from north-east to south-west. The highest rainfall occurs in the Caprivi area (about 700 mm per year) and the lowest is in the Namib Desert (less than 50 mm per year). Very little vegetation occurs along the coast in the desert, but further to the east and north-east the vegetation becomes more lush, with grass and trees. Vegetation in the south is mainly short grass and small shrubs.

Namibia's climate is influenced by the following factors: latitude, altitude, pressure systems, proximity (closeness) to the sea and the cold Benguela current.

Crop farming in Namibia consists mainly of maize and omahango and is practised in areas where the rainfall is higher. Omahango is the main crop in the northern parts of the country on communal farms. Maize is grown on commercial farms. The stock farming is mainly of beef cattle and sheep. Cattle farming occurs in the eastern and central parts of the country, as well as on the Cuvelai floodplains. Sheep farming occurs mainly in the southern parts of the country, where these animals are well adapted to the drier and harsher conditions. Karakul sheep are bred for their pelts, meat and wool.

Namibia has very rich fishing fields. Demersal (deep sea) fish, like hake, sole and kingklip, are caught through the process of trawling. Pelagic (surface) fish, like pilchard and anchovy, are caught through purse-seine fishing. Line fishing is used to catch snoek. During the rainy season fresh-water fishing is very important in the oshanas of the far northern parts of Namibia. The fishing industry is very important to the economy of Namibia, because it creates jobs, provides food for the population and also contributes to foreign exchange.

Mining is the backbone of the Namibian economy. The two most important minerals mined in Namibia are uranium and diamonds.



Uranium is mined at Rössing near Swakopmund, in the world's largest open-cast uranium mine. Diamonds are mined at the coast near Oranjemund, also in open-pit mines.

Namibia has a very well-developed transport network of roads, railroads, airfields and also two harbours. Two main highways, the Trans-Kalahari and the Trans-Caprivi Highways, link Namibia to its neighbouring countries. These two highways are also used by the neighbouring landlocked countries to get access to the harbour of Walvis Bay for exporting and importing.

Tourism plays an important part in the economy of the country. It creates jobs and it brings in foreign currency. Namibia has beautiful landscapes, wildlife and wide open spaces.

The following factors play an important role in the economy of Namibia: water resources, manufacturing and education.

Namibia is a member state of both SACU and SADC. Namibia's sectorial responsibility in SADC is marine fisheries and resources. There are 14 member countries and the headquarters are in Gaborone in Botswana.

References

- | | |
|-----------|---|
| Reference | http://en.wikipedia.org/wiki/Latitude
http://www.ecn.ac.uk/Education/factors_affecting_climate.htm
http://www.ehow.com/how-does_4586935_latitude-affect-climate.html |
|-----------|---|

Assessment



Assessment

1. Fig. 1 shows some of the physical features of Namibia.

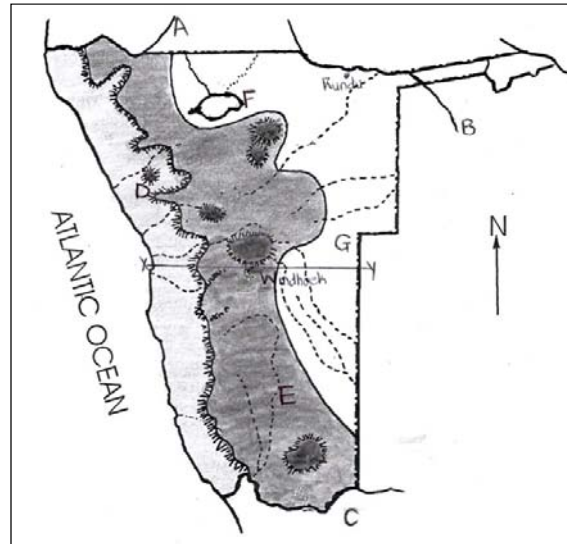

Adapted from JSC 2004

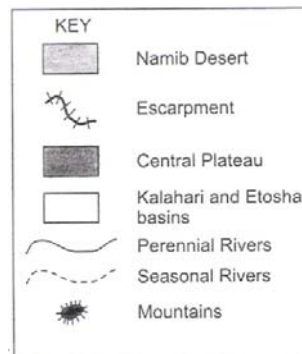

Fig. 1

- (a) Identify the following physical features:
1. the perennial rivers A and B [2]
 2. the neighbouring country C [1]
 3. the mountain D [1]
 4. the physiographic region E [1]
 5. the physical feature F [1]
 6. the natural vegetation found at G [1]
- (b) Explain why Rundu may experience higher temperatures than

Windhoek.

[1]

2. Answer the following questions on Mining in Namibia.

- (a) Describe the economic importance of uranium to the town of Arandis. [2]
- (b) Explain what uranium is used for. [2]
- (c) Describe the location of the main diamond mining area in Namibia. [1]
- (d) Describe how diamonds are recovered from the sea floor offshore. [1]

3. Figs. 3A and 3B show two fishing methods used in commercial fishing.

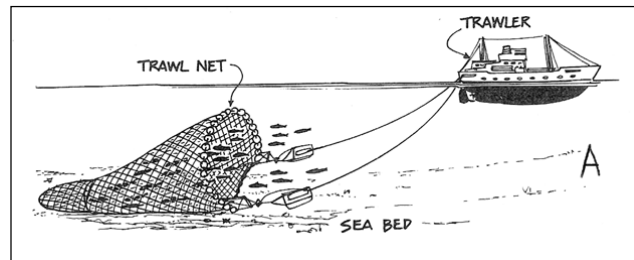

Fig. 3A

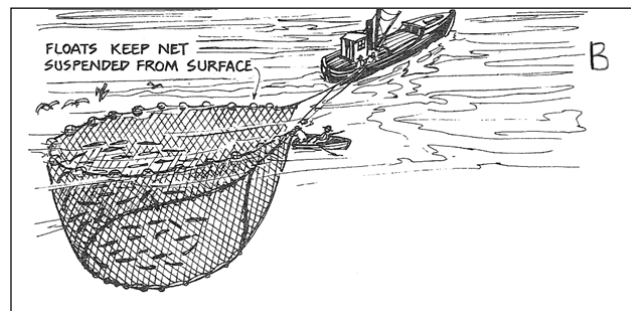

Fig. 3B

- (a) Distinguish between demersal and pelagic fish. [2]
- (b) Identify the methods of fishing used in A and B. [2]
- (c) Describe two ways in which the fishing industry contribute to the economy of the country. [2]

4. Fig. 4 shows some very important tourist attractions and national parks in Namibia.

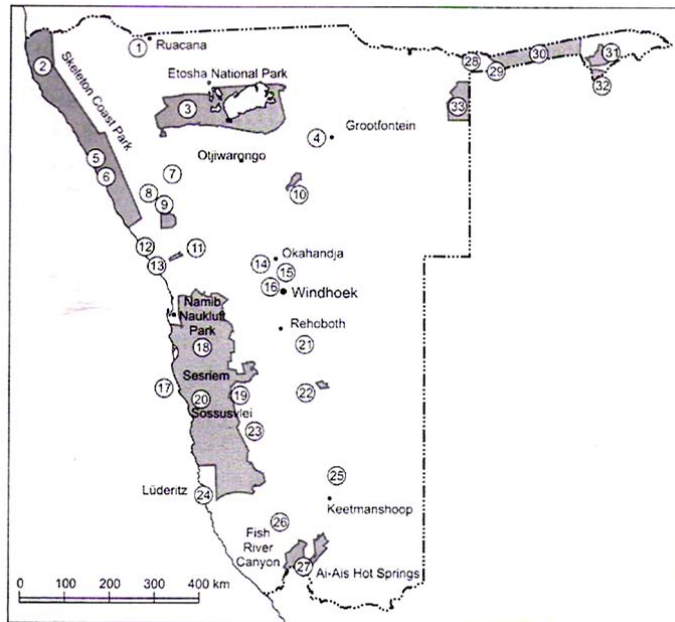

Fig. 4

- (a) Identify the following features shown on Fig. 9
- | | |
|-----------|-----|
| number 10 | [1] |
| number 25 | [1] |
- (b) Describe two ways in which the tourism industry in Namibia contributes to our Gross Domestic Product. [2]
- (c) Explain why the tourism sector is also important for the natural environment in Namibia. [1]

Assessment Feedback



Assessment

- 1 (a) 1. A – Kunene river
B – Okavango river
2. Republic of South Africa
3. Brandberg
4. Central Plateau
5. Etosha Basin
6. shrub / camelthorn savanna [7x1]
- (b) Rundu is closer to the equator than Windhoek. [1]
- 2 (a)-Rössing supplies 6% of the world's demand for uranium.
-The mine employs the majority of people living in Arandis.
-Rössing is involved in social developments , e.g. developing of sport facilities in the town. (any 1) [1]
- (b)-As fuel for nuclear power stations
-To produce nuclear weapons [2]
- (c) The main diamond mining area stretches over 100km northwards from the mouth of the Orange River along the Namibian coast. [1]
- (d) Diamonds are recovered from the sea floor offshore by specially equipped mining ships and a bucket-wheel dredge. [1]
3. (a) demersal – fish that live near the bottom of the sea-bed / ocean. [1]
- pelagic – fish that live near the surface of the ocean. [1]
- (b) A – trawling [1]
B – purse-seine fishing [1]
- (c) -foreign exchange / exports
-increase of the GDP of the country
-income
-jobs / multiplier effect
-development of infrastructure

	-foreign or international investment	(any 2)	[2]
4. (a)	10 – Waterberg Plateau		
	25 – Quiver Tree Forest		[2]
(b)	-Tourism brings valuable income and foreign currency		
	-It creates many jobs.		[2]
(c)	Tourism helps to ensure that the natural environment is protected and looked after.		[1]
			[25]

Assignment 3



Assignment

Question 1

(a) Study Fig. 1, a map of the world which shows areas of high and low population density.

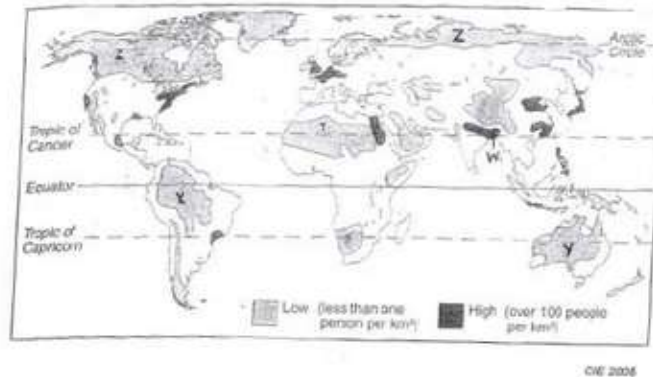

(i) Distinguish between population distribution and population density. [2]

(ii) Identify the types of hostile environments labelled X and Y on the map. [2]

X _____

Y _____

(iii) Explain why areas Z on the map are sparsely populated.

[2]

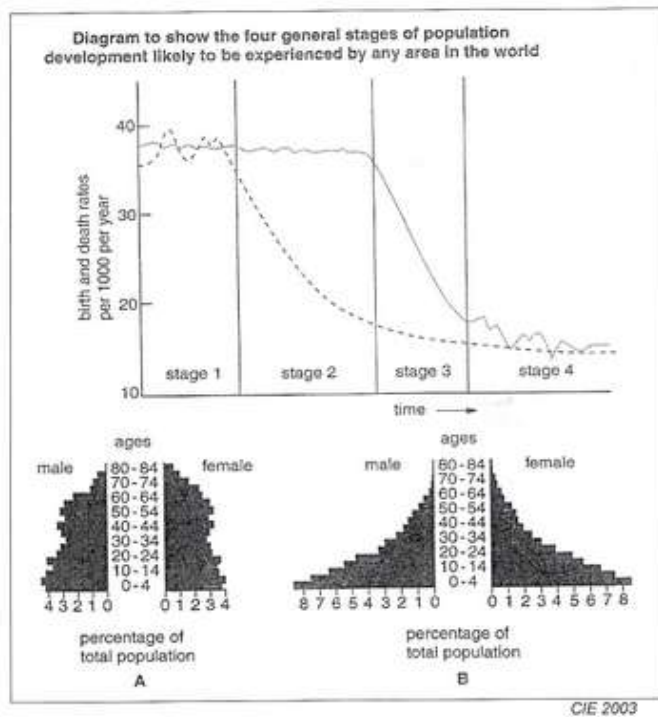

Fig. 3

(i) On the graph, indicate which line represents birth rate and which line represents death rate. [2]

(ii) On the graph, shade all the areas where natural increase occurs. [3]

(iii) What is happening to the death rate in Stage 2? [1]

(iv) Suggest reasons for the change in death rate as described in (iii). [2]

(v) What is happening to the birth rate in Stage 3? [1]

(vi) Suggest reasons for the change in birth rate as described in (v). [2]

(vii) Study the population pyramids A and B shown in Fig.3.

In which stage of development 1, 2, 3 or 4 would each population pyramid be found? [2]

Pyramid A is found in stage _____ Pyramid B is found in stage _____

(viii) Give reasons why you chose the stage for each pyramid. [2]

Pyramid

A _____

Pyramid

B _____

Question 3

Figs. 4A and 4B show information about HIV/AIDS in southern Africa.

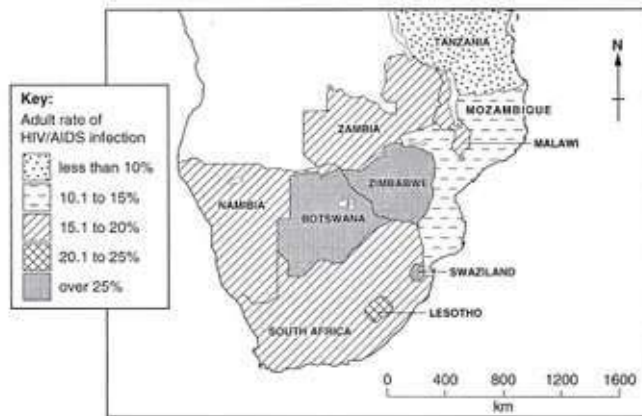

Fig.4A

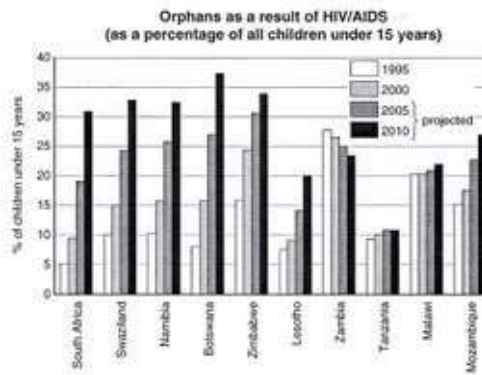

Fig.4B

(a) Use Fig. 4A to name two countries where over 25% of the adult population are infected with HIV/AIDS. [2]

(b) Use the information in Fig. 4B to:

(i) State the percentage of children who will be orphans as a result of HIV/AIDS in Lesotho in 2010. [1]

(ii) Name a country where the expected percentage of orphans will be decreasing by 2010. [1]

 (iii) Name the country with the highest expected number of orphans as a result of HIV/AIDS. [1]

 (c) Study the information shown for Namibia in Figs. 4A and 4B.

(i) State the adult rate of HIV/AIDS infection in the country. [1]

 (ii) Describe how the high rate of HIV/AIDS infection amongst adults can impact the economy of the country. [2]

 (iii) Describe some of the strategies that are being used to try and reduce the spread of HIV/AIDS in Namibia. [3]

 (iv) What is the projected percentage of orphans as a result of HIV/AIDS in 2010 for Namibia? [1]

 (v) Describe two problems that such orphans may experience. [2]

Question 4

(a) Fig. 5 suggests that both ‘push’ and ‘pull’ factors influence people to migrate from rural to urban areas.



(i) Explain the term rural-urban migration. [1]

 (ii) Suggest one ‘push’ factor and one ‘pull’ factor that may cause people to migrate from rural to urban areas. [2]

(iii) The growth of informal settlements in urban areas is a direct result of this type of migration.

1. Explain why the growth of informal settlements in cities is coupled to rural-urban migration. [2]

2. Describe some of the problems experienced by people living in informal settlements. [2]

Total Marks Section A: [50]

Section B – Regional Geography of Namibia

Question 5

(a) Fig. 6 shows some of the physical features of Namibia.

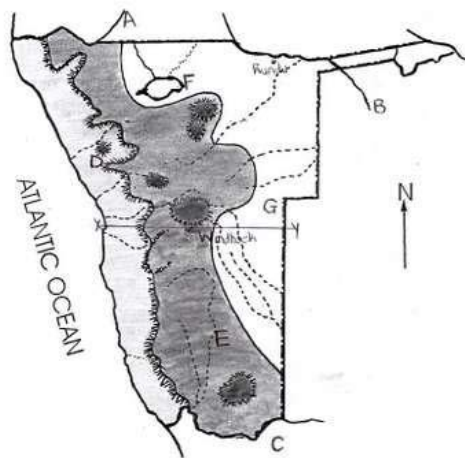

Adapted from JSC 2004



Fig. 6

(i) Identify the following physical features:

1. the perennial rivers A and B [2]
 A _____ B _____
2. the neighbouring country C [1]

3. the mountain D [1]

4. the physiographic region E [1]

5. the physical feature F [1]

6. the natural vegetation found at G [1]

(ii) Explain why Rundu may experience higher temperatures than Windhoek. [1]

(iii) Complete the cross-section of the country from X to Y by adding the following labels on your diagram:

plateau coastal plain escarpment Kalahari basin [4]

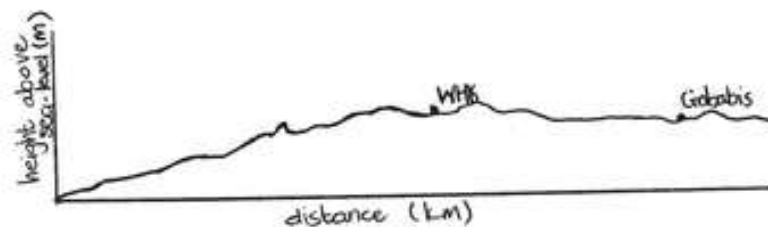

(iv) Use your cross-section drawn in (ii) to explain

1. Why temperatures in Windhoek may be lower than temperatures in Gobabis. [1]

2. Why Swakopmund receives high amounts of fog. [1]

Question 6

Fig. 7 shows some agriculture, mining and fishing activities in Namibia.

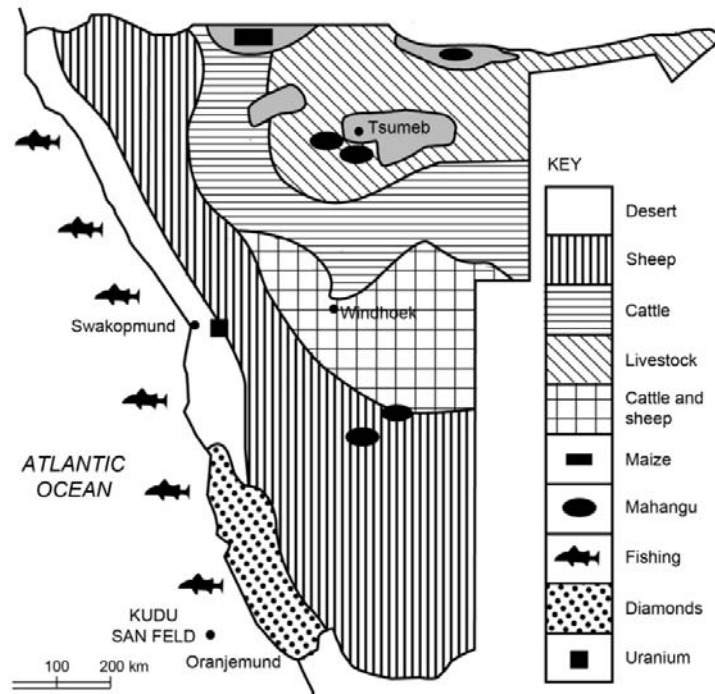

Fig. 7 Namcol JSC

(a) (i) Distinguish between commercial and communal farming. [2]
commercial farming

communal farming

(ii) Identify the crop that is mainly grown along the Okavango and Kunene rivers. [1]

(iii) Explain why the crop named in (ii) is also suitable to be grown in dry areas. [1]

(iv) Identify the crop that is mainly grown in the Otavi Highlands. [1]

(v) Explain why the maize triangle area is suitable for growing the crop

named in (iv).

[1]

(vi) Name two regions in Namibia where cattle are reared commercially.
[2]

(vii) Explain why commercial cattle farming is important to the economy of the country.
[2]

(viii) The majority of sheep farms are located in the southern parts of the country.

Explain why.

[1]

(b) Fig. 7 shows two important mining towns in the country.

(i) Describe the economic importance of uranium to the town of Arandis.
[2]

(ii) Explain what uranium is used for.

[1]

(iii) Describe the location of the main diamond mining area in Namibia.
[1]

(iv) Describe how diamonds are recovered from the sea floor offshore.
[1]

Question 7

(a) Figs. 8A and 8B show two fishing methods used in commercial fishing.

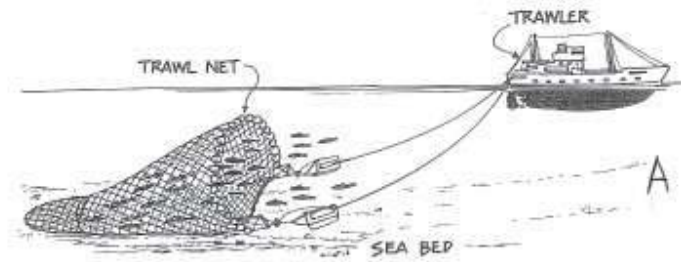

Fig. 8A



Fig. 8B

(i) Distinguish between demersal and pelagic fish.

demersal [1]

Pelagic [1]

(ii) Identify the methods of fishing used in A and B. [2]

A _____ B _____

(iii) Describe two ways in which the fishing industry contribute to the economy of the country. [2]

(iv) Describe two measurements that the Government has taken to protect the fishing industry in Namibia. [2]

(b) Fig. 9 shows some very important tourist attractions and national parks in Namibia.

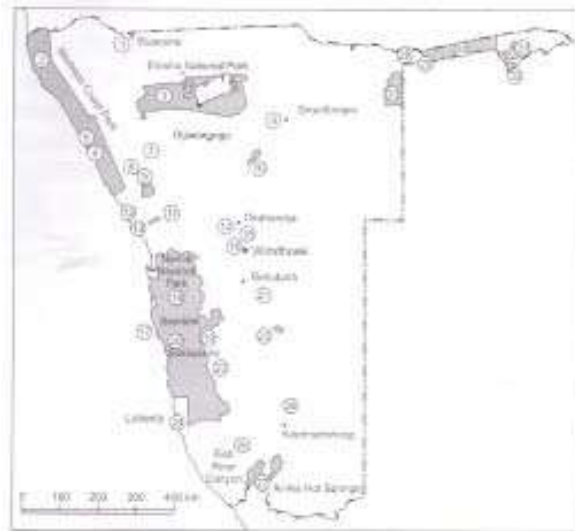

Fig. 9 Namcol JSC

(i) Identify the following features shown on Fig. 9

number 10 _____ [1]

number 25 _____ [1]

(ii) Describe two ways in which the tourism industry in Namibia contributes to our Gross Domestic Product. [2]

(iii) Explain why the tourism sector is also important for the natural environment in Namibia. [1]

Question 8

Fig. 10 shows the SADC member states.



Namcol JSC

Fig. 10

(a) What does the acronym SADC stand for? [1]

(b) In which city are the headquarters of SADC situated? [1]

(c) Describe one of the aims of SADC. [1]

(d) Describe one problem experienced by SADC. [1]

(e) Identify two SADC member states which also form part of the Southern African Customs Union. [1]

(f) Which important highway links Namibia with Botswana, Zambia and Zimbabwe? [1]

(g) Give reason why it is so important for Botswana, Zambia and Zimbabwe to be linked via road to Namibia? [1]

Total Marks for Section B: [50]

Total Marks for Assignment 3: [100]

Assignment 3 Feedback



Assignment

Section A – Population Geography

Question 1

(a) (i) Population distribution:

Where people live in relation to each other / The way in which people are spread out over the earth's surface. [1]

Population density:

The number of people per km² [1]

(ii) X – tropical rainforest [1]

Y – deserts / Sahara desert [1]

(iii) Z is sparsely populated because:

-too cold for people to live in

-frozen soils

-growing season very short. [2]

(iv) W- India and Bangladesh [1]

(v) W is densely populated because:

-low-lying areas and flat

-fertile soil

-lots of rain (any 2) [2]

All of these are ideal conditions for farming.

(b) (i) Oshana region [1]

(ii) Oshana is densely populated because:

-high annual rainfall – good water supply

-flooding (efundja) of oshanas during raining season provides fish for food.

-fertile soil (any 2) [2]

(iii) -rainfall decreases towards the southern and western parts

-vast areas of barren soil not suitable for agriculture

-harsh temperatures (any 2) [2]

Question 2

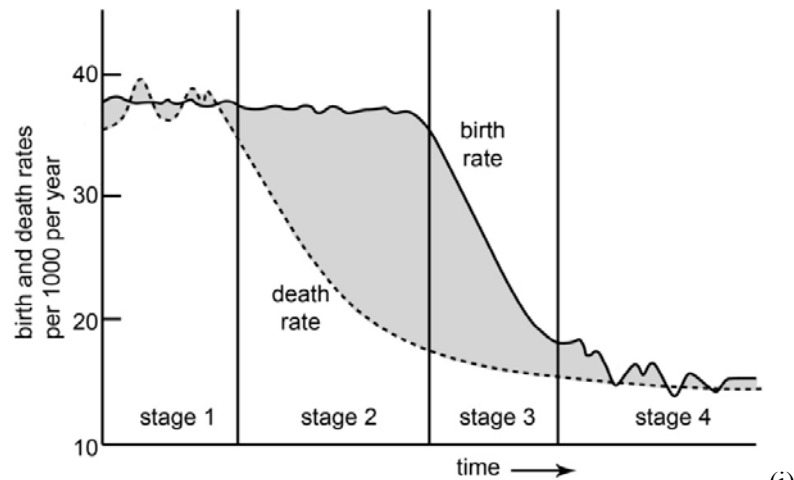

correct indication of birth rate and death rate

[2x1]

(ii) correct shading: 1 mark for stage 1

1 mark for stages 2+3

1 mark for stage 4

[3x1]

(iii) Death rate decreases / declines (rapidly).

[1]

(iv) Reasons for decreasing death rate:

- better medical care – new drugs, vaccinations, doctors, hospitals
- provision of clean water
- reliable food supply
- good hygiene and sanitation
- lower population densities
- better transport to move food and medical supplies
- overall decrease in IMR

-immunisation against major diseases (any 2)

[2]

(v) Birth rate decreases / declines (rapidly).

[1]

(vi) Reasons for decreasing birth rate:

- family planning encourages the use of contraceptives and sterilisation
- fewer babies die, so less pressure on parents to have many children
- better technology creates smaller need for labourers
- people want material possessions and therefore have fewer children
- children are expensive
- parents have pensions so they do not rely on children for security
- women's rights
- women want their own careers so they have less time to look after children

- women marry at a later stage which gives them fewer childbearing years
- reduced poverty
- improved health (any 2) [2]
- (vii) A – stage 4
- B – stage 2 [2]
- (viii) A -developed country
- decreasing birth rate
- low death rate
- high life expectancy
- many old age people (any 1) [1]
- B -developing country
- high birth rate
- high death rate
- low life expectancy
- very few old age people (any 1) [1]

Question 3

- (a) Botswana / Zimbabwe / Swaziland (any 2) [2]
- (b) (i) 20% [1]
- (ii) Zambia [1]
- (iii) Botswana [1]
- (c) (i) 15.1 – 20% [1]
- (ii) Economy will decrease / negative growth / GDP will show negative growth
- fewer workers
- more money used for aids prevention, fewer for other developments
- less food produced
- reduces productive capacity of people (people cannot work)
- discourages development (of e.g. tourism industry)
- discourages foreign investment
- need to import skilled labour abroad which could be expensive (any 2) [2]
- (iii) -awareness campaigns (through posters, tv-adverts etc.)
- sex education in schools
- gender equality
- use of antibiotics / medicine



-use of ARVs	
-reduction in prices of ARVs	
-support for orphans (any 3)	[3]
(iv) 32% or 33%	[1]
(v) -they are left with no adult care when both parents die	
-many times families cannot provide adequately for orphans	
-children must take on the duties of parents who died	
-no income, food, no money to pay for school, etc.	
-they have no one to talk to about their problems / no support	
-lost childhood (cannot play like other children) (any 2)	[2]
Question 4	
(a) (i) The movement of people from rural to urban areas.	[1]
(ii) Push factors:	
-harsh climates, drought	
-unproductive land / infertile soil	
-natural disasters (earthquakes, floods, hurricanes, etc.)	
-no jobs available / poverty	
-no schools, hospitals	
-crop failure	
-mechanisation reduces need for workers	
-no entertainment (any 1)	[1]
Pull factors	
-mild climates	
-no natural disasters	
-more jobs available	
-better schools and hospitals	
-better housing and living conditions (any 1)	[1]
NB: push factors must be negative, pull factors positive.	
no marks for repetition of answers.	
(iii) 1. -migrants do not always find work	
-they cannot afford housing in urban areas	
-they build shacks with any kind of material that they can find.	[2]
2. -unemployment / poverty	
-houses are built of very poor materials and offer no resistance against heavy wind and rain	

- poor roads
- crime
- no piped water and electricity
- fire hazards due to open fires and candles
- far from schools and hospitals
- no drains or sewage
- unhygienic conditions due to open sewage
- no rubbish removal
- overcrowded living conditions causing fast spread of disease (any 2)

[2]

Total Marks for Section A [50]

Section B – Regional Geography

Question 5

(a) (i) 1. A – Kunene river

B – Okavango river

2. Republic of South Africa

3. Brandberg

4. Central Plateau

5. Etosha Basin

6. shrub / camelthorn savanna

[7x1]

(ii) Rundu is closer to the equator than Windhoek.

[1]

(iii)

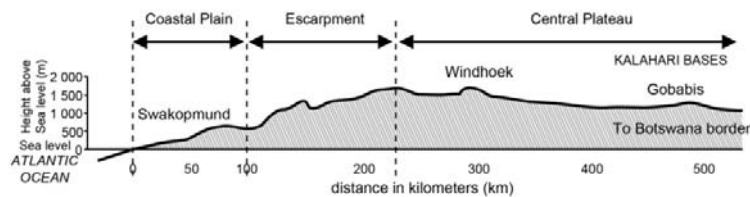

[4x1]

(iv) 1. Windhoek is situated at a higher altitude than Gobabis.

[1]

2. The cold Benguela current causes fog along the coast /

Situated near the ocean /sea.

[1]

Question 6

(a) (i) Commercial farming:

-The farmer sells his products for a profit.

[1]

Communal farming:



- The farmer produces only enough for own consumption. [1]
- (ii) omahangu / millet [1]
- (iii) It has strong roots that can penetrate deep into the soil
(for underground water.)
- Can withstand periods of drought
- Can grow in less fertile soil. (any 1) [1]
- (iv) maize [1]
- (v) -This area has plentiful underground water that can be used for
irrigation
- High rainfall area (any 1) [1]
- (vi) Otjozondjupa / Omaheke / Khomas (any 2) [2]
- (vii) -Namibian beef is exported and brings in foreign exchange.
- It provides employment to many Namibians. [2]
- (viii) Sheep can adapt to the hot and dry conditions in the south of
Namibia. [1]
- (b) (i) -Rossing supplies 6% of the world's demand for uranium.
- The mine employs the majority of people living in Arandis.
- Rossing is involved in social developments , e.g. developing of sport
facilities in the town. (any 2) [2]
- (ii) -As fuel for nuclear power stations
- To produce nuclear weapons (any 1) [1]
- (iii) The main diamond mining area stretches over 100km northwards
from the mouth of the Orange River along the Namibian coast. [1]
- (iv) Diamonds are recovered from the sea floor offshore by
specially equipped mining ships and a bucket-wheel dredge. [1]

Question 7

- (a) (i) demersal – fish that live near the bottom of the sea-bed / ocean.
[1]
- pelagic – fish that live near the surface of the ocean. [1]
- (ii) A – trawling [1]
- B – purse-seine fishing [1]
- (iii) -foreign exchange / exports
- increase of the GDP of the country
- income
- jobs / multiplier effect
- development of infrastructure

- foreign or international investment (any 2) [2]
- (iv) -air and sea patrols / controls illegal fishing
- people need licenses and permission
- fisheries inspectors to monitor
- government declared exclusive economic zone (EEZ)
- fishing quotas or number of fish (TAC)
- fishing seasons and closing areas
- size of fish / mesh size of fishing nets (any 2) [2]
- (b) (i) 10 – Waterberg Plateau Park
25 – Quiver Tree Forest [2]
- (ii) -Tourism brings valuable income and foreign currency
- It creates many jobs.
- Develops infrastructure such as lodges and restaurants. (any 2) [2]
- (iii) -Tourism helps to ensure that the natural environment is protected and looked after.
- Local people protect fauna & flora by creating conservancies. (any 1) [1]

Question 8

- (a) Southern African Development Community. [1]
- (b) Gaborone [1]
- (c) Aims:
 - to develop common political values, systems, institutions
 - to promote and defend peace and security
 - to promote the economic independences of member states
 - to strengthen economic and cultural cooperation between members
 - to promote food production (any 1) [1]
- (d) Problems:
 - political and economic instability in member states
 - droughts can lower agricultural and livestock production
 - low world prices for raw materials that are exported
 - high cost of imported goods
 - high population growth rate in member states
 - not enough foreign investment
 - not enough skilled human resources in own countries (any 1) [1]
- (e) South Africa / Namibia / Botswana / Lesotho / Swaziland (any 2)

[1]

NB: 2 for 1 mark

(f) Trans-Caprivi highway

[1]

(g) These landlocked countries gain access to the harbour in Walvis Bay (for exporting and importing.)

[1]

Total Marks for Section B [50]

Total marks for Assignment 3: [100]

Sample Question Papers



Assessment

Sample Question Paper.

Paper1

QUESTION 1: CLIMATOLOGY

(a) The diagram in Figure 1 below shows the Stevenson Screen. Answer the following questions.

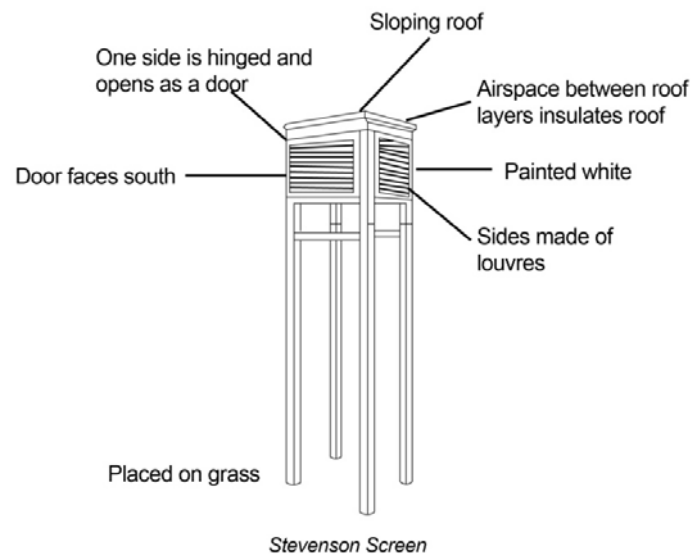

Figure 1

(i) What is the function of the Stevenson Screen? (1)

(ii) Why:

(aa) does the door open to the south? (1)

(bb) is it mounted 1,2m above the surface? (1)

(iii) Study the diagram in Figure 2 below and answer the following questions.

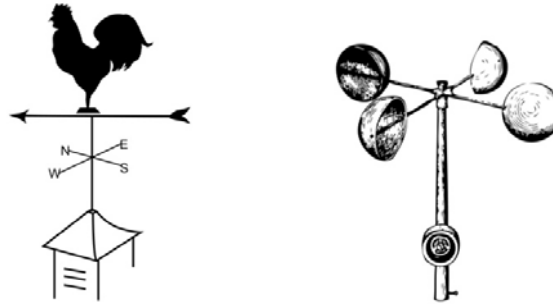

Figure 2

(aa) What is the name of the weather instrument in figure 2A? (1)

(1)

(bb) What is the function of the anemometer in figure 2B? (1)

/5/

(b) Study Figure 3 below of a simple pressure system and answer the question:

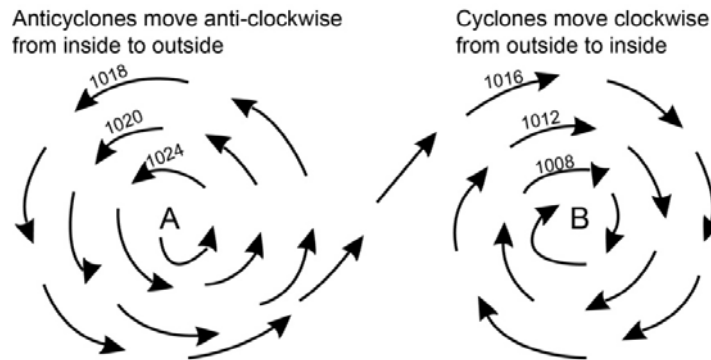

Figure 3

(i) What do we call the lines that connect places with equal air pressure? (1)

(1)

(ii) Identify the type of pressure at A. (1)

(iii) Which of the two cells (A or B), is more likely to cause rain? Motivate your answer. (3)

(3)

/5/

(c) Study the diagrams, Figure 4A and B below and answer the questions.

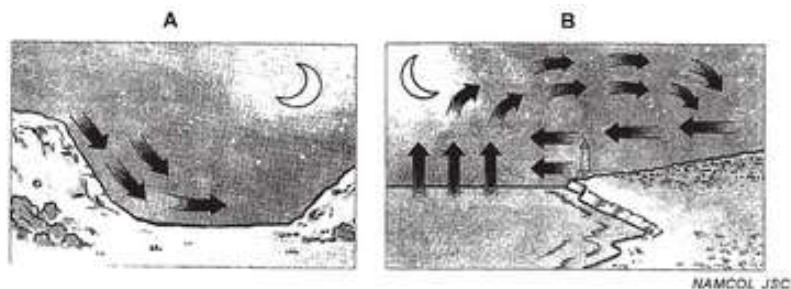

Figure 4

- (i) Identify the breeze in Figure 4A. (1)
- (ii) Use Figure 4B to explain why a low pressure develops at the sea and a high pressure on the land during the night. (4)

/5/

[15]

QUESTION 2: ECOLOGY

(a) Give the correct concept for each of the following phrases.

(i) The study of the relation of plants and living creatures with each other and with their surroundings. (1)

(ii) Gradual increase of average temperatures over the world. (1)

(iii) When an area is becoming more and more like a desert. (1)

(iv) The poisoning and dirtying of the atmosphere. (1)

(v) The replacement of grassland by shrubs and bushes. (1)

/5/

(b) Study Photograph A below and answer the following questions.



Rory Douglas et al. *Geography in Context*

Photograph A

- (i) Identify the type of pollution. (1)
- (ii) Name one cause of this type of pollution. (1)
- (iii) Suggest three possible solutions for this type of pollution. (3)

/5/

(c) Study Photograph B below which shows an example of the effects of bush encroachment.



Geography of Namibia

Photograph B

- (i) What is meant by the term “bush encroachment”? (1)
 - (ii) Identify two causes of bush encroachment. (2)
 - (iii) What can be done to prevent bush encroachment? (2)
- /5/
[15]

QUESTION 3: GEOMORPHOLOGY

(a) Figure 5 shows the different tectonic plates. Answer the following questions.

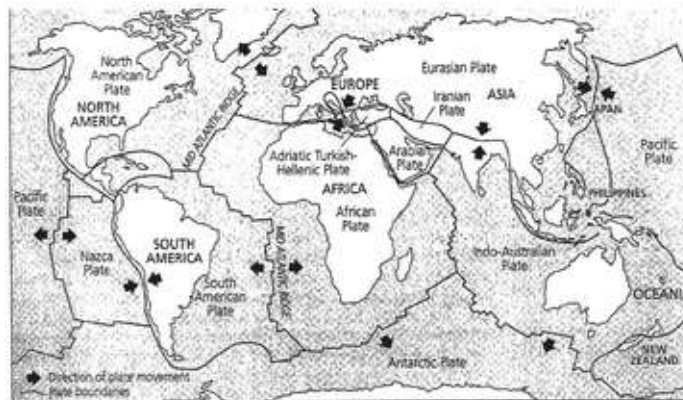

NSSC - Geography NAMCOL

Figure 5

- (i) What is a plate? (1)
- (ii) What type of plate boundary do we find between the
 - (aa) South American Plate and the African Plate?
 - (bb) Eurasian Plate and the Indo-Australian Plate? (2)
- (iii) What landform is found at the plate boundary mentioned in (ii) (aa)? (1)
- (iv) What happens in a subduction zone? (1)

/5/

(b) The diagram below, Figure 6, shows an illustration of an earthquake. Study the diagram and answer the questions.

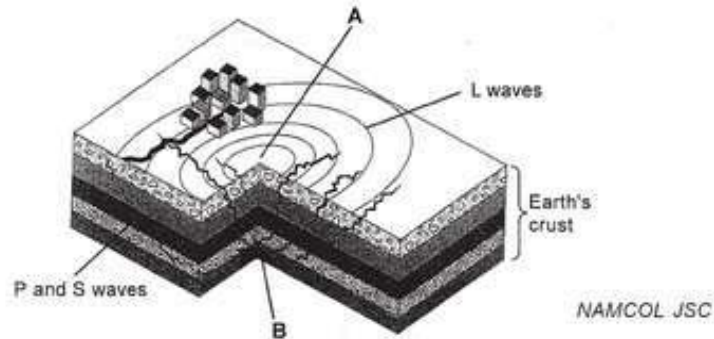

Figure 6

- (i) What is an earthquake? (1)
 (ii) Which one of the letters A or B represents the epicentre? (1)
 (iii) Read the extract below and answer the following questions.

On 26 December 2004, one of the most destructive tsunamis of modern times followed after a massive earthquake occurred in the sea near the Indonesian island

of Sumatra. A few hours after the earthquake, a series of enormous tsunamis destroyed everything in their way along the coasts of 11 countries in South East Asia and East Africa. Approximately 250 000 people were killed and millions of people were left homeless.

- (aa) Explain briefly how tsunamis are caused. (1)
 (bb) From the extract only, name two effects of tsunamis. (2)

/5/

(c) The diagram in Figure 7 shows a type of physical/mechanical weathering.

Study the diagram and answer the questions.

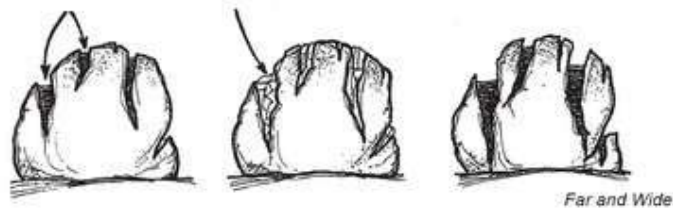

Figure 7

- (i) What is weathering? (1)
 (ii) Name two agents of erosion. (2)
 (ii) Use the diagram and explain the process of frost shattering/freeze-

thaw. (2)

/5/

[15]

QUESTION 4: POPULATION GEOGRAPHY

(a) Study the map of Namibia in Figure 8 and answer the questions.

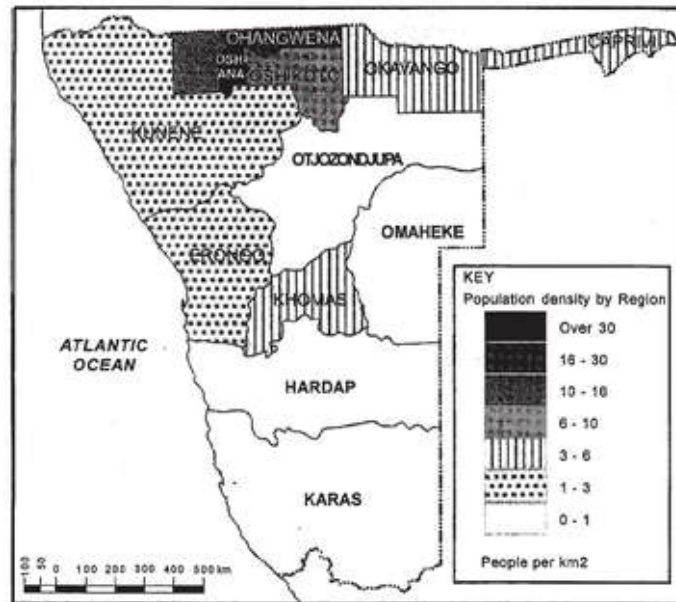

Namibia: Population densities, NAMCOL JSC

Figure 8

(i) What is meant by population density? (1)

(ii) Name the most densely populated region in Namibia.

What is the density of that region? (2)

(iii) What does “sparsely populated” mean? (1)

(iv) Give one reason for the low population density in the Karas Region.

(1)

/5/

(b) Study Figure 9, showing world population, and answer the following questions.

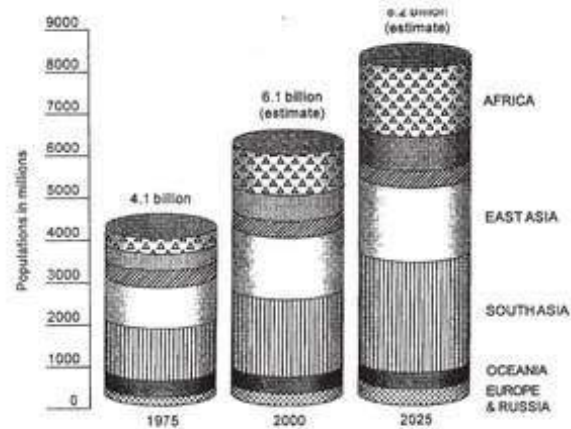

Rory Douglas et al. *Geography in Context*

Figure 9

- (i) What is the estimate for the population of the world in the year 2025?
(1)
- (ii) Which area shows the greatest estimated increase in population from 2000 – 2025?
(1)
- (iii) By how many is the world population estimated to increase from 1975 – 2025?
(1)
- (iv) Suggest two problems that areas with a high population growth might experience in future.
(2)

/5/

- (c) Read the extract below, which refers to HIV and AIDS in Namibia.

The overall rate of infection in Namibia has increased from 4% in 1992 to 22% in 2000. Of all people with HIV, 25% are in the age group 25-29. In 1992 less than 2% of deaths were caused by AIDS. This number rose to 28% in 2000. One out of every four deaths during 2000 was due to AIDS. The majority of deaths occur among people between the ages of 25 and 45. of those who died of HIV and AIDS between 1995 and 1999, 54% were males and 46% were females. A recent survey by UNAIDS

- (ii) Which age group, according to the extract, was most infected by HIV and AIDS in the year 2000?
(1)
- (iii) By what percentage did the infection rate increase from 1992 to 2000?
(1)
- (iv) Suggest two strategies to reduce the spread and impact of HIV and AIDS in Namibia.
(2)

/5/

[15]

QUESTION 5

(a) Study Figure 10, a map of part of an urban settlement.

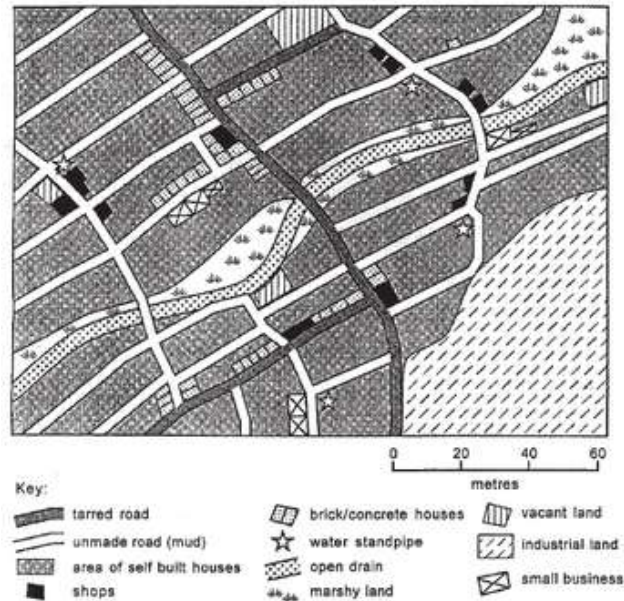

Figure 10

(i) Give two pieces of map evidence which suggest that this area is part of a squatter settlement. (2)

(ii) What problems might be experienced in rural areas due to rural-urban migration? (3)

(b) (i) Define the term fertility. (1)

(ii) Explain the effect of a high infant mortality rate on the birth rate. (2)

(iii) Suggest two reasons for the low life expectancy in developing countries. (2)

/5/

/10/

QUESTION 6: REGIONAL GEOGRAPHY

(a) Figure 11 shows the physiographic regions of Namibia and neighbouring countries.

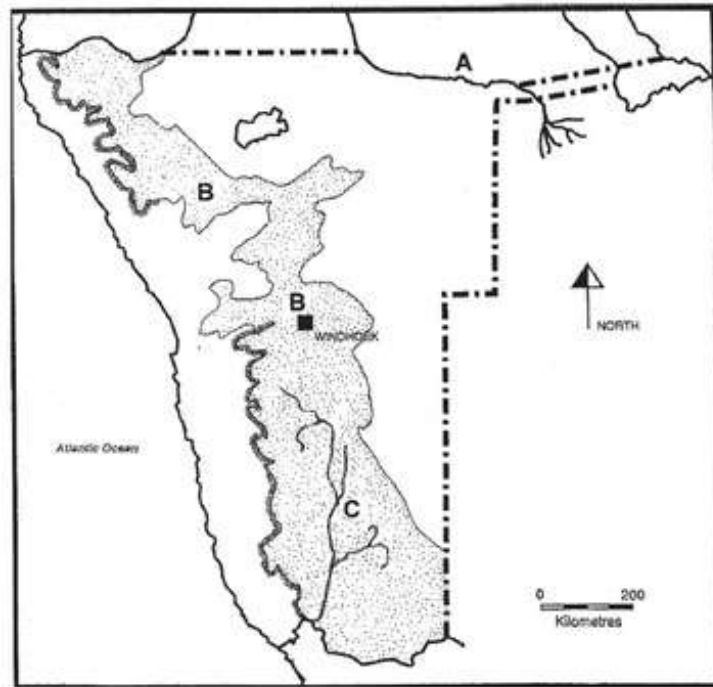

Figure 11

- (i) Which neighbouring country is indicated by the letter A? (1)
- (ii) Identify the physiographic region at B. (1)
- (iii) Name the River at C. (1)
- (iv) Which well-known natural tourist attraction is formed by this river? (1)
- (v) Suggest a reason why the Kunene River is most suitable for the generation of hydro-electrical power. (1)

/5/

(b) Figure 12A and B show different methods of fishing.

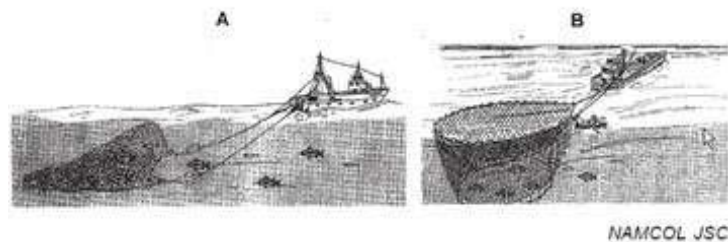

Figure 12

- (i) Identify the methods of fishing in A and B. (2)
- (ii) Which of the methods (A or B) is used to catch pelagic fish? (1)
- (iii) Describe the economic importance of fishing in Namibia. (2)

/5/

[10]

QUESTION 7

(a) Study the map of Southern Africa in Figure 13 which shows the transport network of Namibia.

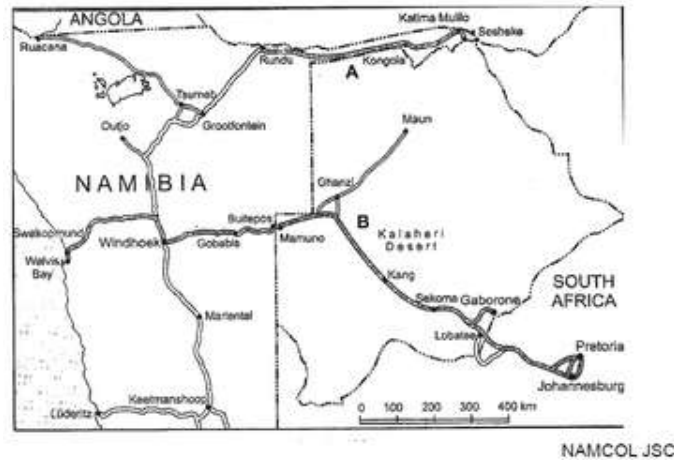

Figure 13

- (i) Identify the highways at A and B. (2)
- (ii) Name two countries that are linked by the highway at A. (2)
- (iii) Write down the name of the type of transport that you have studied and give:
- (aa) one advantage (1)
- (bb) one disadvantage (1)
- /6/

(b) Study the map of Namibia in Figure 14 below, which shows the minimum and maximum temperatures for Namibia, and answer the following questions.

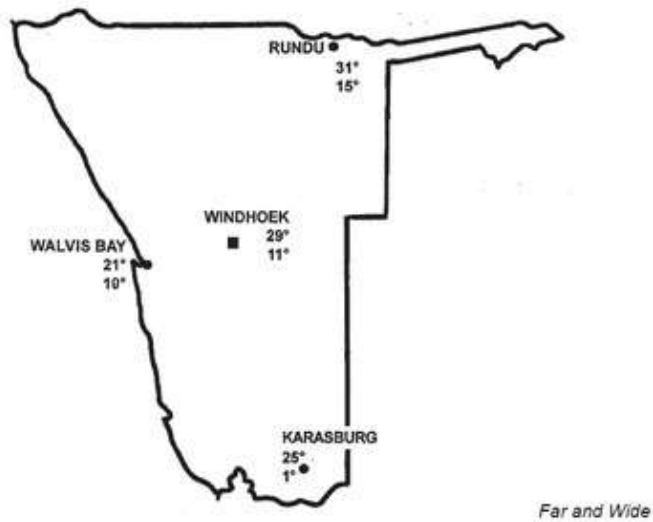

Figure 14

- (i) Which town, Karasburg or Rundu, has the highest average temperature? (1)
- (ii) Suggest a reason for the difference in temperatures in (i). (1)
- (iii) Which town has the smallest temperature range? (1)
- (iv) Give a reason for your answer in (iii). (1)
- /4/
[10]

PAPER 2

QUESTION 1

Study the topographical map of Arandis below and answer the following questions.

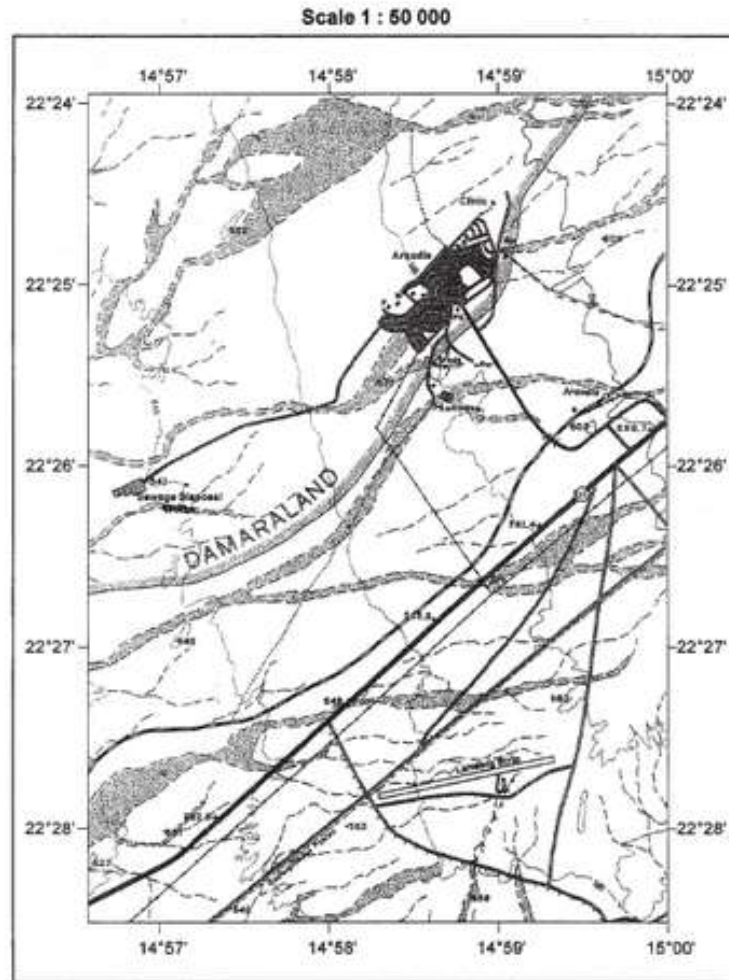

Figure 1

- (a) Identify the type of scale. (1)
 - (b) Convert the abovementioned scale to a word scale. (1)
 - (c) In which direction would you be walking from Arandis railway station to the police station? (1)
 - (d) Give the location of the clinic in degrees, minutes and seconds. (2)
 - (e) What is the approximate height above sea level of the sewage disposal plant? (1)
 - (f) Calculate the length of the landing strip and give your answer in metres. Show your working. (3)
- [9]

QUESTION 2

Study the contour map below and answer the questions.

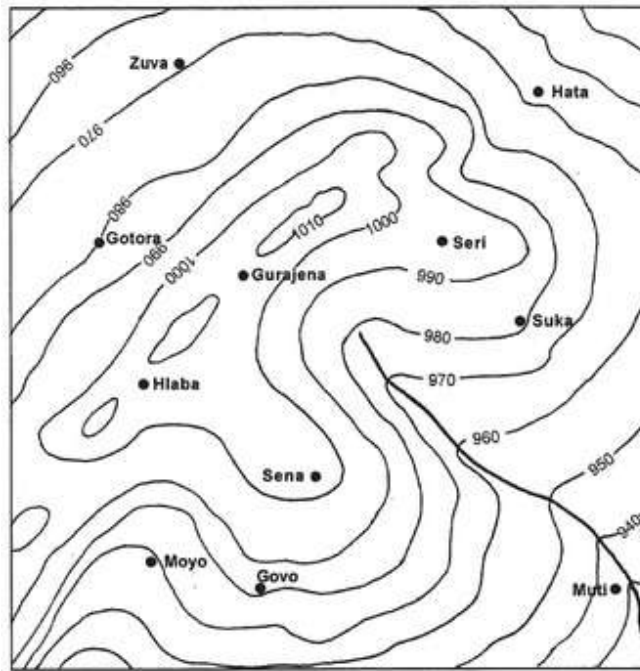

Figure 2

- (a) What is the vertical interval? (1)
- (b) Draw a spur with the broken line (---) on the contour map. (1)
- (c) In which direction does the river indicated with the solid line, flow? (1)
- (d) What type of landform will you find at Hlaba? (1)
- (e) Draw a cross section from Zuva to Moyo on the grid below.

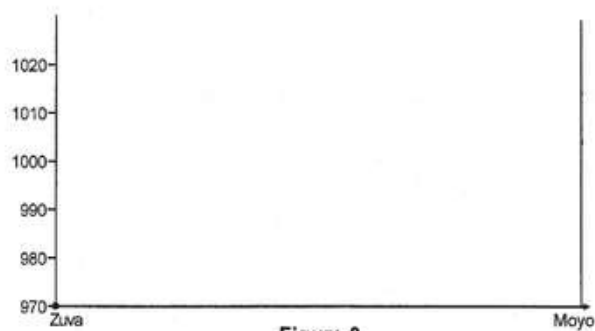

Figure 3

- (f) Will you be able to see Moyo from Zuva? (1)
- [10]

QUESTION 3

Study the diagram below, which shows the number of days the wind has blown for a specific month.

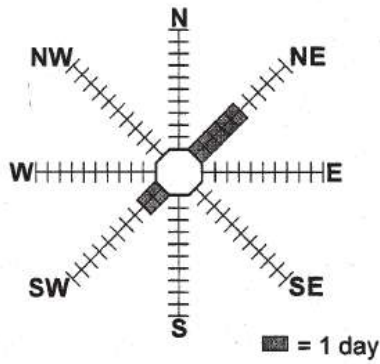

Figure 4

- (a) What name is given to this diagram? (1)
- (b) Complete the diagram by using the following information:
- NW : 7 days
- S : 4 days
- Calm : 12 days (3)
- [4]

QUESTION 4

- (a) Study the climate graph below and answer the following questions:

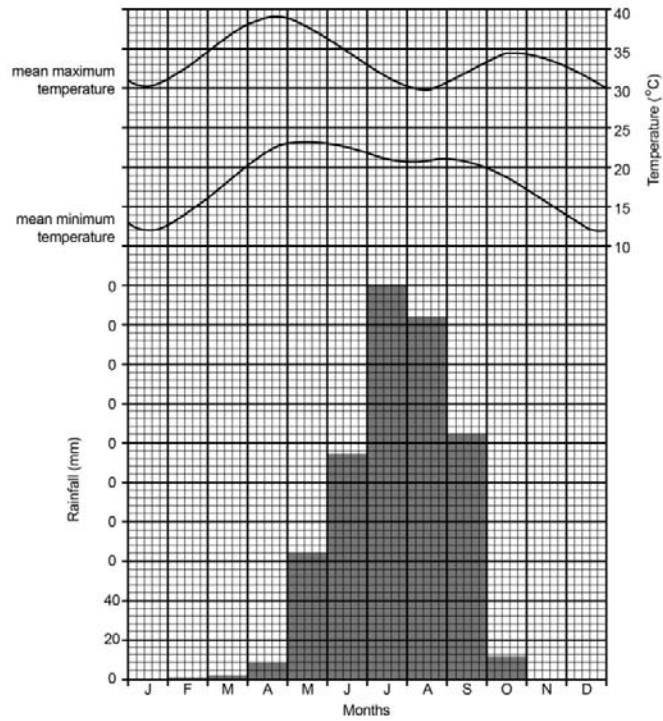

Figure 5

- (i) How much rain fell in July? (1)



- (ii) What was the highest temperature reached during the year? (1)
 - (iii) What was the average daily range of temperature in August? (1)
 - (iv) Why does the average temperature fall between May and August? (1)
 - (v) The rainfall for November was 32mm. Complete the bar for November. (1)
- (b) Complete the bar graph by using the table below.

Industries	% of workforce	Key for graph
Primary	11	
Secondary	22	
Tertiary	25	
Hi-Tech	42	

Figure 6

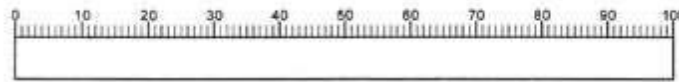

(3)

[8]

QUESTION 5

(a) Figure 7 below shows the changes in life expectancy between 1970 and 2002 in some countries in West Africa and South Asia.

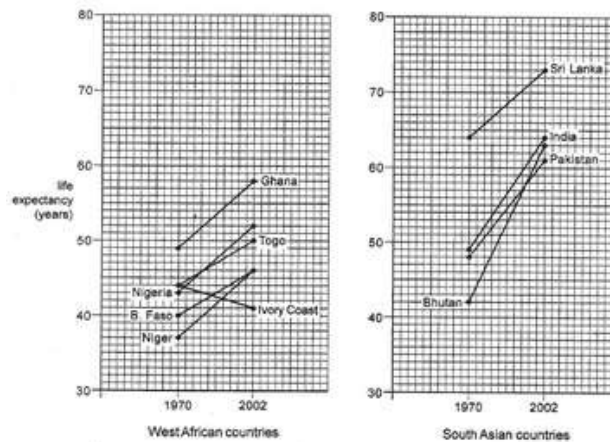

Figure 7

- (i) Which country had the highest life expectancy in 2002? (1)
- (ii) Which country showed a decrease in life expectancy between 1970 and 2002? (1)
- (iii) Life expectancy in Afghanistan in South Asia increased from 38 in 1970 to 43 in 2002. Plot this information on Figure 8. (1)
- (iv) Which country showed the greatest increase in life expectancy? (1)

(b) Study Figure 8 below, which shows orphans as a result of HIV and AIDS.

Orphans as a result of HIV/AIDS

(as a percentage of all children under 15 years)

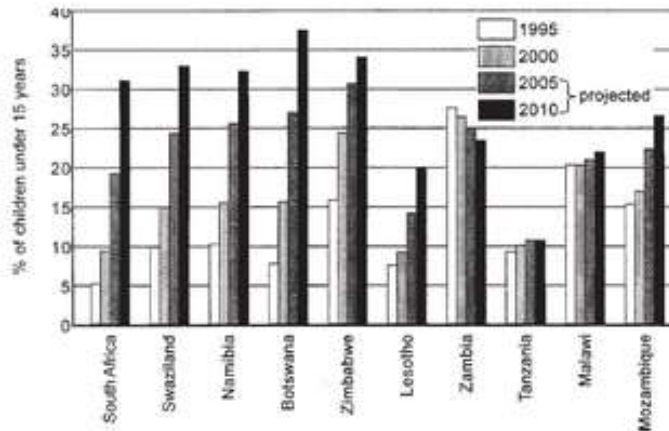

Figure 8

Use the information above to:

(i) State the percentage children who will be orphans as a result of HIV/AIDS in Lesotho in 2010. (1)

(ii) Name a country where the expected percentage orphans will be decreasing by 2010. (1)

[6]

QUESTION 6

Use the isoline map (figure 9) below and complete the following contour lines: 50, 60 and 80.

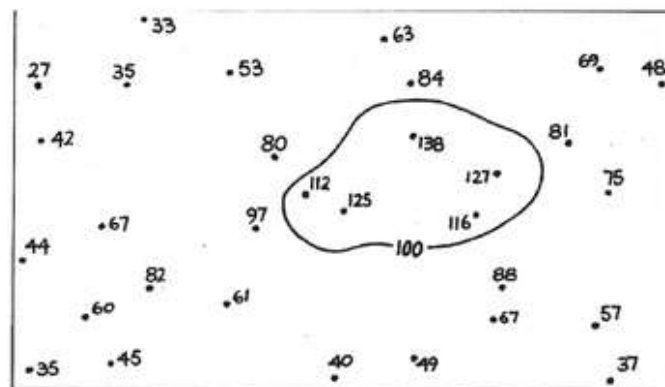

Figure 9

(3)

[3]

Total marks: 40



Answers to sample question papers



Assessment

Memorandum for Paper 1

QUESTION 1: CLIMATOLOGY

(a) (i) To store weather instruments in order to ensure protection of instruments against destruction by humans and animals and to ensure correct readings of correct data. (1)

(ii) (aa) To prevent direct sunlight from falling onto the instruments when the door is open. (1)

(bb) So that ground temperature will not have an influence on the instruments. (1)

(iii) (aa) Wind vane (1)

(bb) To record wind speed. (1)

/5/

(b) (i) Isobars (1)

(ii) High pressure (1)

(Hint: Air movement from inside to outside and the value of the isobars increase towards the centre.)

(iii) B – Low pressure

Also known as a cyclone. Air rotates clockwise from outside to inside while rising. Because warm, rising air is less dense, it can hold a lot of water vapour.

As it rises it will cool down and reach dew point temperature, condensation takes place, resulting in cloud formation. A low-pressure cell is therefore associated with the possibility of rain. (3)

/5/

(c) (i) Mountain breeze/catbatic (1)

(ii) During the night the ocean cools down more slowly than the land.

The temperature of the air above the ocean also remains warmer than the air above the land. The higher ocean temperatures lead to the forming of a low pressure system over the ocean, which causes the air to rise over the ocean.

Colder, denser air flows in from the land to the ocean – called a land breeze. (4)

/5/

[15]

QUESTION 2: ECOLOGY

- (a) (i) Ecology (1)
 (ii) Global warming (1)
 (iii) Desertification (1)
 (iv) Air pollution (1)
 (v) Bush encroachment (1)

/5/

- (b) (i) Land pollution (1)

(ii) People create unnecessary waste, especially for packaging.

We do not recycle the waste that we create.

Goods come in easily disposable containers, such as food, drinks and sweets.

Littering/dumping of waste. (any one) (1)

(iii) Empty tins/cans can be recycled.

Put garbage bins in all public places.

Heavy penalty fines should be given to people who litter.

Household waste like glass, cans, plastic and old vehicle oil can be taken to collection depots.

Some waste can be burned, but care must be taken not to pollute the air.

Refuse can be used to fill hollows in the land for building sites.

Public education and awareness campaigns should be organised like advertising, pamphlets, posters and other materials. (Any 3)

(3)

/5/

(c) (i) Bush encroachment is when open savanna (grassy) areas become covered with dense, woody plants. (1)

(ii) Human causes

~ Poor farming management like over-stocking.

~ When bush fires do not occur or are prevented.

~ Clearing of land for cultivation.

Natural causes

~ Severe droughts.

~ Periodic floods.

~ Seeds in kudu dung are spread over large areas. (2)

(iii) Farming with boer goats – they not only browse on the leaves, but debark the stems and branches.



Controlled fires.

Clear land using bulldozers and chain saws.

Treat invader bushes with chemicals such as herbicides.

Train farmers to use the correct management practices. (2)

/5/

[15]

QUESTION 3: GEOMORPHOLOGY

(a) (i) A piece of crust of the earth with a continent or an ocean, or both, on it. (1)

(ii) (aa) Diverging plate boundary

(bb) Converging plate boundary (2)

(iii) Mid-Atlantic Ridge (1)

(iv) When an ocean plate meets a continental plate, or where two ocean plates meet, the denser plate will be forced to bend downwards and sink into the mantle – called a subduction zone. (1)

/5/

(b) (i) An earthquake is the physical evidence on the earth's surface of the movement of the plates below the surface. (1)

(ii) A (1)

(iii) (aa) Tsunamis are caused by undersea earthquakes.

Shock waves release enormous amounts of energy that travel through the water in the form of waves at speeds of up to 800 km per hour.

(1)

(bb) Destruction of everything in the path of the tsunami – 250 000 people were killed and millions left homeless. (2)

/5/

(c) (i) Weathering is the breaking up of sediments (rocks and sand) on the surface of the earth as they are exposed to the elements such as temperature, rainfall and wind. (1)

(ii) Wind

Water

Ice

Waves

(2)

(iii) In cold, wet regions water fills the cracks in a rock. At night the water freezes and expands. During the day the water melts and runs deeper into the crack.

This constant freezing and melting deepen and widen cracks.

	(2)
	/5/
	[15]
QUESTION 4:	
POPULATION GEOGRAPHY	
(a) (i) Population density is the number of people per km ² .	(1)
(ii) Oshana	
Over 30 people per km ²	(2)
(iii) Sparsely means widely spread or scattered.	(1)
Few people per km ²	
(iv) Dry area of the country – large areas are needed for farming to support very few people.	
Poor soil fertility.	(1)
	/5/
(b) (i) 8.2 billion	(1)
(ii) South Asia	(1)
(iii) 4.1 billion	(1)
(iv) Food shortage	
Housing problems	(2)
Unemployment	
Lack of services	
	/5/
(c) (i) AIDS – Acquired immune deficiency syndrome	(1)
(ii) 25 – 29 years of age	(1)
(iii) From 4% to 22% – that is 18%	(1)
(iv) Awareness campaigns	
Social networks/services	
ARVS	(2)
	/5/
	[15]
QUESTION 5	
(a) (i) Areas of self-built houses	
Open drains	
Scattered shops	
Close to industrial area (any 2)	(2)



- (ii) Shops, schools and businesses close
 Only old people and young children stay behind
 Breaking up of families
 Not enough workers to work on the land
 Rural depopulation (3)
 /5/
- (b) (i) Fertility refers to the number of young children in relation to the number of women of fertile age in the population. It therefore refers to the births in a country or population. (1)
- (ii) Mortality rate refers to the number of people per thousand who die each year. A high infant mortality rate will have an effect on the birth rate. The birth rate will increase because people need more children in the hope that some will survive. (2)
- (iii) Conditions like medical care – diet
 Diseases
 No good pension or old age homes
 Working conditions are different in developing countries
 Unemployment
 Poor living conditions
 Lack of clean water (2)
 /5/
 [10]
- QUESTION 6:**
REGIONAL GEOGRAPHY
- (a) (i) Angola (1)
 (ii) Central Plateau (1)
 (iii) Fish River (1)
 (iv) Fish River Canyon (1)
 (v) The waterfall (1)
 /5/
- (b) (i) A Trawling
 B Purse seine fishing (2)
- (ii) B Purse seine fishing
 (Fish that live near the surface of the ocean) (1)
- (iii) Fish is exported in many forms: frozen, tinned and fresh, and this creates valuable foreign exchange and income for the country.
 Foreign ships must pay to get a fishing permit/licence. The ports of Walvis Bay and Luderitz are also a source of income because ships

anchor in the harbours.

It provides jobs

It is a source of food (2)

/5/

[10]

QUESTION 7

(a) (i) A Trans Caprivi Highway

B Trans Kalahari Highway (2)

(ii) Botswana, Zambia, Zimbabwe (Any 2) (2)

(iii) Railroad

(aa) Cheap way of transport within the borders of Namibia.

Luxury train between Windhoek and Swakopmund called the Desert Express

(bb) No railroads that are linked to neighbouring countries.

Slow means of transport and it will take time for goods to reach their destination.

Sea

(aa) Cheap to transport large quantities of goods.

(bb) Very slow and only two harbours.

Air

(aa) Fast to transport valuable goods.

(bb) Very expensive. (2)

/6/

(b) (i) Rundu (1)

(ii) More humid in the northern parts of Namibia.

Latitude – Rundu closer to the equator. (1)

(iii) Walvis Bay (1)

(iv) Coastal places have an oceanic or maritime climate (small range in temperature)

Walvis Bay – situated close to the sea. (1)

/4/

[10]

PAPER 2

QUESTION 1

- (a) Ratio scale (1)
- (b) One centimeter on the map represents fifty thousand centimeters in reality or on the ground. (1)
- (c) North west (1)
- (d) $22^{\circ} 44' 30''$ S; $14^{\circ} 58' 59''$ E (2)
- (e) Less than 541 m above sea level, approximately 500 m. (1)
- (f) $3.4 \text{ cm} \times 50\,000 \div 100\,000$
 $= 170\,000 \div 100\,000$
 $= 1,7 \text{ km}$
 To convert it to meter
 $= 1,7 \text{ km} \times 1\,000$
 $= 1\,700 \text{ meter}$ (3)
- [9]

QUESTION 2

- (a) The difference in height between two contour lines are called contour/vertical interval. The vertical interval is 10 m. (1)
- (b) On the map (1)

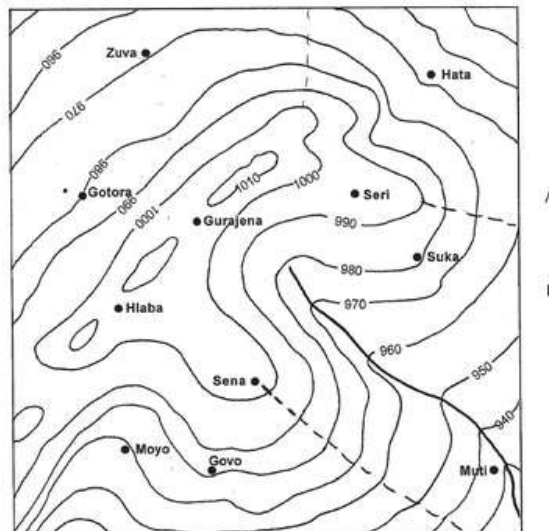
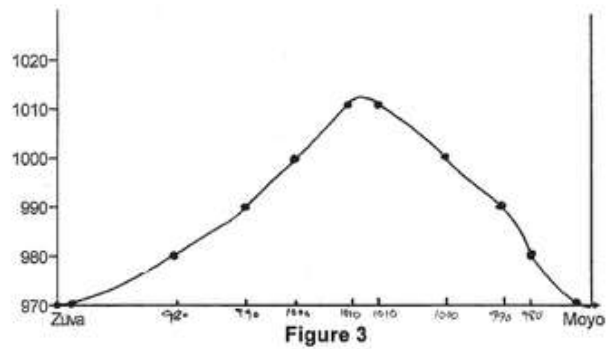

Figure 2

- (c) South east (1)

- (d) Saddle (1)
 (e) On the map (5)



- (f) No (1)
 [10]

QUESTION 3

- (a) Wind rose (1)
 (b) On the diagram (3)

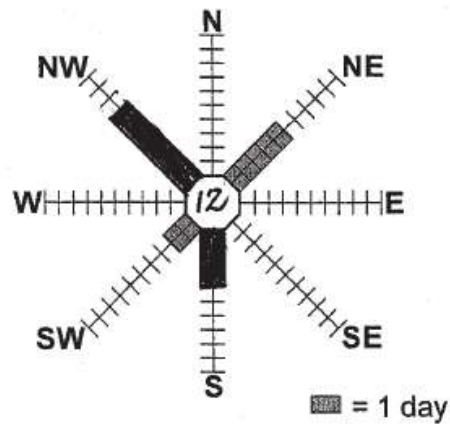

Figure 4 [4]

QUESTION 4

- (a) (i) 200 mm (1)
 (ii) 39.5 °C (1)
 (iii) 30 °C - 21 °C = 9 °C (1)
 (iv) Winter in Southern Hemisphere (1)
 (v) On the map (1)

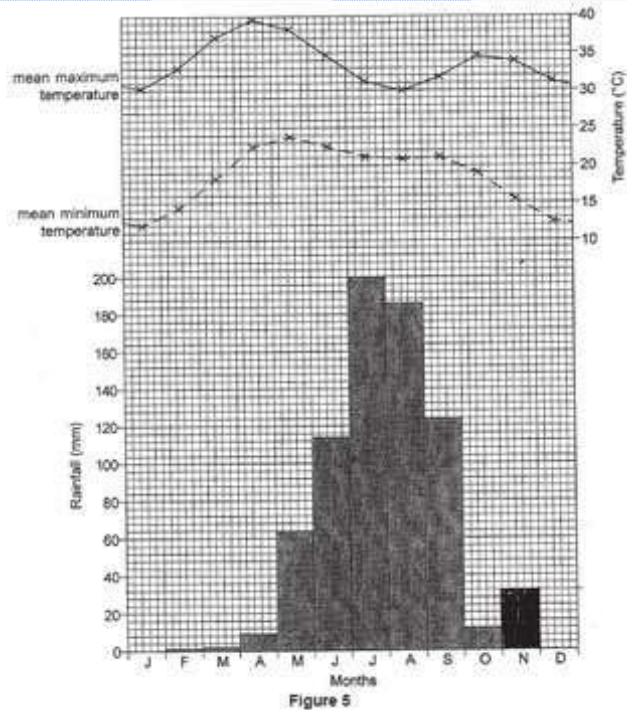

Figure 5

(b) Graph



(3)

[8]

QUESTION 5

- (a) (i) Sri Lanka (1)
- (ii) Ivory Coast (1)
- (iii) On the Map (1)

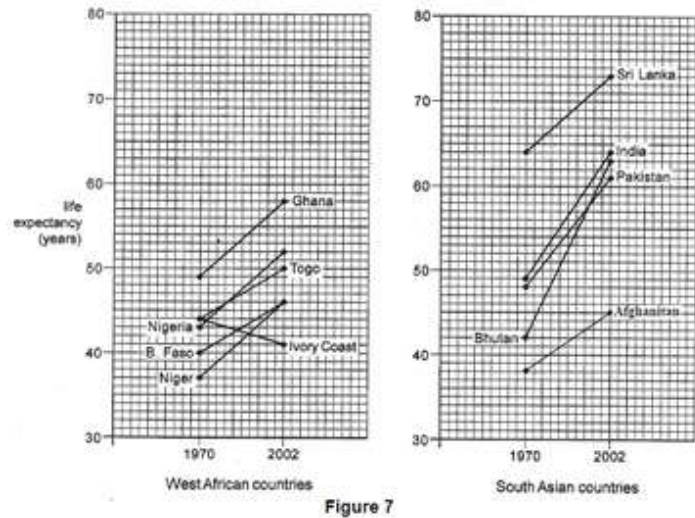

Figure 7

Figure 7

- (iv) Bhutan (1)
 - (b) (i) 20 % (1)
 - (ii) Zambia (1)
- [6]

QUESTION 6

Isolines drawn on the map (3)

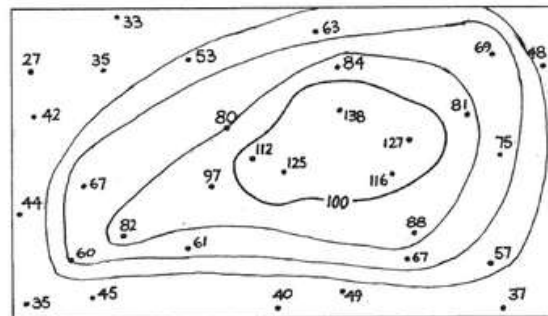

Figure 9

[3]

TOTAL MARKS: 40